

## How to use this manual

---

# A Few Words About Safety

## SERVICE INFORMATION

The service and repair information contained in this manual is intended for use by qualified, professional technicians. Attempting service or repairs without the proper training, tools, and equipment could cause injury to you and/or others. It could also damage this Honda product or create an unsafe condition.

This manual describes the proper methods and procedures for performing service, maintenance, and repairs. Some procedures require the use of special tools. Any person who intends to use a replacement part, service procedure or a tool that is not recommended by Honda, must determine the risks to their personal safety and the safe operation of this product.

If you need to replace a part, use Honda Genuine parts with the correct part number or an equivalent part. We strongly recommend that you do not use replacement parts of inferior quality.

## For Your Customer's Safety

Proper service and maintenance are essential to the customer's safety and the reliability of this product. Any error or oversight while servicing this product can result in faulty operation, damage to the product, or injury to others.

### **⚠ WARNING**

Improper service or repairs can create an unsafe condition that can cause your customer or others to be seriously hurt or killed.

Follow the procedures and precautions in this manual and other service materials carefully.

## For Your Safety

Because this manual is intended for the professional service technician, we do not provide warnings about many basic shop safety practices (e.g., Hot parts-wear gloves). If you have not received shop safety training or do not feel confident about your knowledge of safe servicing practice, we recommend that you do not attempt to perform the procedures described in this manual.

Some of the most important general service safety precautions are given below. However, we cannot warn you of every conceivable hazard that can arise in performing service and repair procedures. Only you can decide whether or not you should perform a given task.

### **⚠ WARNING**

Failure to properly follow instructions and precautions can cause you to be seriously hurt or killed.

Follow the procedures and precautions in this manual carefully.

## Important Safety Precautions

Make sure you have a clear understanding of all basic shop safety practices and that you are wearing appropriate clothing and using safety equipment. When performing any service task, be especially careful of the following:

- Read all of the instructions before you begin, and make sure you have the tools, the replacement or repair parts, and the skills required to perform the tasks safely and completely.
- Protect your eyes by using proper safety glasses, goggles, or face shields anytime you hammer, drill, grind, or work around pressurized air, pressurized liquids, springs or other stored-energy components. If there is any doubt, put on eye protection.
- Use other protective wear when necessary, for example gloves or safety shoes. Handling hot or sharp parts can cause severe burns or cuts. Before you grab something that looks like it can hurt you, stop and put on gloves.
- Protect yourself and others whenever you have engine-power equipment up in the air. Anytime you lift this product with a hoist, make sure that the hoist hook is securely attached to the product.

Make sure the engine is off before you begin any servicing procedures, unless the instruction tells you to do otherwise. This will help eliminate several potential hazards:

- Carbon monoxide poisoning from engine exhaust. Be sure there is adequate ventilation whenever you run the engine.
- Burns from hot parts. Let the engine and exhaust system cool before working in those areas.
- Injury from moving parts. If the instruction tells you to run the engine, be sure your hands, fingers and clothing are out of the way.

Gasoline vapors and hydrogen gasses from battery are explosive. To reduce the possibility of a fire or explosion, be careful when working around gasoline or batteries.

- Use only a nonflammable solvent, not gasoline, to clean parts.
  - Never store gasoline in an open container.
  - Keep all cigarettes, sparks, and flames away from the battery and all fuel-related parts.
-

---

## CONTENTS

<b>SPECIFICATIONS</b>	<b>1</b>
<b>SERVICE INFORMATION</b>	<b>2</b>
<b>MAINTENANCE</b>	<b>3</b>
<b>TROUBLESHOOTING</b>	<b>4</b>
<b>COVER</b>	<b>5</b>
<b>FUEL SYSTEM</b>	<b>6</b>
<b>CHARGING SYSTEM</b>	<b>7</b>
<b>IGNITION SYSTEM</b>	<b>8</b>
<b>STARTING SYSTEM</b>	<b>9</b>
<b>OTHER ELECTRICAL</b>	<b>10</b>
<b>MUFFLER</b>	<b>11</b>
<b>LUBRICATION SYSTEM</b>	<b>12</b>
<b>CYLINDER</b>	<b>13</b>
<b>CRANKCASE</b>	<b>14</b>
<b>TECHNICAL FEATURES</b>	<b>15</b>
<b>WIRING DIAGRAMS</b>	<b>16</b>
<b>INDEX</b>	

## How to use this manual

---

# INTRODUCTION

This manual covers the service and repair procedures for the Honda GX700IRH·GX800IRH.

All information contained in this manual is based on the latest product information available at the time of printing. We reserve the right to make changes at anytime without notice.

No part of this publication may be reproduced, stored in a retrieval system, or transmitted, in any form, by any means, electronic, mechanical, photocopying, recording, or otherwise, without prior written permission of the publisher. This includes text, figures, and tables.

As you read this manual, you will find information that is preceded by a **NOTICE** symbol. The purpose of this message is to help prevent damage to this Honda product, other property, or the environment.

## SAFETY MESSAGES

Your safety and the safety of others are very important. To help you make informed decisions, we have provided safety messages and other safety information throughout this manual. Of course, it is not practical or possible to warn you about all the hazards associated with servicing these products. You must use your own good judgment.

You will find important safety information in a variety of forms, including:

- Safety Labels – on the product.
- Safety Messages – preceded by a safety alert symbol  and one of three signal words, DANGER, WARNING, or CAUTION. These signal words mean:

** DANGER** You WILL be KILLED or SERIOUSLY HURT if you don't follow instructions.

** WARNING** You CAN be KILLED or SERIOUSLY HURT if you don't follow instructions.

** CAUTION** You CAN be HURT if you don't follow instructions.

- Instructions – how to service these products correctly and safely.

ALL INFORMATION, ILLUSTRATIONS, DIRECTIONS AND SPECIFICATIONS INCLUDED IN THIS PUBLICATION ARE BASED ON THE LATEST PRODUCT INFORMATION AVAILABLE AT THE TIME OF APPROVAL FOR PRINTING. Honda Motor Co., Ltd. RESERVES THE RIGHT TO MAKE CHANGES AT ANY TIME WITHOUT NOTICE AND WITHOUT INCURRING ANY OBLIGATION WHATSOEVER. NO PART OF THIS PUBLICATION MAY BE REPRODUCED WITHOUT WRITTEN PERMISSION. THIS MANUAL IS WRITTEN FOR PERSONS WHO HAVE ACQUIRED BASIC KNOWLEDGE OF MAINTENANCE ON Honda PRODUCTS.





## SERVICE RULES

- Use Honda Genuine or Honda-recommended parts and lubricants or their equivalents. Parts that do not meet Honda's design specifications may damage the unit.
- Use the special tools designed for the product.
- Install new gaskets, O-rings, etc. when reassembling.
- When torquing bolts or nuts, begin with larger-diameter or inner bolts first and tighten to the specified torque diagonally, unless a particular sequence is specified.
- Clean parts in cleaning solvent upon disassembly. Lubricate any sliding surfaces before reassembly.
- After reassembly, check all parts for proper installation and operation.
- Many screws used in this machine are self-tapping. Be aware that cross-threading or overtightening these screws will strip the threads and ruin the hole.

Use only metric tools when servicing this unit. Metric bolts, nuts and screws are not interchangeable with non-metric fasteners. The use of incorrect tools and fasteners will damage the unit.

## SYMBOLS

The symbols used throughout this manual show specific service procedures. If supplementary information is required pertaining to these symbols, it would be explained specifically in the text without the use of the symbols.

	Replace the part(s) with new one(s) before assembly.
	Use the recommend engine oil, unless otherwise specified.
	Use molybdenum oil solution (mixture of the engine oil and molybdenum grease in a ratio of 1:1).
	Use multi-purpose grease (lithium based multi-purpose grease NLGI #2 or equivalent).
	Apply sealant.
(O x O) (O)	Indicates the diameter, length, and quantity of metric bolts used.
page 1-1	Indicates the reference page.

## How to use this manual

---

# ABBREVIATIONS

Throughout this manual, the following abbreviations are used to identify the respective parts or systems

Abbrev. term	Full term
ACG	Alternator
API	American Petroleum institute
Approx.	Approximately
Assy.	Assembly
ATDC	After Top Dead Center
ATF	Automatic Transmission Fluid
ATT	Attachment
BAT	Battery
BDC	Bottom Dead Center
BTDC	Before Top Dead Center
BARO	Barometric Pressure
CKP	Crankshaft Position
Comp.	Complete
CMP	Camshaft Position
CYL	Cylinder
DLC	Data Link Connector
EBT	Engine Block Temperature
ECT	Engine Coolant Temperature
ECU	Engine Control Unit
EMT	Exhaust Manifold Temperature
EOP	Engine Oil Pressure
EX	Exhaust
F	Front or Forward
GND	Ground
HO2S	Heated Oxygen sensor
IAC	Idle Air Control
IAT	Intake Air Temperature
I.D.	Inside diameter
IG or IGN	Ignition
IN	Intake
INJ	Injection
L.	Left
MAP	Manifold Absolute Pressure
MIL	Malfunction Indicator Lamp
O.D.	Outside Diameter
OP	Optional Part
PGM-FI	Programmed-Fuel Injection
P/N	Part Number
Qty	Quantity
R.	Right
SAE	Society of Automotive Engineers
SCS	Service Check Signal
STD	Standard
SW	Switch
TDC	Top Dead Center
TE	Temperature of Engine
TP	Throttle Position
VTEC	Variable Valve Timing & Valve Lift Electronic Control

Bl	Black	G	Green	Br	Brown	Lg	Light green
Y	Yellow	R	Red	O	Orange	P	Pink
Bu	Blue	W	White	Lb	Light blue	Gr	Gray

---

SERIAL NUMBER LOCATION .....	1-2	DIMENSIONAL DRAWINGS .....	1-6
DIMENSIONS AND WEIGHTS SPECIFICATIONS .....	1-2	P.T.O. DIMENSIONAL DRAWINGS .....	1-8
ENGINE SPECIFICATIONS .....	1-3	ENGINE MOUNT DIMENSIONAL DRAWING .....	1-10
PERFORMANCE CURVES .....	1-4		

## SPECIFICATIONS

### SERIAL NUMBER LOCATION

The engine serial number [1] is stamped on the crankcase.

Refer to it when ordering parts or making technical inquiries.

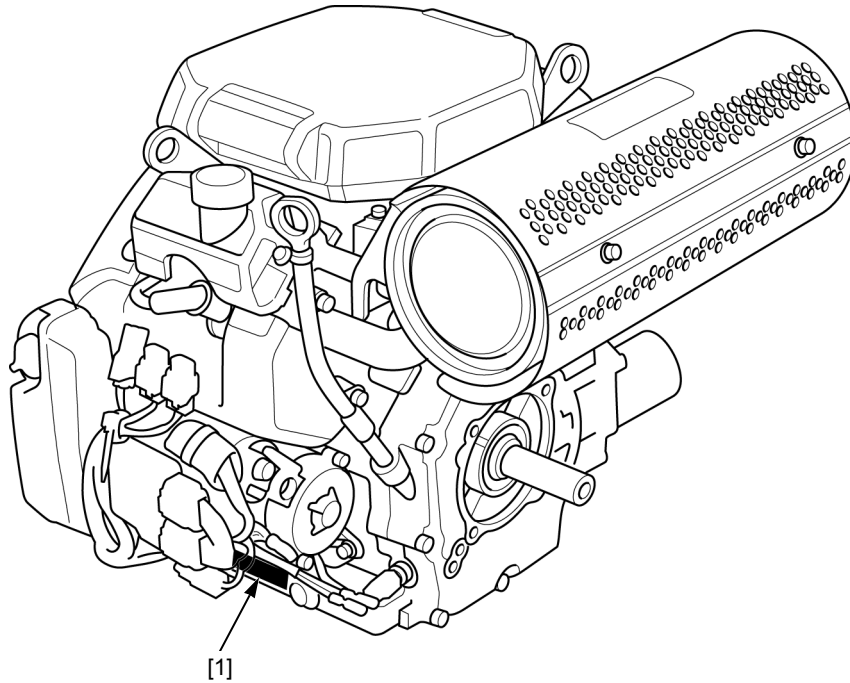

### DIMENSIONS AND WEIGHTS SPECIFICATIONS

Model	GX700IRH	GX800IRH
Overall length	T type: 429 mm (16.9 in) B type: 442 mm (17.4 in) V type: 426 mm (16.8 in) IS 9T type: 365 mm (14.4 in) IS 13T type: 365 mm (14.4 in)	T type: 429 mm (16.9 in) B type: 442 mm (17.4 in) V type: 426 mm (16.8 in)
Overall width	483 mm (19.0 in)	492 mm (19.4 in)
Overall height	438 mm (17.2 in)	
Dry weight	T type: 47.1 kg (103.8 lbs) B type: 47.5 kg (104.7 lbs) V type: 47.1 kg (103.8 lbs) IS 9T type: 46.8 kg (103.2 lbs) IS 13T type: 46.9 kg (103.4 lbs)	T type: 46.9 kg (103.4 lbs) B type: 47.3 kg (104.3 lbs) V type: 46.9 kg (103.4 lbs)
Operating weight	T type: 48.7 kg (107.4 lbs) B type: 49.1 kg (108.2 lbs) V type: 48.7 kg (107.4 lbs) IS 9T type: 48.4 kg (106.7 lbs) IS 13T type: 48.5 kg (106.9 lbs)	T type: 48.5 kg (106.9 lbs) B type: 48.9 kg (107.8 lbs) V type: 48.5 kg (106.9 lbs)
Maximum angle of inclination	Forward and backward: 20° Left and right: 20°	

### EQUIPMENT VARIATION

Model	GX700IRH	GX800IRH
Variation	Without control box type	
Overall length difference	-	
Overall width difference	-	
Overall height difference	-	
Dry weight difference	- 1.0 kg (2.2 lbs)	
Operating weight difference	- 1.0 kg (2.2 lbs)	

**ENGINE SPECIFICATIONS**

Model	GX700IRH	GX800IRH
Description code	GCAUH	GCAVH
Type	4 stroke, overhead valve, 90° V-twin cylinder	
Displacement	688.0 cm <sup>3</sup> (41.97 cu-in)	779.0 cm <sup>3</sup> (47.52 cu-in)
Bore x stroke	78.0 x 72.0 mm (3.07 x 2.83 in)	83.0 x 72.0 mm (3.27 x 2.83 in)
Net power (SAE J1349)*	16.5 kW (22.1 HP)/3,600 rpm	18.6 kW (24.9 HP)/3,600 rpm
Continuous rated power	13.0 kW (17.4 HP)/3,600 rpm	15.0 kW (20.1 HP)/3,600 rpm
Maximum net torque (SAE J1349)*	48.3 N·m (4.93 kgf·m, 35.6 lbf·ft)/ 2,500 rpm	54.5 N·m (5.56 kgf·m, 40.2 lbf·ft)/ 2,500 rpm
Maximum rpm (at no load)	3,600 ± 150 rpm	3,600 ± 150 rpm
Compression ratio	9.3	9.1
Fuel consumption (at continuous rated power)	6.6 Liters (1.74 US gal, 1.45 Imp gal)/h	7.1 Liters (1.88 US gal, 1.56 Imp gal)/h
Ignition system	Full transistorized, battery ignition	
Ignition timing	A.T.D.C. 3°/1,400 rpm	B.T.D.C. 3°/1,400 rpm
Spark advancer type	Electronic type	
Spark advancer performance	#1: A.T.D.C. 3° – B.T.D.C. 17° #2: A.T.D.C. 3° – B.T.D.C. 23°	#1: B.T.D.C. 3° – 19.5° #2: B.T.D.C. 3° – 24°
Spark plug	BPR5ES (NGK)	
Lubrication system	Forced feed	
Oil capacity	Without oil filter replacement: 1.5 Liters (1.59 US qt, 1.32 Imp qt) With oil filter replacement: 1.7 Liters (1.80 US qt, 1.50 Imp qt)	Without oil filter replacement: 1.6 Liters (1.70 US qt, 1.41 Imp qt) With oil filter replacement: 1.8 Liters (1.90 US qt, 1.58 Imp qt)
Recommended oil	SAE 5W-30 or 10W-30 API service classification SJ or later	
Cooling system	Forced air	
Starting system	Starter motor	
Stopping system	Ignition primary circuit open	
Air cleaner	Dual type	
Governor	Electric system (Self Tuning Regulator)	
Breather system	Reed valve type, PCV (Positive Crankcase Ventilation) type	
Fuel used	Unleaded gasoline E10	

\*: The power rating of the engine indicated in this document is the net power output tested on a production engine for the engine model and measured in accordance with SAE J1349 at 3,600 rpm (net power) and at 2,500 rpm (max net torque). Mass production engines may vary from this value. Actual power output for the engine installed in the final machine will vary depending on numerous factors, including the operating speed of the engine in application, environmental conditions, maintenance, and other variables.



SPECIFICATIONS

PERFORMANCE CURVES

GX700IRH

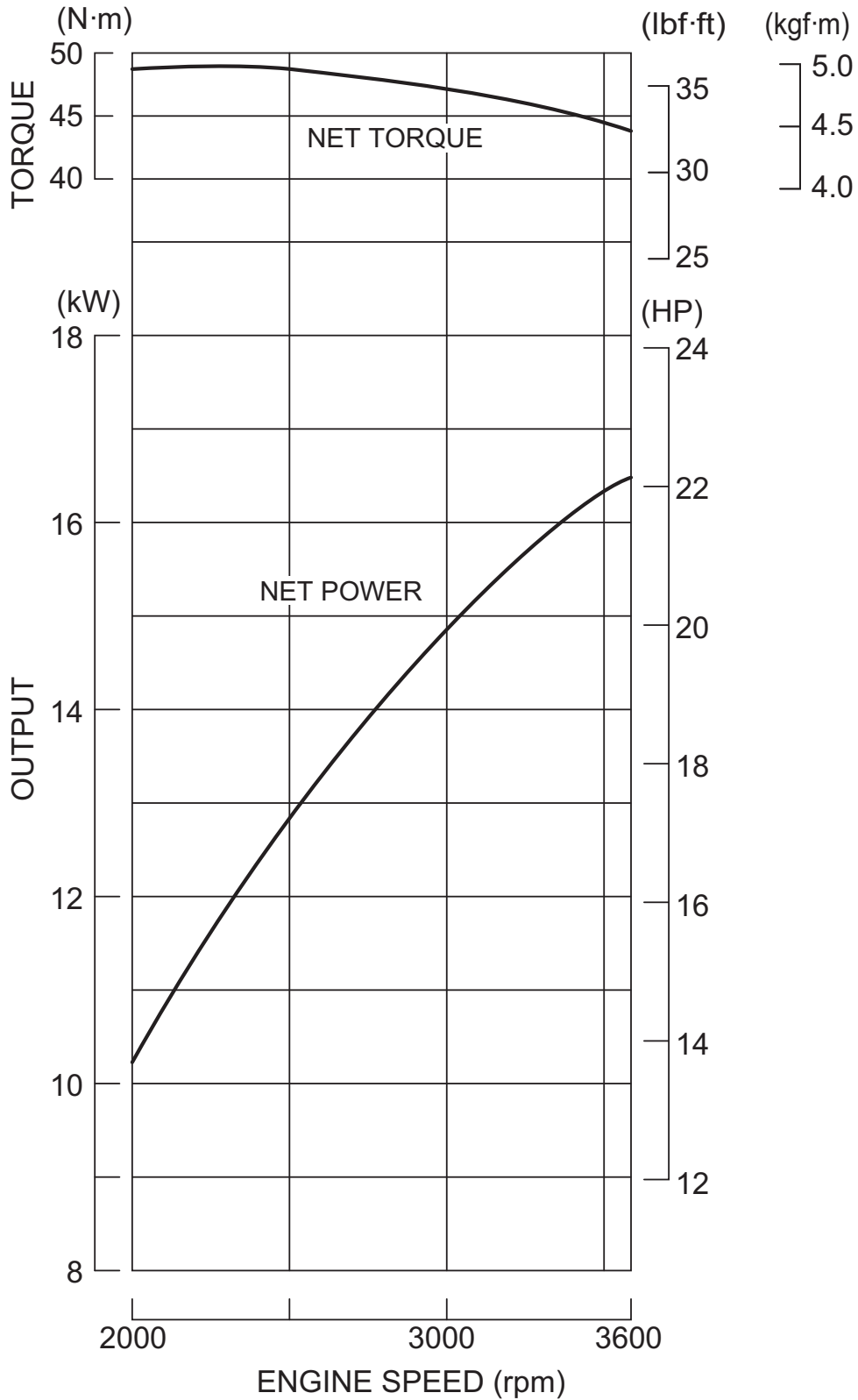

GX800IRH

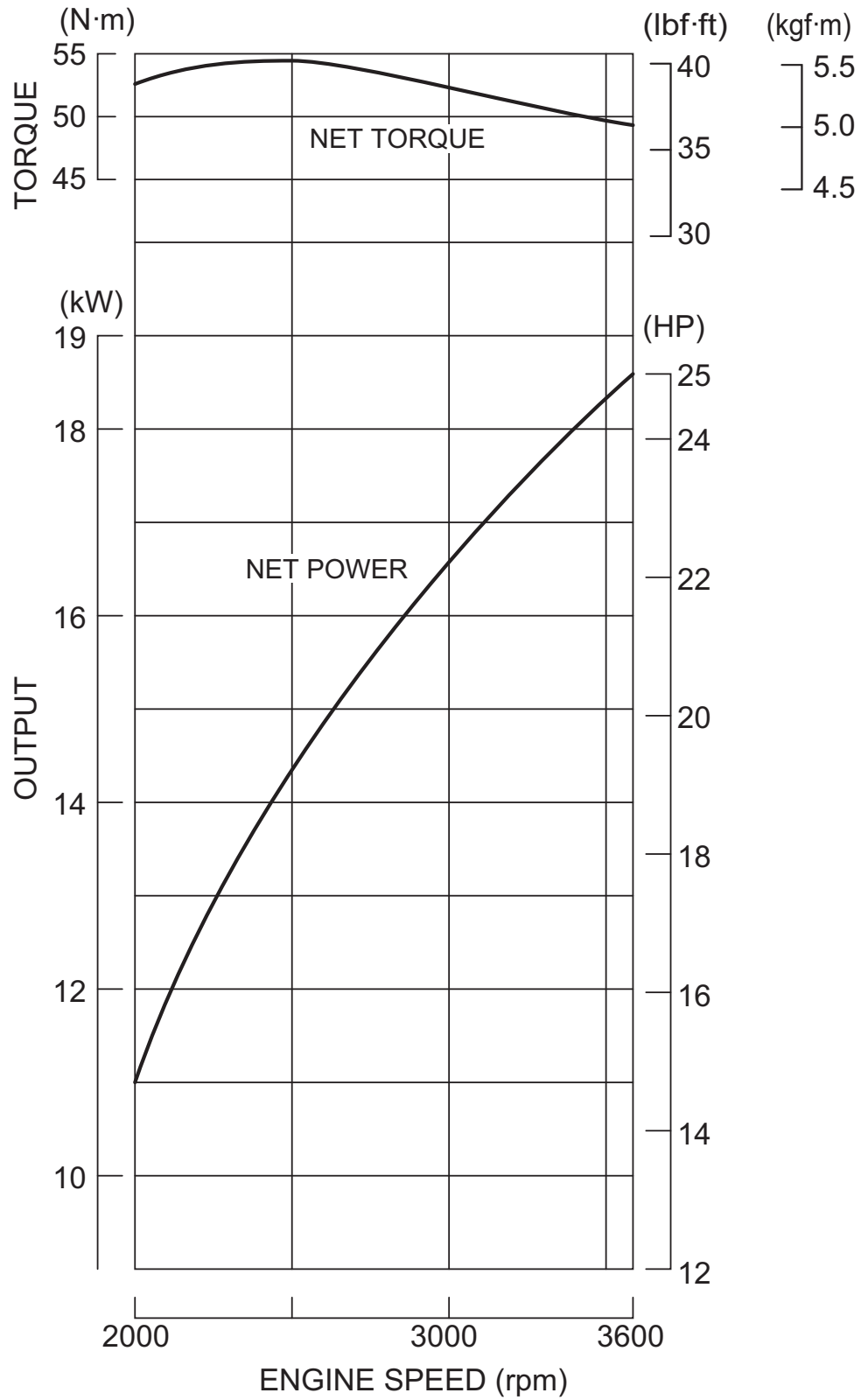

# SPECIFICATIONS

## DIMENSIONAL DRAWINGS

GX700IRH

Unit: mm (in)

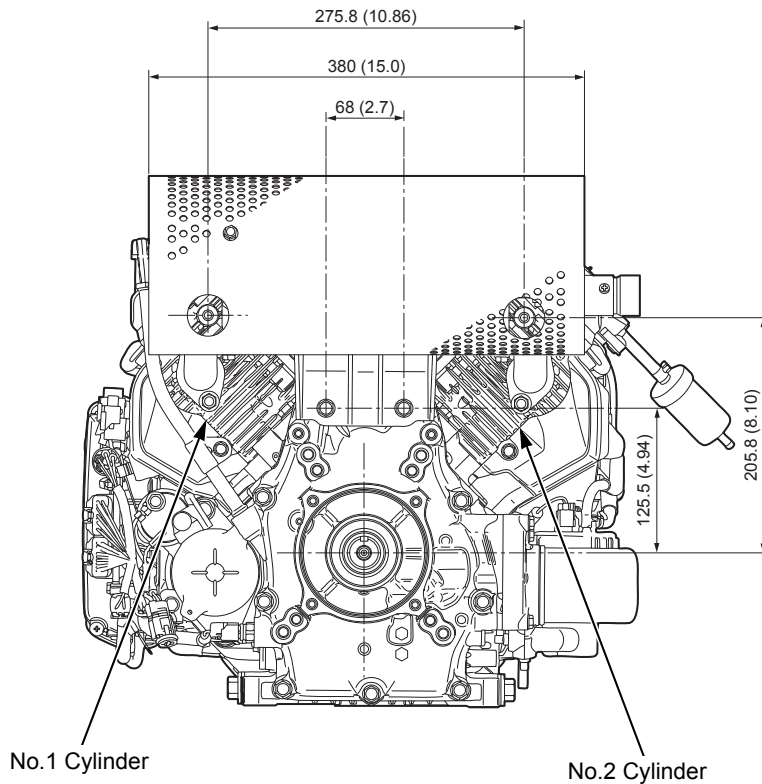
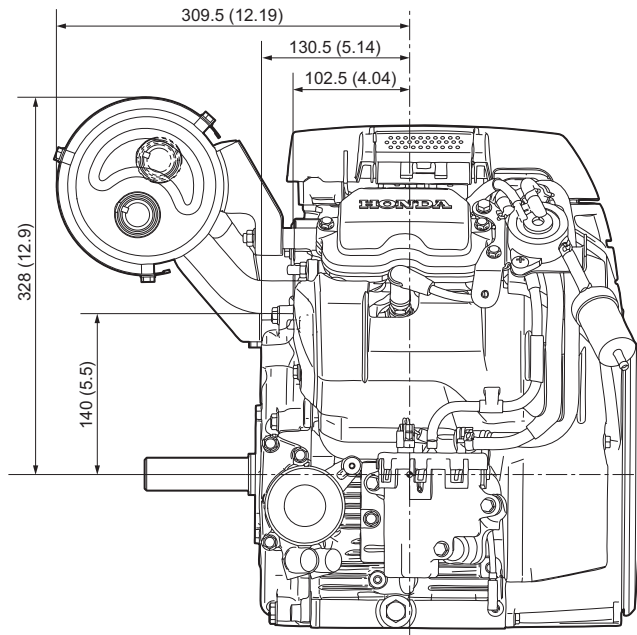
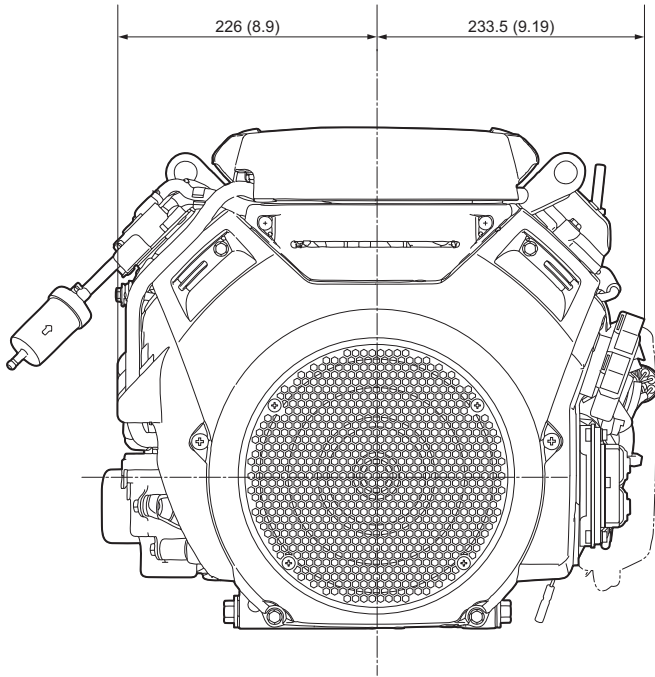

**GX800IRH**

Unit: mm (in)

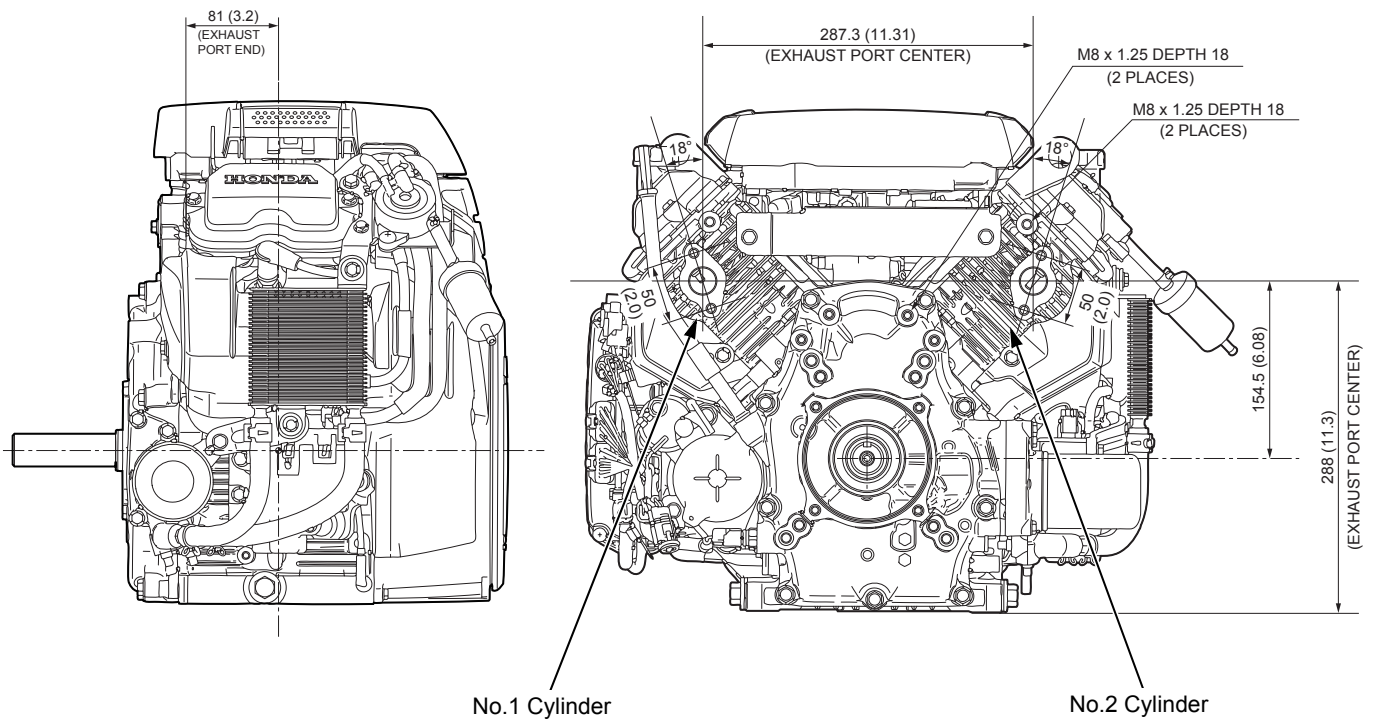
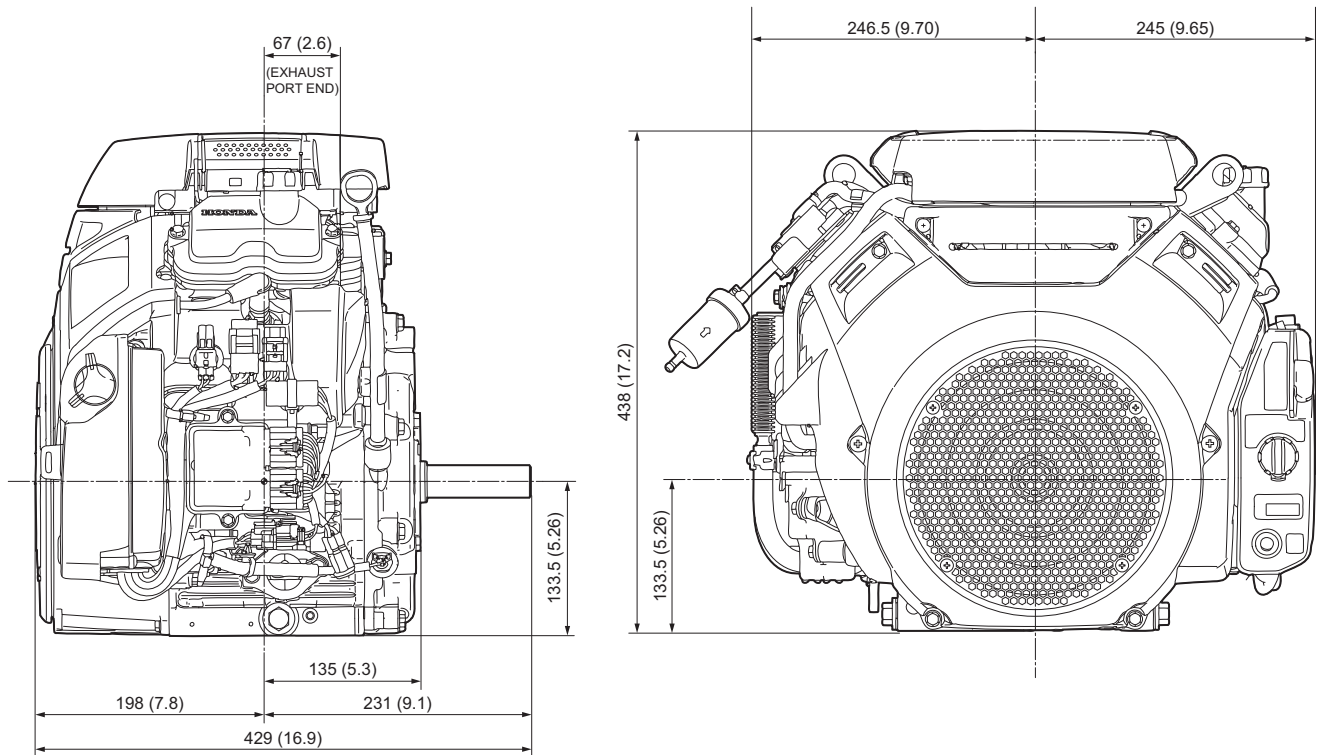

**SPECIFICATIONS**

**P.T.O. DIMENSIONAL DRAWINGS**

**T TYPE**

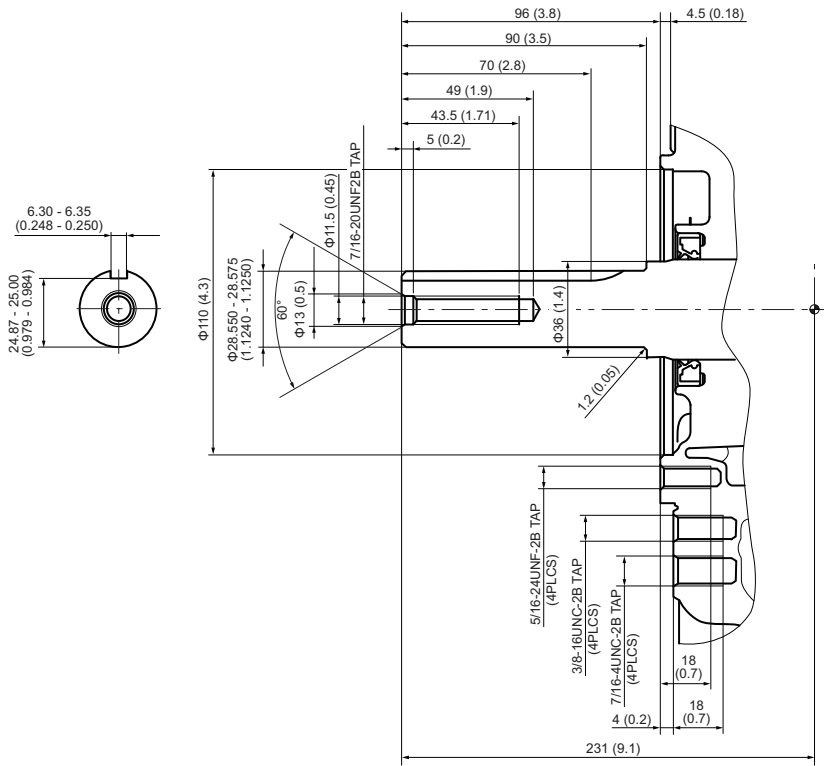

Unit: mm (in)

**B TYPE**

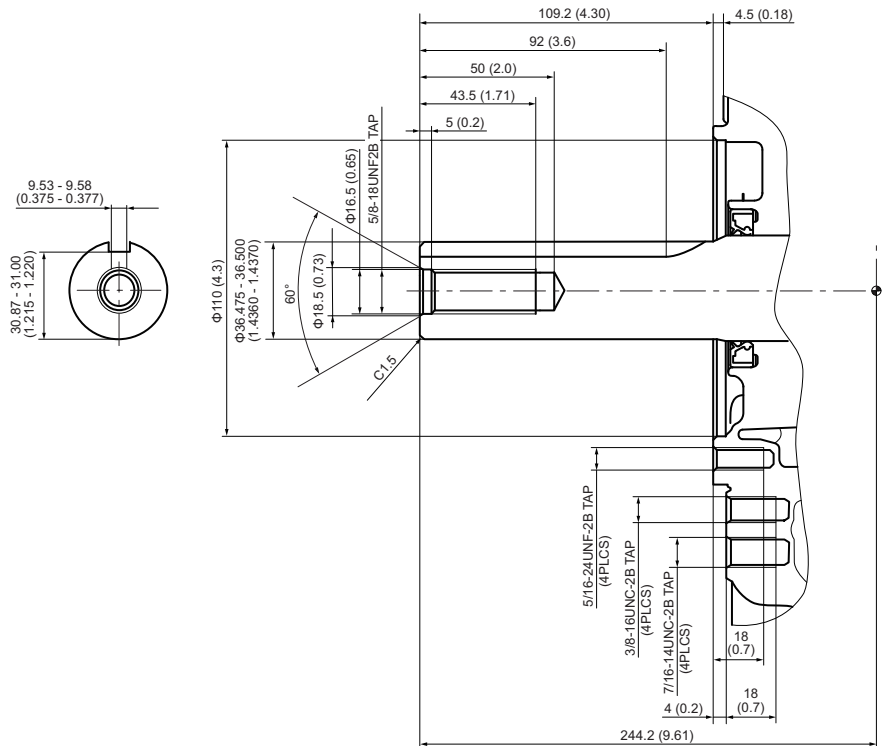

Unit: mm (in)

**V TYPE**

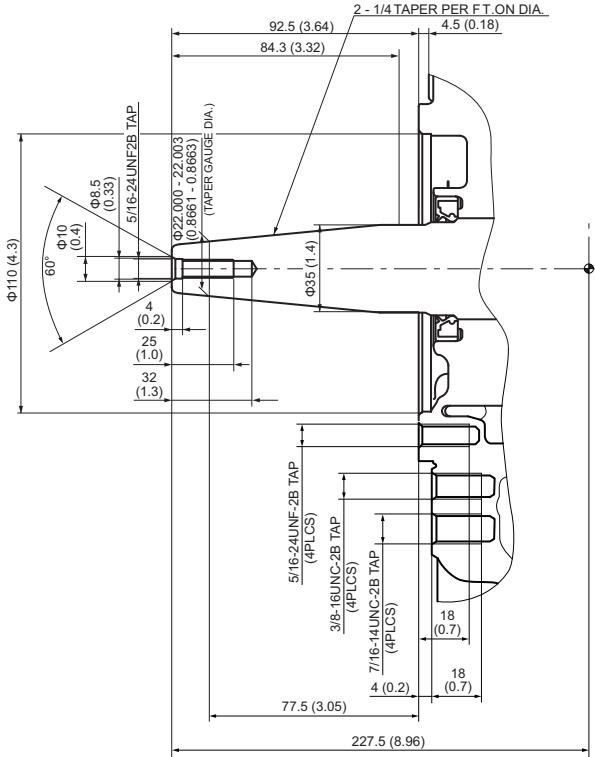

**IS 9T TYPE**

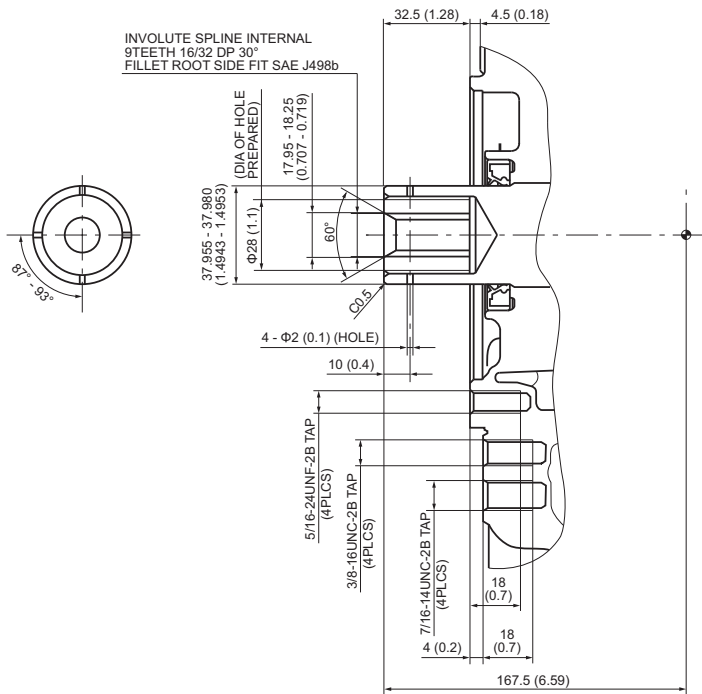

# SPECIFICATIONS

## IS 13T TYPE

Unit: mm (in)

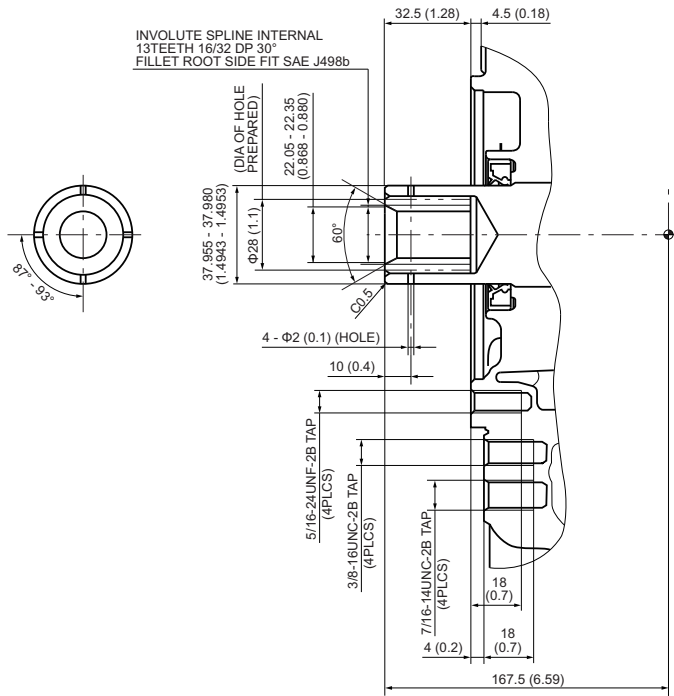

## ENGINE MOUNT DIMENSIONAL DRAWING

Unit: mm (in)

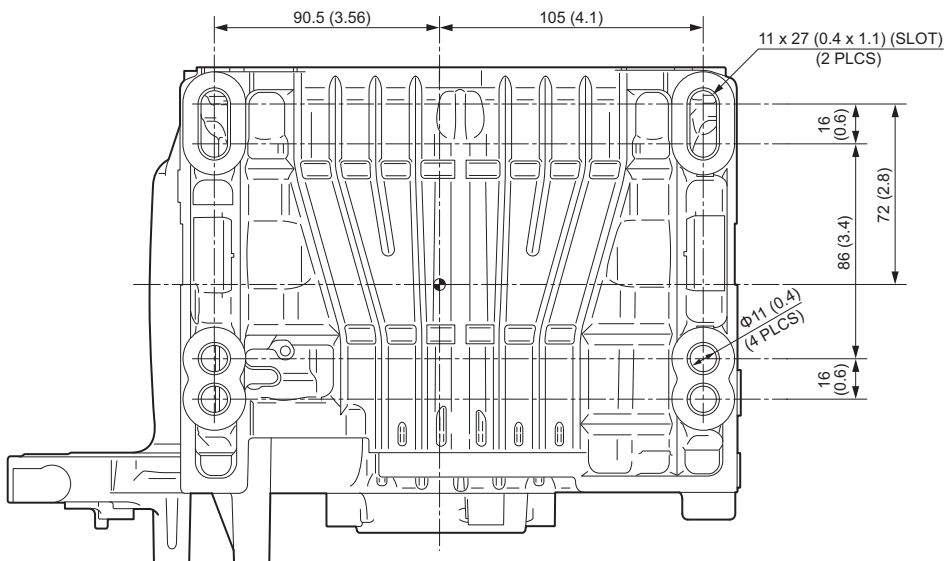

# 2. SERVICE INFORMATION

---

MAINTENANCE STANDARDS .....	2-2	TOOLS .....	2-8
TORQUE VALUES .....	2-5	HARNES ROUTING.....	2-12
LUBRICATION & SEAL POINT .....	2-7	TUBE ROUTING .....	2-19



## SERVICE INFORMATION

# MAINTENANCE STANDARDS

### GX700IRH

Unit: mm (in)

Part	Item		Standard	Service limit
Engine	Maximum speed (at no load)		3,600 ± 150 rpm	–
	Idle speed		1,400 ± 150 rpm	–
	Cylinder compression	#1 cylinder	0.6 – 0.8 MPa (6.12 – 8.16 kgf/cm <sup>2</sup> , 87 – 116 psi)/ 500 rpm	–
		#2 cylinder	0.4 – 0.6 MPa (4.08 – 6.12 kgf/cm <sup>2</sup> , 58 – 87 psi)/ 500 rpm	–
Cylinder	Sleeve I.D.		78.000 – 78.015 (3.0709 – 3.0715)	78.150 (3.0768)
Piston	Skirt O.D.		77.975 – 77.985 (3.0699 – 3.0703)	77.875 (3.0659)
	Piston-to-cylinder clearance		0.015 – 0.040 (0.0006 – 0.0016)	0.12 (0.005)
	Piston pin bore I.D.		18.002 – 18.008 (0.7087 – 0.7090)	18.042 (0.7103)
Piston pin	Pin O.D.		17.994 – 18.000 (0.7084 – 0.7087)	17.95 (0.707)
	Piston pin-to-piston pin bore clearance		0.002 – 0.014 (0.0001 – 0.0006)	0.08 (0.003)
Piston rings	Ring side clearance	Top	0.050 – 0.080 (0.0020 – 0.0031)	0.15 (0.006)
		Second	0.050 – 0.080 (0.0020 – 0.0031)	0.15 (0.006)
	Ring end gap	Top	0.200 – 0.350 (0.0079 – 0.0138)	0.450 (0.0177)
		Second	0.350 – 0.500 (0.0138 – 0.0197)	0.600 (0.0236)
		Oil (side rail)	0.20 – 0.70 (0.008 – 0.028)	0.90 (0.035)
	Ring width	Top	1.140 – 1.155 (0.0449 – 0.0455)	1.120 (0.0441)
Second		1.140 – 1.155 (0.0449 – 0.0455)	1.120 (0.0441)	
Connecting rod	Small end I.D.		18.006 – 18.018 (0.7089 – 0.7094)	18.07 (0.711)
	Big end I.D.		44.988 – 45.012 (1.7712 – 1.7721)	45.050 (1.7736)
	Big end oil clearance		0.005 – 0.039 (0.0002 – 0.0015)	0.070 (0.0028)
	Big end side clearance		0.2 – 0.4 (0.008 – 0.016)	1.000 (0.0394)
Crankshaft	Crankpin O.D.		44.973 – 44.983 (1.7706 – 1.7710)	44.920 (1.7685)
	Main journal O.D.		39.984 – 40.000 (1.5742 – 1.5748)	39.930 (1.5720)
	Thrust washer thickness		0.95 – 1.05 (0.037 – 0.041)	0.80 (0.031)
Crankcase	Camshaft bearing I.D.		17.016 – 17.027 (0.6699 – 0.6704)	17.06 (0.672)
	Main journal I.D.		40.025 – 40.041 (1.5758 – 1.5764)	40.06 (1.577)
	Crankshaft axial clearance		0.05 – 0.45 (0.002 – 0.018)	1.0 (0.04)
Crankcase cover	Camshaft bearing I.D.		17.016 – 17.027 (0.6699 – 0.6704)	17.06 (0.672)
	Main journal I.D.		40.025 – 40.041 (1.5758 – 1.5764)	40.06 (1.577)
Valves	Valve clearance	IN	0.18 – 0.22 (0.007 – 0.009)	–
		EX	0.18 – 0.22 (0.007 – 0.009)	–
	Valve stem O.D.	IN	5.475 – 5.490 (0.2156 – 0.2161)	5.400 (0.2126)
		EX	5.435 – 5.450 (0.2140 – 0.2146)	5.300 (0.2087)
	Valve guide I.D.	IN/EX	5.500 – 5.512 (0.2165 – 0.2170)	5.560 (0.2189)
	Guide-to-stem clearance	IN	0.010 – 0.037 (0.0004 – 0.0015)	0.110 (0.0043)
		EX	0.050 – 0.077 (0.0020 – 0.0030)	0.130 (0.0051)
	Valve seat width		1.0 – 1.2 (0.04 – 0.05)	2.1 (0.08)
Valve spring free length		38.3 (1.51)	36.8 (1.45)	
Valve spring perpendicularity		2° max.	–	
Camshaft	Cam height	IN	29.506 – 29.706 (1.1617 – 1.1695)	29.36 (1.156)
		EX	29.410 – 29.610 (1.1579 – 1.1657)	29.26 (1.152)
	Camshaft O.D.		16.982 – 17.000 (0.6686 – 0.6693)	17.100 (0.6732)
Valve lifter	Valve lifter I.D.		6.010 – 6.040 (0.2366 – 0.2378)	6.070 (0.2390)
	Valve lifter shaft O.D.		5.970 – 6.000 (0.2350 – 0.2362)	5.940 (0.2339)
Rocker arm	Rocker arm I.D.		6.000 – 6.018 (0.2362 – 0.2369)	6.043 (0.2379)
	Rocker arm shaft O.D.		5.960 – 5.990 (0.2346 – 0.2358)	5.953 (0.2344)
	Rocker arm shaft bearing I.D.		6.000 – 6.018 (0.2362 – 0.2369)	6.043 (0.2379)
Oil pump	Oil pressure		2.8 kgf/cm <sup>2</sup> (39.8 psi)/ 2,000 rpm and more	–
	Tip clearance		0.15 (0.006)	0.30 (0.012)
	Outer rotor-to-housing clearance		0.150 – 0.210 (0.0059 – 0.0083)	0.30 (0.012)
	Outer rotor-to-pump cover clearance		0.04 – 0.09 (0.002 – 0.004)	0.11 (0.004)
Spark plug	Gap		0.7 – 0.8 (0.028 – 0.031)	–

## SERVICE INFORMATION

Part	Item		Standard	Service limit
Starter motor	Brush length		10 (0.4)	6.0 (0.2)
	Mica depth		–	0.2 (0.01)
Charge coil	Resistance	17 A	0.18 – 0.28 Ω	–
		26 A	0.17 – 0.25 Ω	–
Fuel injector	Resistance	24°C (75 °F)	11 – 13 Ω	–
TE sensor	Resistance	40°C (104 °F)	1.1 – 1.4 kΩ	–
		100 °C (212 °F)	0.1 – 0.3 kΩ	–
CKP sensor	Resistance		216 – 264 Ω	–
Ignition coil	Resistance	Primary	1.8 – 2.8 Ω	–
		Secondary	7.4 – 11.2 kΩ	–

## SERVICE INFORMATION

### GX800IRH

Unit: mm (in)

Part	Item	Standard	Service limit	
Engine	Maximum speed (at no load)	3,600 ± 150 rpm	–	
	Idle speed	1,400 ± 150 rpm	–	
	Cylinder compression	#1 cylinder	0.63 – 0.83 MPa (6.42 – 8.46 kgf/cm <sup>2</sup> , 91 – 120 psi)/ 500 rpm	–
		#2 cylinder	0.32 – 0.52 MPa (3.26 – 5.30 kgf/cm <sup>2</sup> , 46 – 75 psi)/ 500 rpm	–
Cylinder	Sleeve I.D.	83.000 – 83.015 (3.2677 – 3.2683)	83.093 (3.2714)	
Piston	Skirt O.D.	82.975 – 82.985 (3.2667 – 3.2671)	82.880 (3.2630)	
	Piston-to-cylinder clearance	0.015 – 0.040 (0.0006 – 0.0016)	0.12 (0.005)	
	Piston pin bore I.D.	18.002 – 18.008 (0.7087 – 0.7090)	18.042 (0.7103)	
Piston pin	Pin O.D.	17.994 – 18.000 (0.7084 – 0.7087)	17.95 (0.707)	
	Piston pin-to-piston pin bore clearance	0.002 – 0.014 (0.0001 – 0.0006)	0.08 (0.003)	
Piston rings	Ring side clearance	Top	0.050 – 0.080 (0.0020 – 0.0031)	0.15 (0.006)
		Second	0.050 – 0.080 (0.0020 – 0.0031)	0.15 (0.006)
	Ring end gap	Top	0.200 – 0.300 (0.0079 – 0.0118)	0.400 (0.0157)
		Second	0.300 – 0.400 (0.0118 – 0.0157)	0.500 (0.0197)
		Oil (side rail)	0.20 – 0.50 (0.0080 – 0.0197)	0.70 (0.0276)
	Ring width	Top	1.140 – 1.155 (0.0449 – 0.0455)	1.120 (0.0441)
Second		1.140 – 1.155 (0.0449 – 0.0455)	1.120 (0.0441)	
Connecting rod	Small end I.D.	18.006 – 18.018 (0.7089 – 0.7094)	18.07 (0.711)	
	Big end I.D.	44.988 – 45.012 (1.7712 – 1.7721)	45.050 (1.7736)	
	Big end oil clearance	0.005 – 0.039 (0.0002 – 0.0015)	0.070 (0.0028)	
	Big end side clearance	0.2 – 0.4 (0.008 – 0.016)	1.000 (0.0394)	
Crankshaft	Crankpin O.D.	44.973 – 44.983 (1.7706 – 1.7710)	44.920 (1.7685)	
	Main journal O.D.	39.984 – 40.000 (1.5742 – 1.5748)	39.930 (1.5720)	
	Thrust washer thickness	0.95 – 1.05 (0.037 – 0.041)	0.80 (0.031)	
Crankcase	Camshaft bearing I.D.	17.016 – 17.027 (0.6699 – 0.6704)	17.06 (0.672)	
	Main journal I.D.	40.025 – 40.041 (1.5758 – 1.5764)	40.06 (1.577)	
	Crankshaft axial clearance	0.05 – 0.45 (0.002 – 0.018)	1.0 (0.04)	
Oil pan	Camshaft bearing I.D.	17.016 – 17.027 (0.6699 – 0.6704)	17.06 (0.672)	
	Main journal I.D.	40.025 – 40.041 (1.5758 – 1.5764)	40.06 (1.577)	
Valves	Valve clearance	IN	0.18 – 0.22 (0.007 – 0.009)	–
		EX	0.18 – 0.22 (0.007 – 0.009)	–
	Valve stem O.D.	IN	5.475 – 5.490 (0.2156 – 0.2161)	5.400 (0.2126)
		EX	5.435 – 5.450 (0.2140 – 0.2146)	5.300 (0.2087)
	Valve guide I.D.	IN/EX	5.500 – 5.512 (0.2165 – 0.2170)	5.560 (0.2189)
	Guide-to-stem clearance	IN	0.010 – 0.037 (0.0004 – 0.0015)	0.110 (0.0043)
		EX	0.050 – 0.077 (0.0020 – 0.0030)	0.130 (0.0051)
	Valve seat width		1.0 – 1.2 (0.04 – 0.05)	2.1 (0.08)
Valve spring free length		38.3 (1.51)	36.8 (1.45)	
Camshaft	Cam height	IN	29.878 – 30.078 (1.1763 – 1.1842)	29.848 (1.1751)
		EX	29.598 – 29.798 (1.1653 – 1.1731)	29.568 (1.1641)
	Camshaft O.D.		16.982 – 17.000 (0.6686 – 0.6693)	17.100 (0.6732)
Valve lifter	Valve lifter I.D.	6.010 – 6.040 (0.2366 – 0.2378)	6.070 (0.2390)	
	Valve lifter shaft O.D.	5.970 – 6.000 (0.2350 – 0.2362)	5.940 (0.2339)	
Rocker arm	Rocker arm I.D.	6.000 – 6.018 (0.050 – 0.077)	6.043 (0.2379)	
	Rocker arm shaft O.D.	5.960 – 5.990 (0.2346 – 0.2358)	5.953 (0.2344)	
	Rocker arm shaft bearing I.D.	6.000 – 6.018 (0.050 – 0.077)	6.043 (0.2379)	
Oil pump	Oil pressure	2.8 kgf/cm <sup>2</sup> (39.8 psi)/ 2,000 rpm and more	–	
	Tip clearance	0.15 (0.006)	0.30 (0.012)	
	Outer rotor-to-housing clearance	0.150 – 0.210 (0.0059 – 0.0083)	0.30 (0.012)	
	Outer rotor-to-pump cover clearance	0.04 – 0.09 (0.002 – 0.004)	0.11 (0.004)	
Spark plug	Gap	0.7 – 0.8 (0.028 – 0.031)	–	
Starter motor	Brush length	10 (0.4)	6.0 (0.2)	
	Mica depth	–	0.2 (0.01)	

Part	Item	Standard	Service limit
Charge coil	Resistance	17 A	0.18 – 0.28 Ω
		26 A	0.17 – 0.25 Ω
Fuel injector	Resistance	24°C (75 °F)	11 – 13 Ω
TE sensor	Resistance	40°C (104 °F)	1.1 – 1.4 kΩ
		100 °C (212 °F)	0.1 – 0.3 kΩ
CKP sensor	Resistance		216 – 264 Ω
Ignition coil	Resistance	Primary	1.8 – 2.8 Ω
		Secondary	7.4 – 11.2 kΩ

## TORQUE VALUES

### ENGINE TORQUE VALUES

Item	Thread Dia. (mm)	Torque values		
		N·m	kgf·m	lbf·ft
Spark plug	M14 x 1.25	18	1.8	13.3
Cylinder nut	M10 x 1.25	37	3.8	27
Oil drain plug bolt	M20 x 1.5	45	4.5	33
Oil filter holder	M20 x 1.5	18	1.8	13.3
Oil filter cartridge	M20 x 1.5	12	1.2	9.0
Connecting rod bolt	M7 x 1.0	22	2.2	16
Tappet adjusting nut	M5 x 0.5	7.5	0.8	5.5
Flywheel nut	M20 x 1.5	245	25	181
Fuel pump cover screw	M5 tapping screw	4.2	0.4	3.1
Fan cover protector screw	M4 special screw	1.7	0.2	1.3
Fan cover screw	M6 x 1.0 special screw	4.4	0.5	3.2
Oil pressure switch	PT1/8	9.0	0.9	6.6
Air cleaner wing nut	M6 x 1.0	0.8	0.1	0.6
Starter motor terminal nut	M8 x 1.25	9.0	0.9	6.6
Sealing bolt	PT1/8	9.0	0.9	6.6
Breather valve screw	M3 x 0.5	1.0	0.1	0.7
Control cover screw	M5 tapping screw	3.2	0.3	2.4
Hour meter screw	M3 tapping screw	0.4	0.1	0.3
Switch box screw	M5 tapping screw	3.2	0.3	2.4
Combination switch nut	M22 x 1.0	4.9	0.5	3.6
Control panel screw	M5 x 0.8	5.2	0.5	3.8
Speed volume nut	M10 x 0.75	1.1	0.1	0.8
Fuel pump (low pressure side) screw	M6 x 1.0	5.0	0.5	3.7
Oil hose	PT1/8	9.0	0.9	6.6
Inlet manifold bolt	M8 x 1.25	19	1.9	14
Drain cap	3/8-18 NPTF	–	–	–
Front P.T.O. shaft	M8 x 1.25	34	3.5	25
TE sensor	M10 x 1.25	12	1.2	9.0
Elbow bolt	M6 x 1.0	13.5	1.4	10
Relay bracket screw	M6 x 1.0	5.0	0.5	3.7
Fuel pump (high pressure side) bolt	M6 x 1.0	9.3	1.0	6.9

### STANDARD TORQUE VALUES

Item	Thread Dia. (mm)	Torque values		
		N·m	kgf·m	lbf·ft
Screw	4 mm	2.1	0.2	1.5
	5 mm	4.2	0.4	3.1
	6 mm	9.0	0.9	6.6
Bolt and nut	4 mm	3.4	0.4	2.5
	5 mm	5.2	0.5	3.8
	6 mm	10	1.0	7.0
	8 mm	22	2.2	16
	10 mm	34	3.5	25
	12 mm	54	5.5	40

## SERVICE INFORMATION

Item	Thread Dia. (mm)	Torque values		
		N·m	kgf·m	lbf·ft
Flange bolt and nut	5 mm	5.3	0.5	3.9
	6 mm	12	1.2	9.0
	8 mm	27	2.7	20
	10 mm	39	4.0	29
SH (Small head) flange bolt	6 mm	9.0	0.9	7.0



**LUBRICATION & SEAL POINT**

Material	Location	Remarks
Engine oil	Crankshaft gear	
	Piston outer surface and piston pin hole	
	Connecting rod bolt threads and seating surface	
	Camshaft cam profile, bearing, decompressor and gear	
	Valve lifter shaft and slipper	
	Valve stem seal contact area of seal lip	
	Valve stem sliding surface and stem end	
	Valve spring	
	Push rod end	
	Rocker arm bearing and slipper	
	Tappet adjusting screw and nut threads and seating surface	
	Rocker arm shaft	
	Crankshaft thrust washer	
	Flywheel nut threads and seating surface	
	Oil pump gear outer surface and rotor	
	Governor weight holder gear and journal	
	Cylinder nut and bolt threads and seating surface	
	Oil seal outer surface	
	Oil filter cartridge O-ring	
Use molybdenum oil solution (mixture of the engine oil and molybdenum grease in a ratio of 1:1)	Crankshaft pin and journal	
	Crankcase bearing	
	Oil pan bearing	
	Piston pin outer surface	
	Piston ring	
	Cylinder inner surface	
	Connecting rod big and small end bearing	
	Oil pump shaft	
Multi-purpose grease	Oil seal lip	
	O-ring	
Liquid sealant (Threebond®1207B)	Cylinder	
	Oil pan	
	Breather cover	
Liquid sealant (Threebond®1207B, 1141G or 1215)	Oil pressure switch	
	Sealing bolt	
2 cycle oil	Tube end	

# SERVICE INFORMATION

## TOOLS

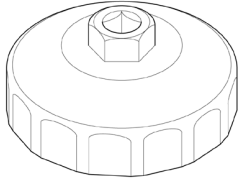
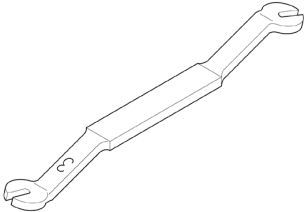
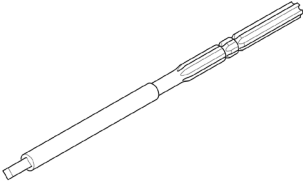
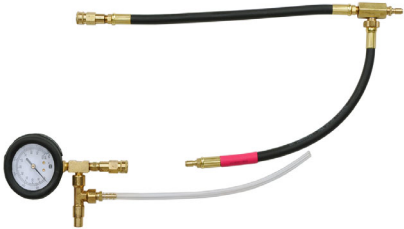
### Special Tools

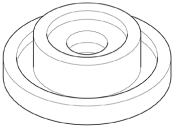
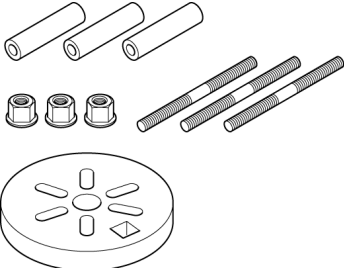
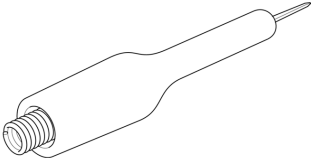
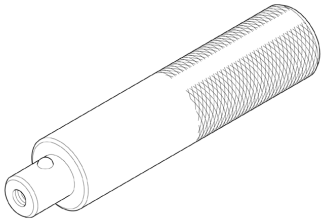
<p>Oil filter wrench 64 mm 07HAA-PJ70101</p> 	<p>Tappet adjusting wrench 3 mm 07908-KE90200</p> 	<p>Valve guide reamer 5.510 mm 07984-200000D</p> 
<p>Fuel pressure gauge 07APJ-Z37A101</p> 	<p>Fuel pressure adapter "C" 07AAJ-S6MA300</p> 	<p>Fuel pressure adapter, 90° "C" 07APJ-ZEAA100</p> 
<p>Oil seal driver attachment 60 mm 07GAD-PG40100</p> 	<p>Flywheel puller 070PC-ZDW0100</p> 	<p>Test probe (2 pack) 07ZAJ-RDJA110</p> 
<p>Driver 07749-0010000</p> 		

**Commercially Available Tools**

ITEM	TOOL NAME	TOOL NUMBER	APPLICATION
1	Oil pressure gauge set	EEPV507	Oil pressure test
2	Cleaning brush	Procured locally	Clean combustion chamber
3	Cutter holder 5.5 mm	Procured locally	Valve seat reconditioning
4	Seat cutter 27.5 mm (45° EX)	Procured locally	Valve seat reconditioning
5	Seat cutter 33 mm (45° IN)	Procured locally	Valve seat reconditioning
6	Interior cutter 26 mm (60° EX)	Procured locally	Valve seat reconditioning
7	Flat cutter 30 mm (32° EX)	Procured locally	Valve seat reconditioning
8	Flat cutter 33 mm (32° IN)	Procured locally	Valve seat reconditioning
9	Interior cutter 30 mm (60° IN)	Procured locally	Valve seat reconditioning
10	Cylinder compression gauge	EEPV503	Cylinder compression check

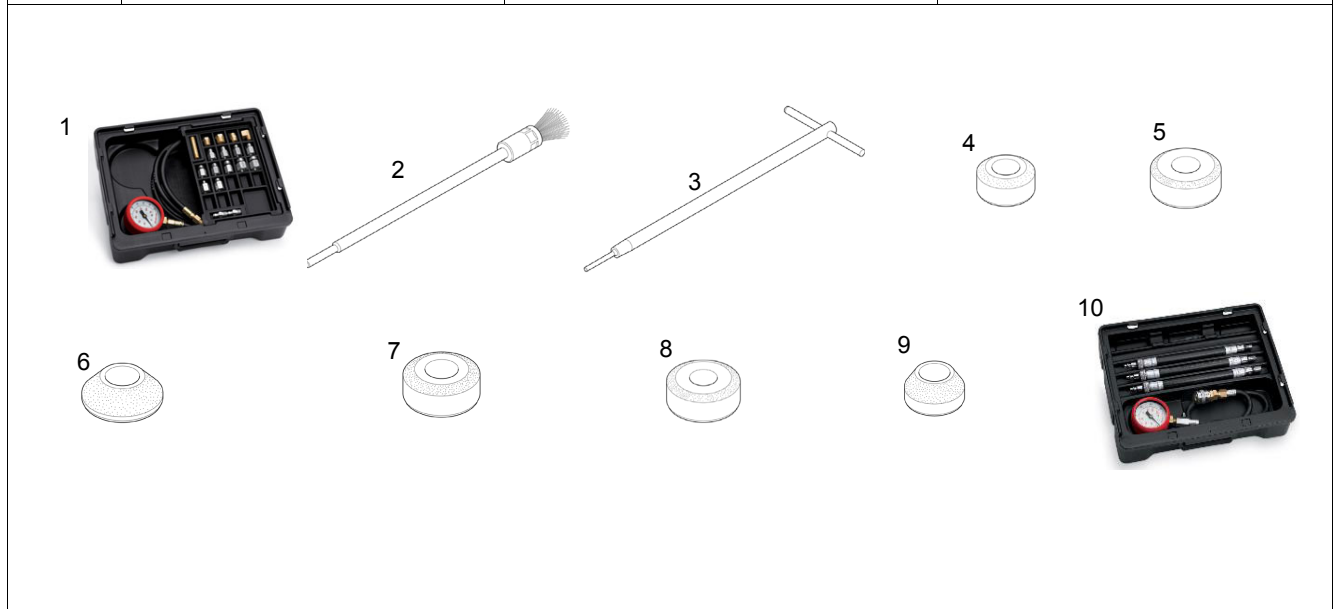

Commercially available tools are distinguished by the words (commercially available). They are not available through the American Honda Parts Department. Most commercially available tools shown in this shop manual can be ordered through the Honda Power Equipment (P/E) Tool and Equipment program by calling (888) 424-6857. Refer to the Tool and Equipment program catalog for a complete tool listing.



# SERVICE INFORMATION

## HARNESS ROUTING

CONTROL BOX TYPE:

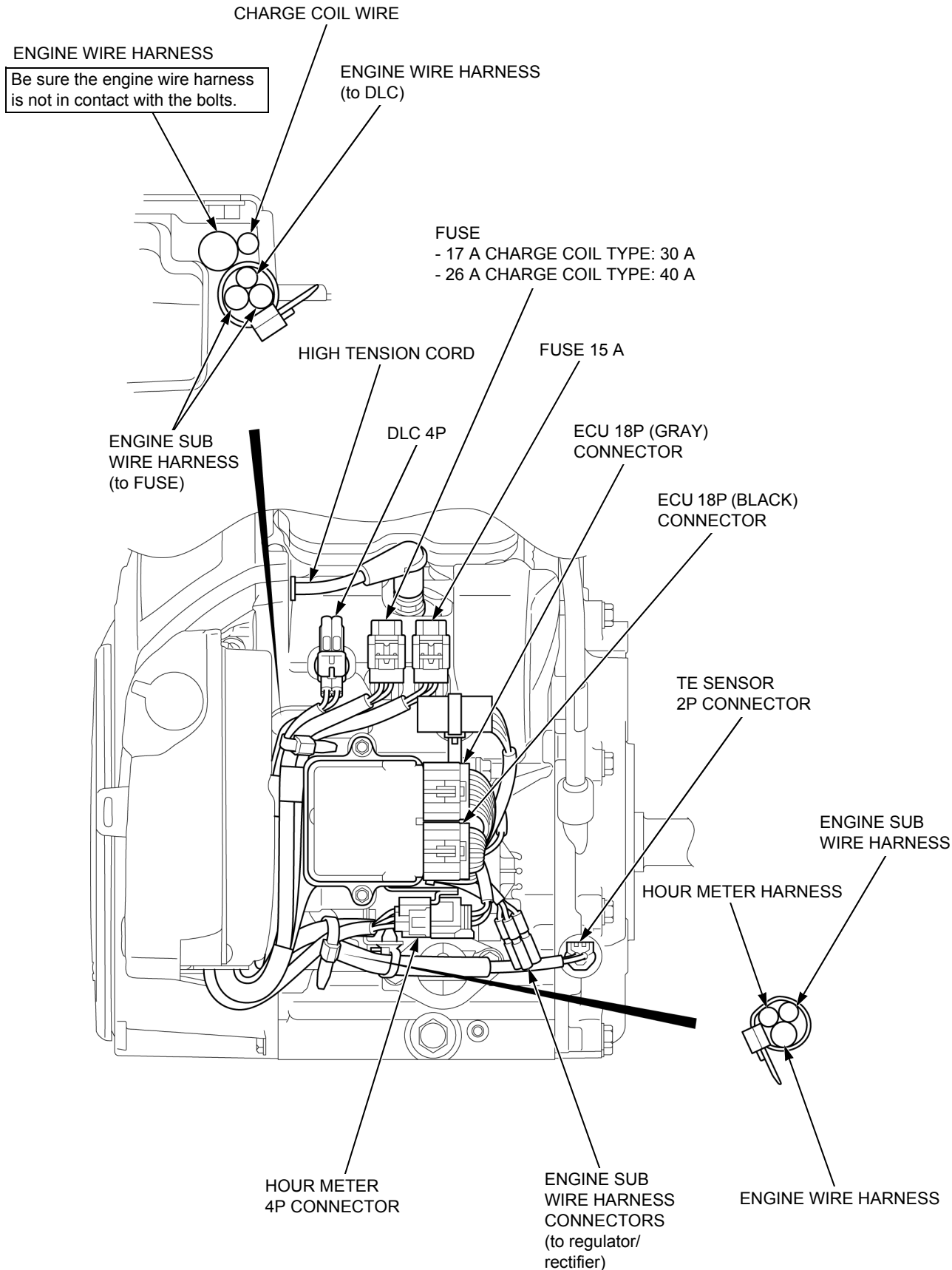

REMOTE TYPE:

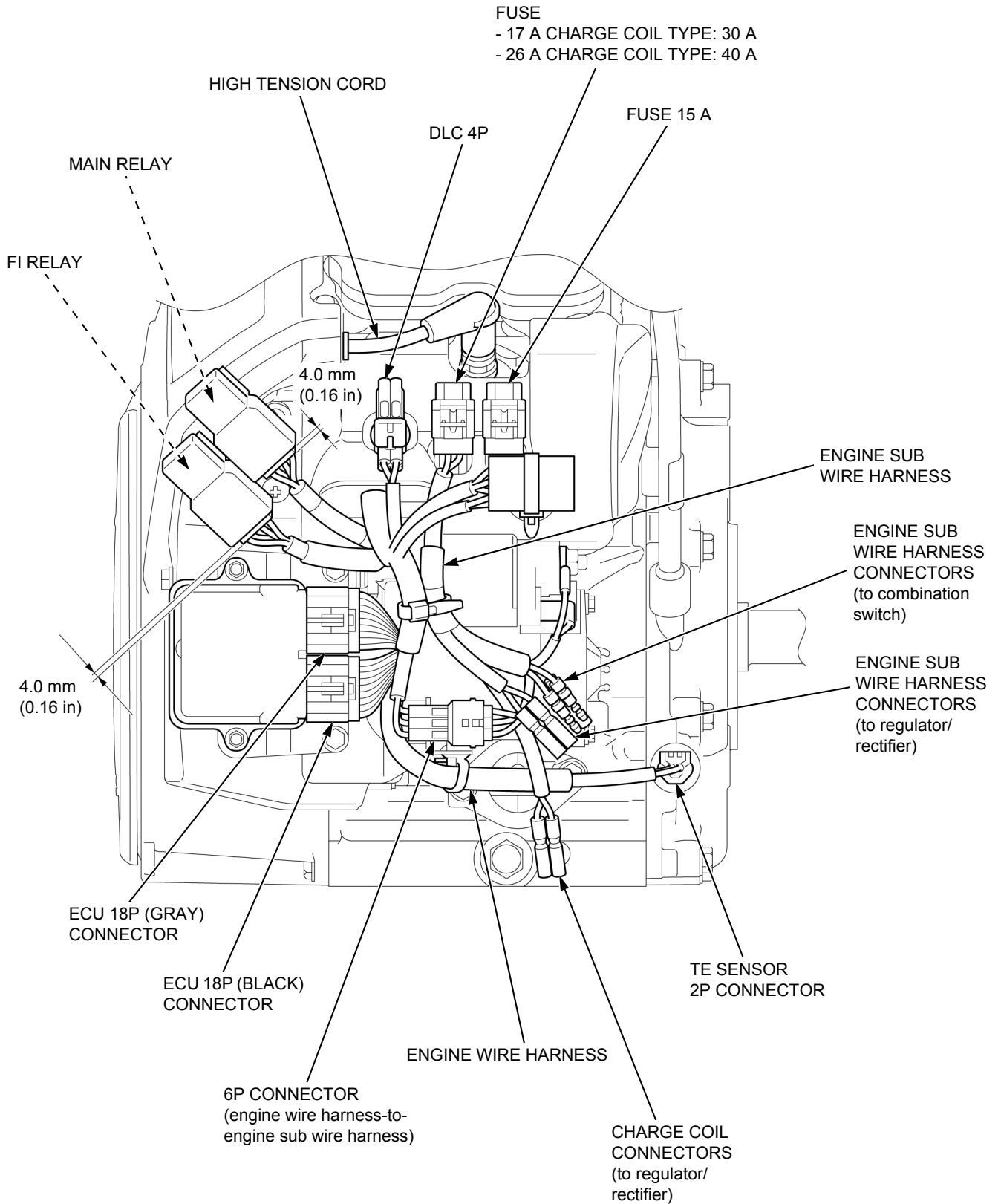

## SERVICE INFORMATION

---

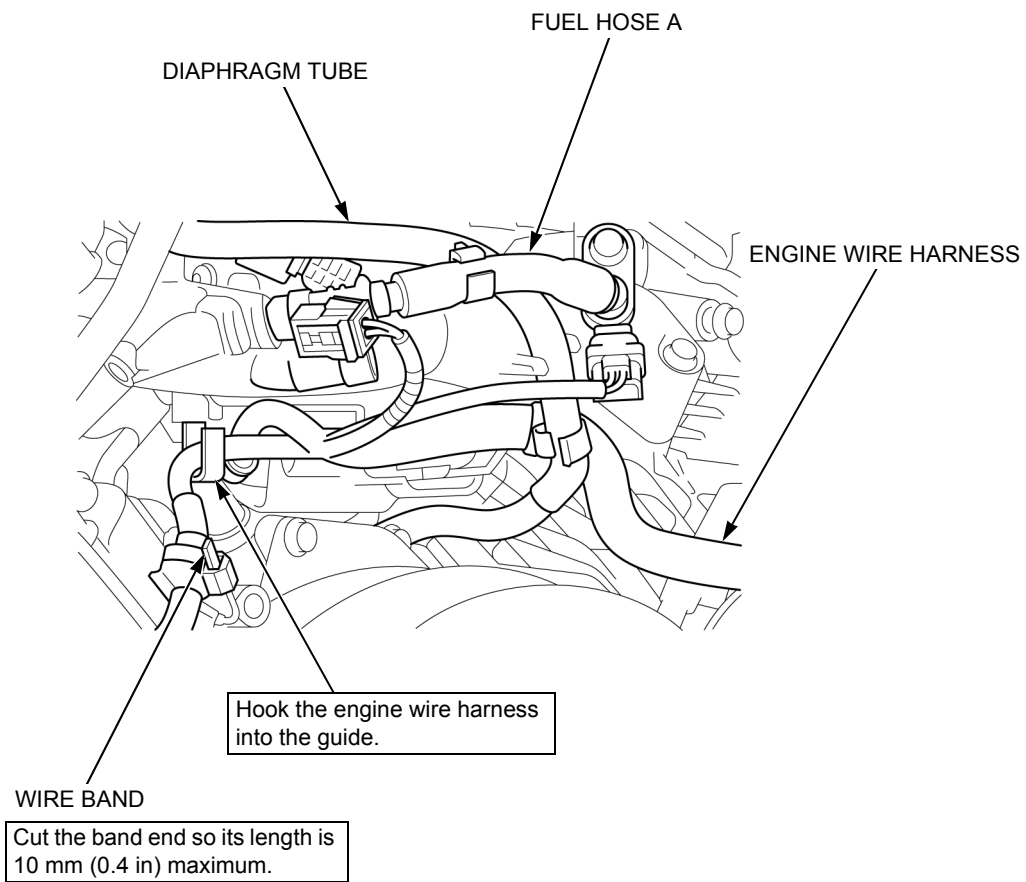
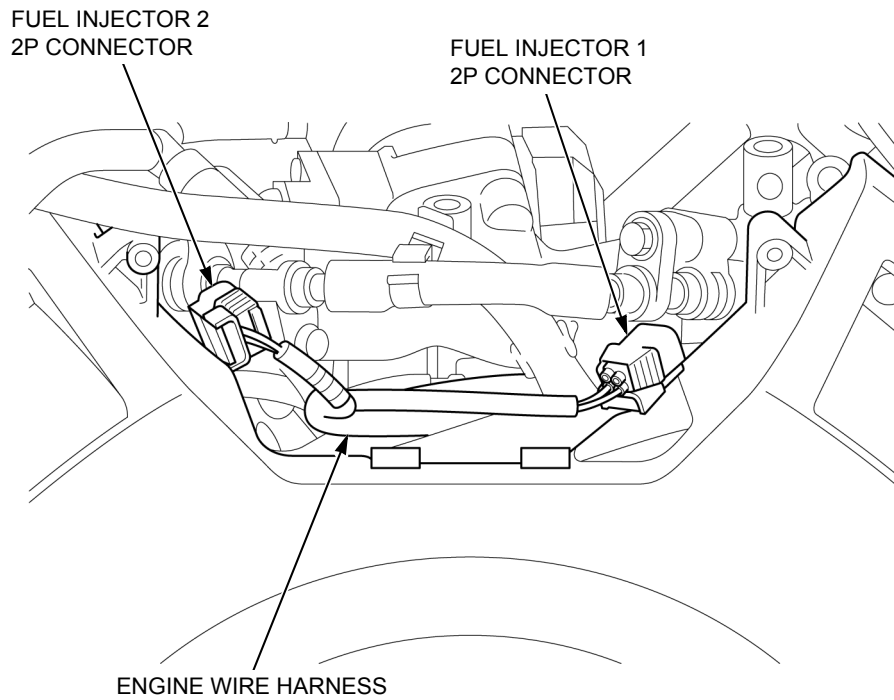

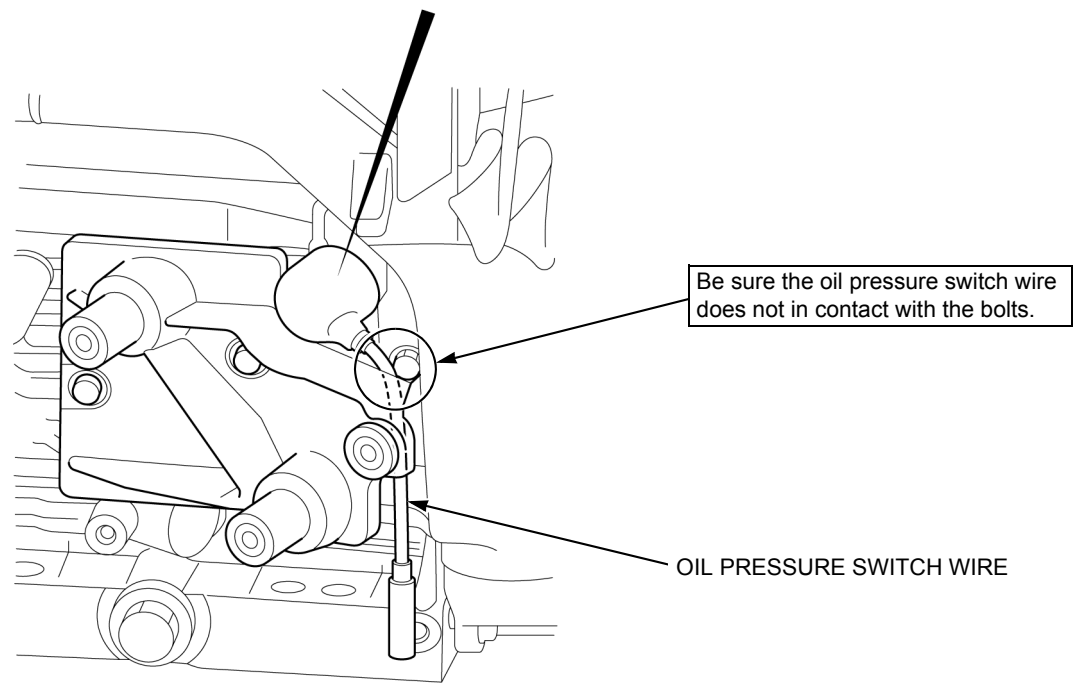
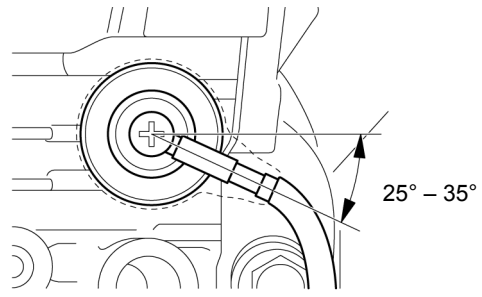
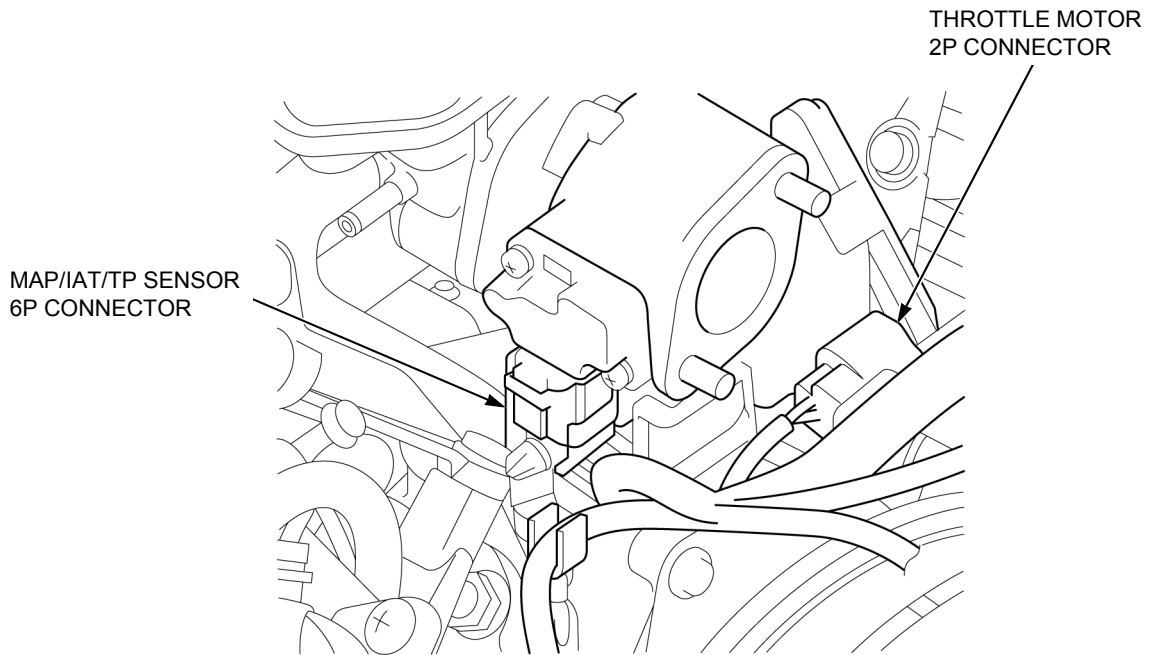

# SERVICE INFORMATION

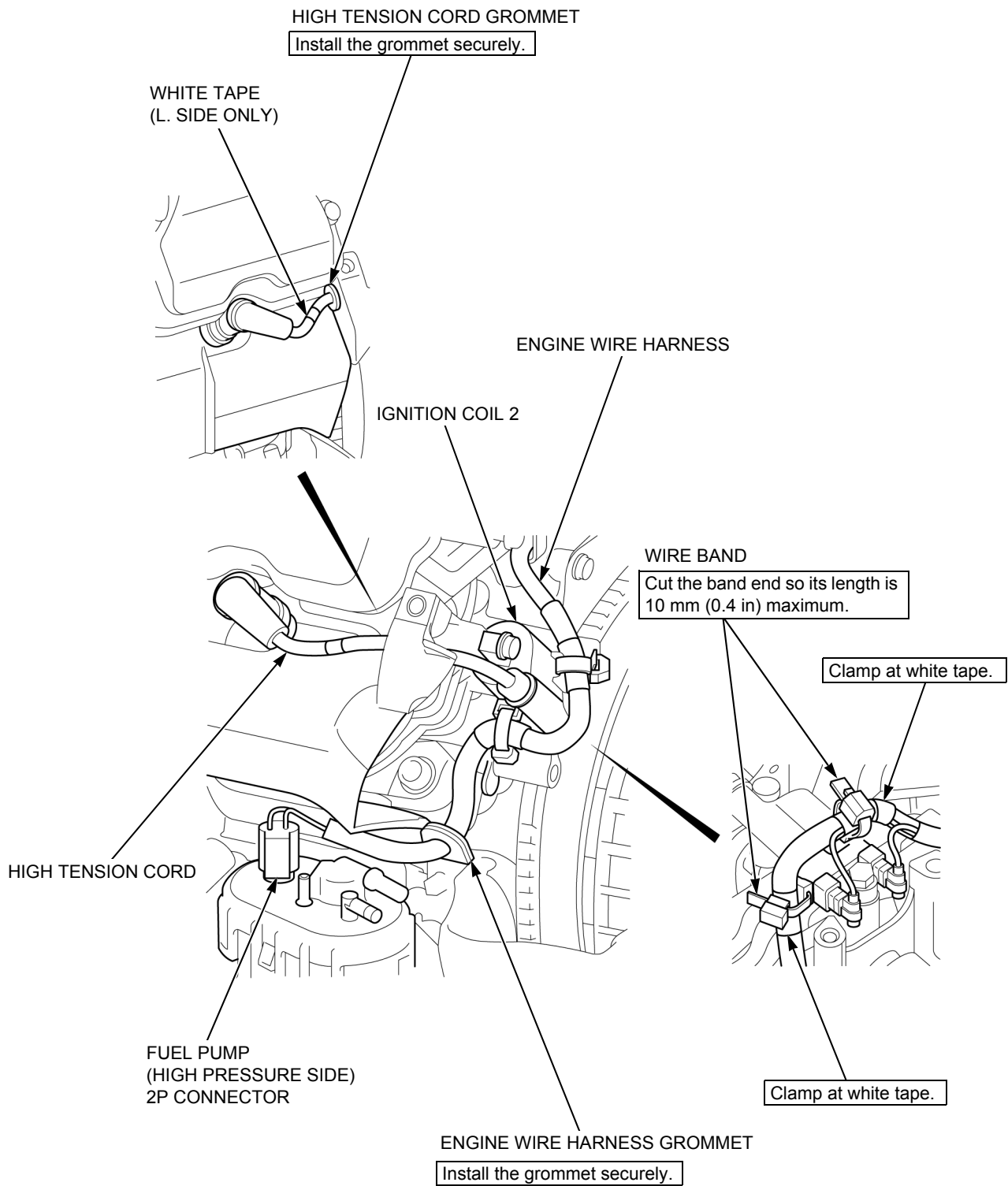

CHARGE COIL CORD

There should be no slack and do not pinch.

IGNITION COIL 1

Clamp at white tape.

ENGINE WIRE HARNESS

Contact.

WIRE BAND

Cut the band end so its length is 10 mm (0.4 in) maximum.

Route the engine wire harness into the guide.

ENGINE WIRE HARNESS  
(to CKP sensor)

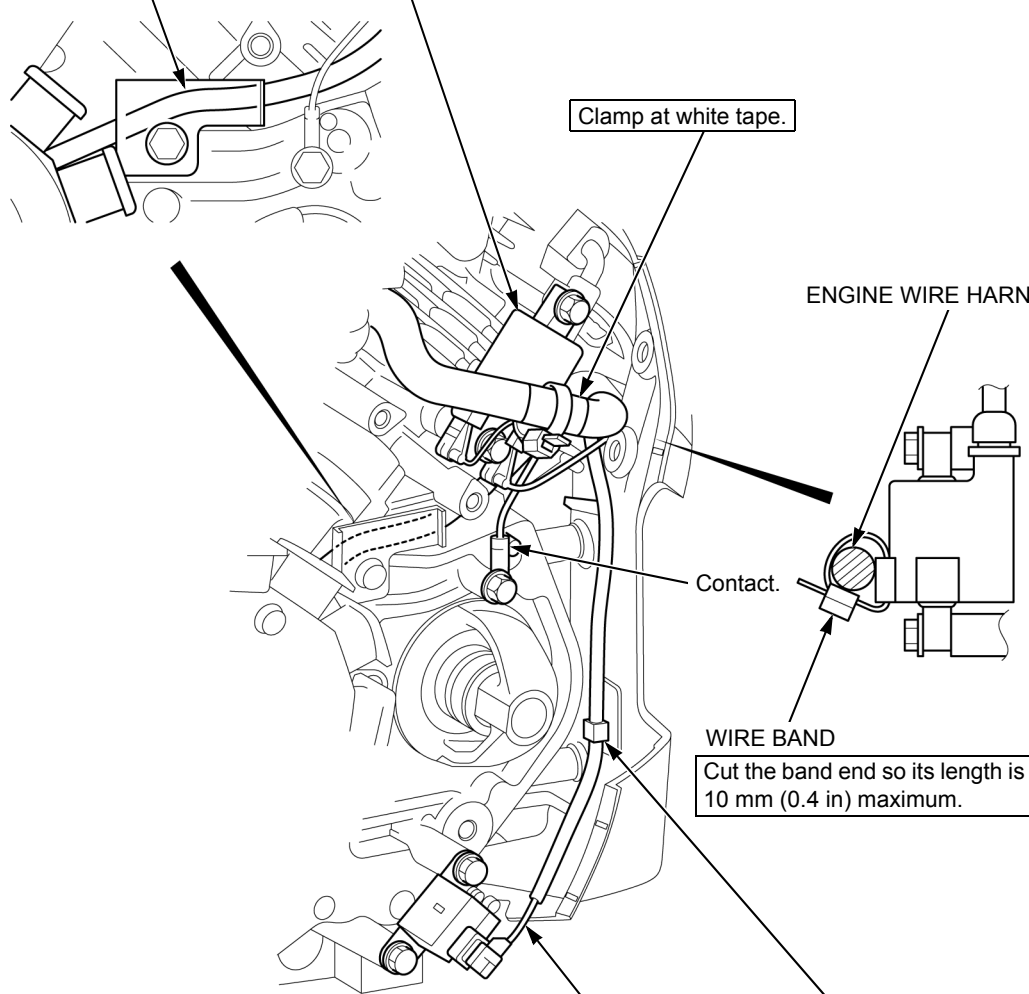

# SERVICE INFORMATION

CONTROL BOX TYPE SHOWN:

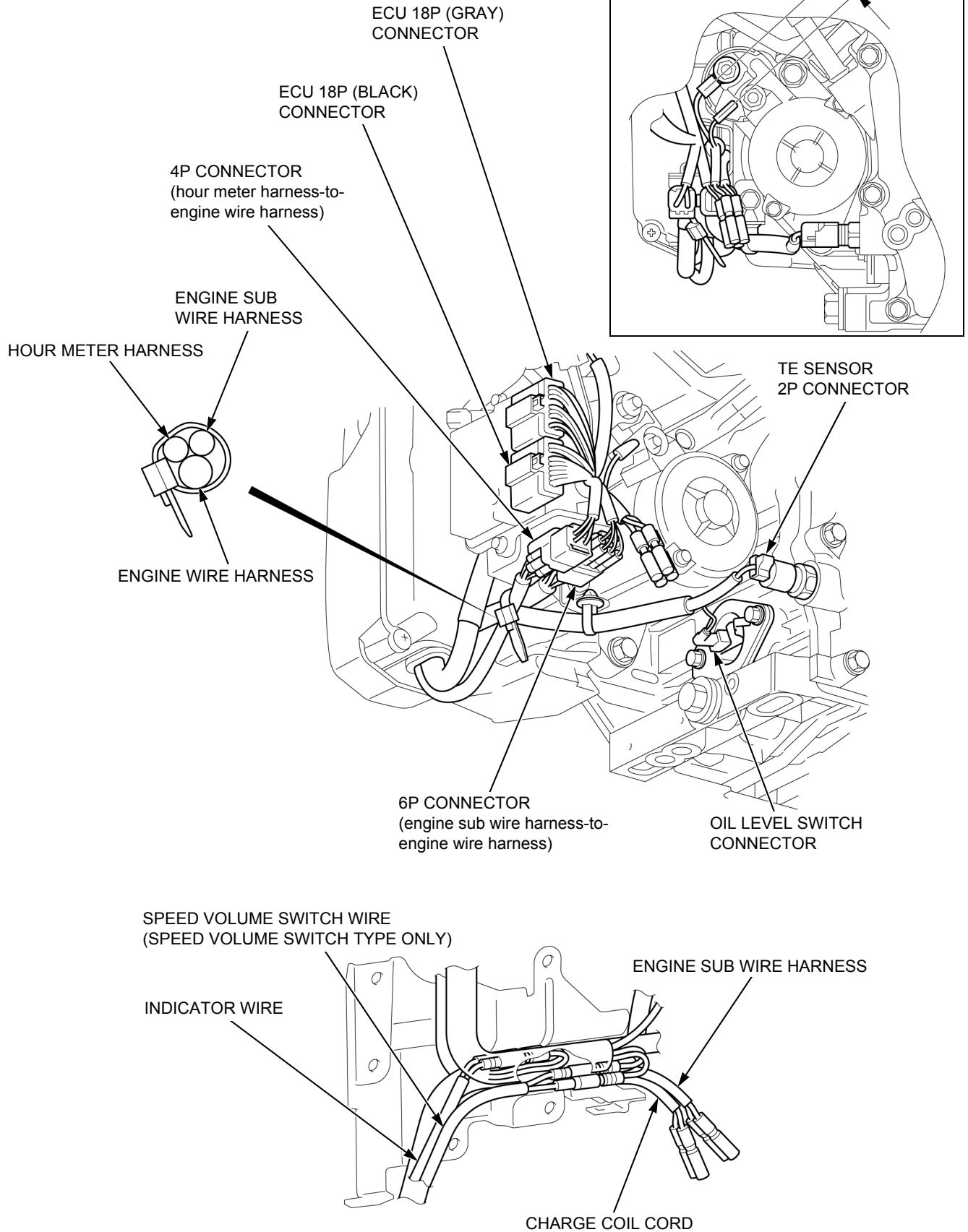

# TUBE ROUTING

Be sure to insert the hose and tube to the end face securely.

*1: 1.0 – 2.0 mm (0.04 – 0.08 in)	*2: 2.0 – 3.0 mm (0.08 – 0.12 in)	*3: 3.0 – 5.0 mm (0.12 – 0.20 in)
--------------------------------------	--------------------------------------	--------------------------------------

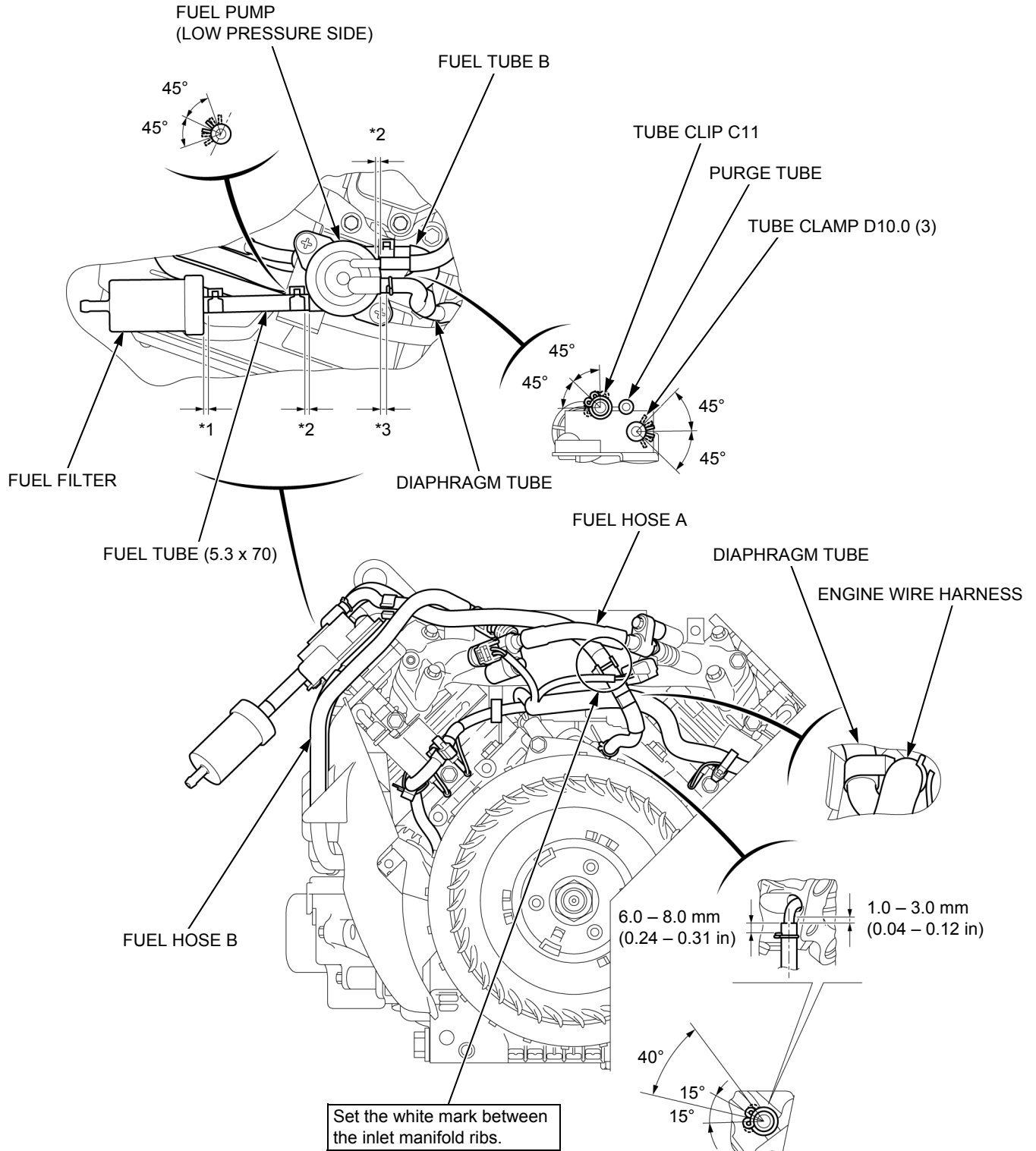



# SERVICE INFORMATION

Be sure to insert the hose and tube to the end face securely.

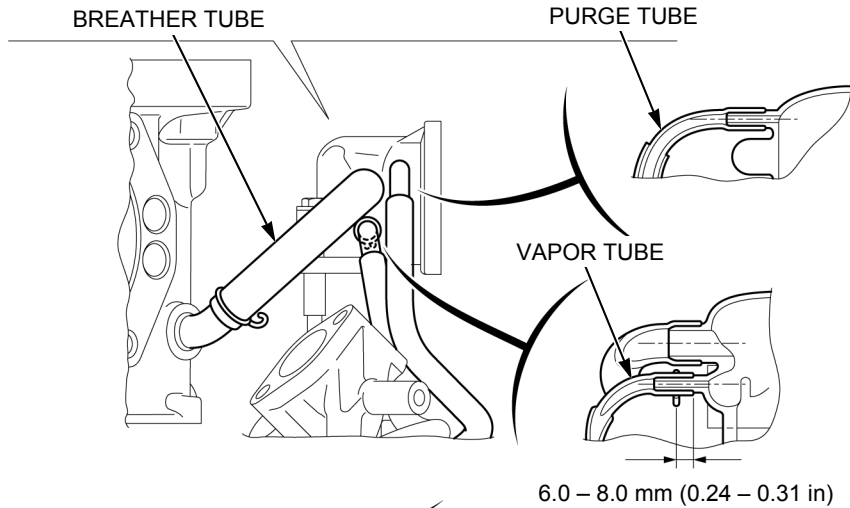
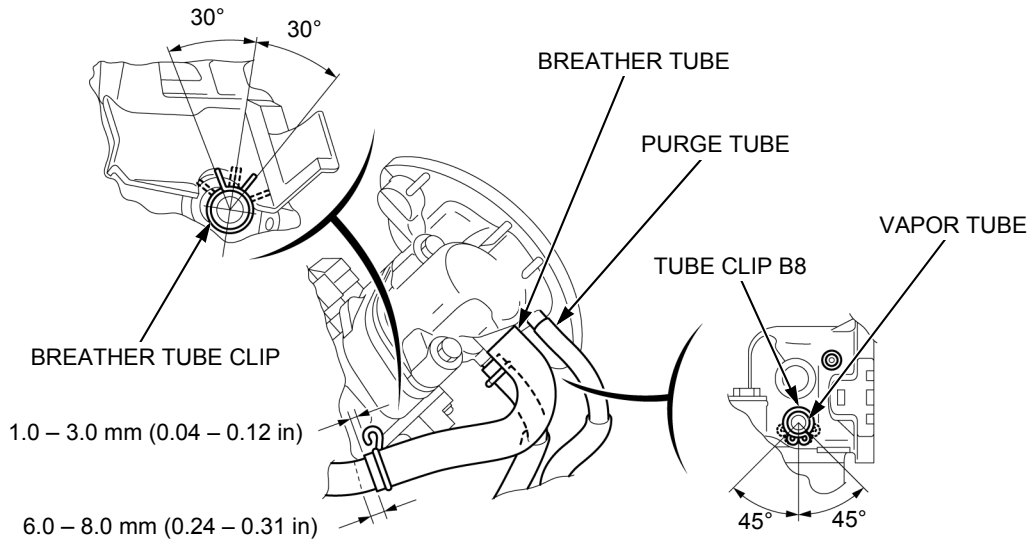

Route the purge tube between the rib.

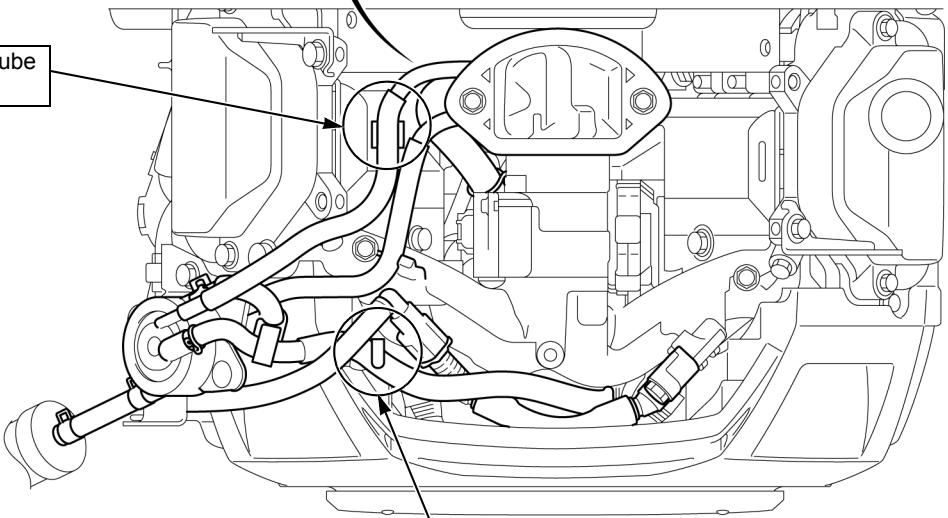

Clamp the diaphragm tube by the fan cover guide.

Be sure to insert the hose and tube to the end face securely.

\*1: Route the tubes and hose between L. lower shroud ribs and insert them fully.

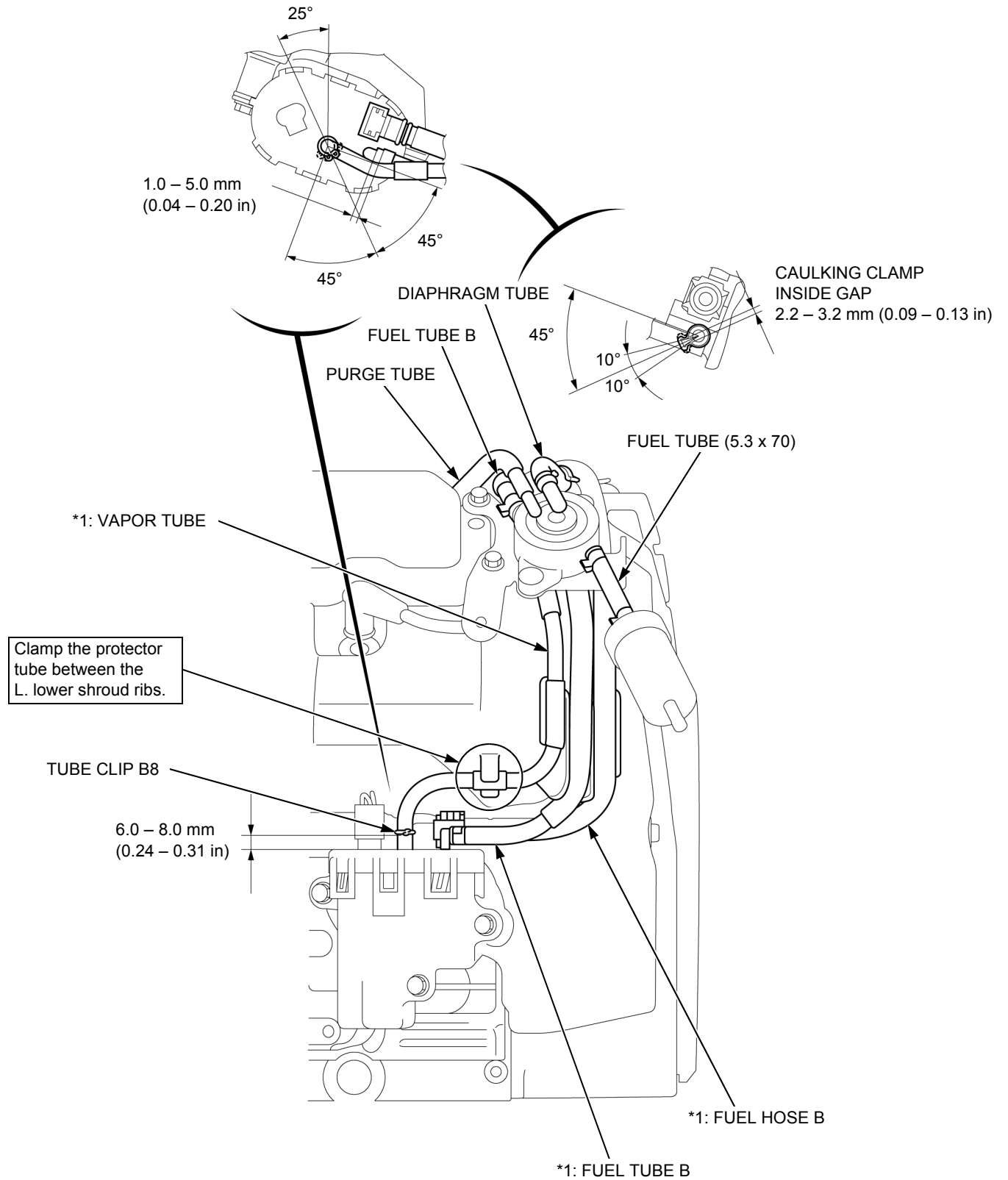

# SERVICE INFORMATION

Be sure to insert the hose and tube to the end face securely.

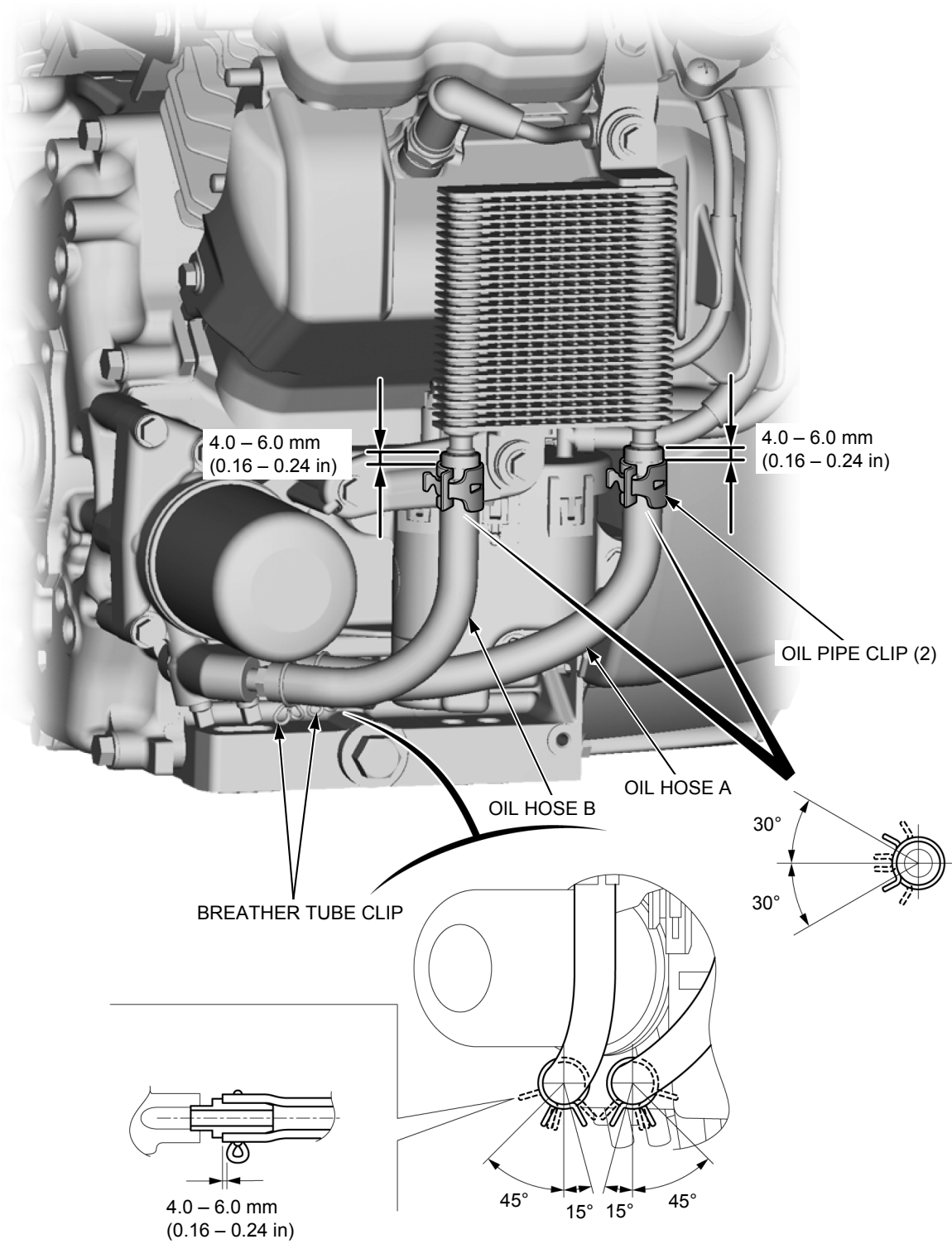

MAINTENANCE SCHEDULE .....	3-2	SPARK PLUG REPLACEMENT .....	3-7
ENGINE OIL LEVEL CHECK .....	3-3	SPARK ARRESTER CLEANING .....	3-8
ENGINE OIL CHANGE .....	3-4	VALVE CLEARANCE CHECK/ ADJUSTMENT .....	3-8
OIL FILTER REPLACEMENT .....	3-4	COMBUSTION CHAMBER CLEANING .....	3-10
AIR CLEANER CHECK/CLEANING .....	3-5	FUEL FILTER REPLACEMENT .....	3-11
AIR CLEANER REPLACEMENT .....	3-6	FUEL TUBE CHECK .....	3-11
SPARK PLUG CHECK/ADJUSTMENT .....	3-6		

## MAINTENANCE

# MAINTENANCE SCHEDULE

REGULAR SERVICE PERIOD (1)		Each use	First month or 20 hrs.	Every 6 months or 100 hrs.	Every year or 300 hrs.	Every 2 years or 500 hrs.	Refer to page
ITEM	Perform at every indicated month or operating hour interval, whichever comes first.						
Engine oil	Check level	○					3-3
	Change		○	○			3-4
Engine oil filter	Replace		Every 200 hours				3-4
Air cleaner	Check	○					3-5
	Clean			○ (2)			3-5
	Replace					○ (*)	3-6
Screen grid (Applicable types)	Check	○ (3)					
Oil cooler (Applicable types)	Check	○ (3)					
Spark plug	Check-adjust			○			3-6
	Replace				○		3-7
Spark arrester (Applicable types)	Clean			○			3-8
Valve clearance	Check-adjust				○		3-8
Combustion chamber	Clean		After every 1,000 hours (3)				3-8
Fuel filter	Replace				○		3-11
Fuel tube	Check		Every 2 years (Replace if necessary)				3-11

(\*) Replace paper element type only.

(1) For commercial use, log hours of operation to determine proper maintenance intervals.

(2) Service more frequently when used in dusty areas.

(3) If there are deposits of grass, trash, or other debris, clean regularly.

# ENGINE OIL LEVEL CHECK

Place the engine on a level surface.

Start the engine and allow it to warm up for 1 to 2 minutes.

Remove the oil level dipstick [1], and wipe it clean.

Insert the oil level dipstick into the oil level pipe [2].

Remove the oil level dipstick and check oil level shown on the tip of the level dipstick.

If the oil level is near or below the lower level mark [3] on the oil level dipstick, remove the oil filler cap [4] from the head cover and fill with recommended oil to the upper level mark [5] of the level dipstick.

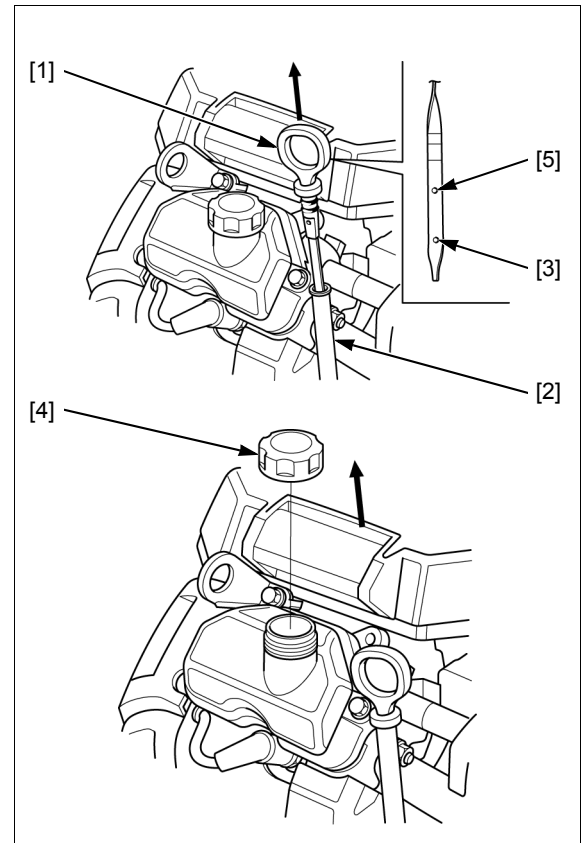

Oil is a major factor affecting performance and service life. Use 4 - stroke automotive detergent oil.

SAE 5W-30 or 10W-30 is recommended for general use. Use a full synthetic 5W-30 for starting/operating temperatures between  $-15^{\circ}\text{C}$  ( $5^{\circ}\text{F}$ ) and  $-30^{\circ}\text{C}$  ( $-22^{\circ}\text{F}$ ). Other viscosities shown in the chart may be used when the average temperature in your area is within the recommended range.

**RECOMMENDED OIL:**  
**SAE 5W-30 or 10W-30**  
**API service classification SJ or later**

Tighten the oil filler cap and install the oil level dipstick securely.

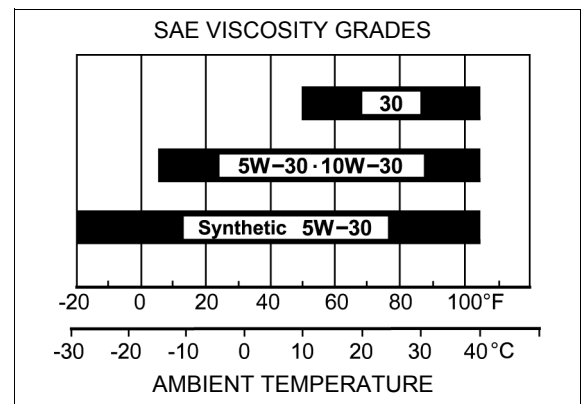

## ENGINE OIL CHANGE

Drain the oil in the engine while the engine is warm. Warm oil drains quickly and completely.

Place the engine on a level surface and place a suitable container under the drain plug bolt [1].

Remove the oil filler cap [2] from the head cover [3] and the drain plug bolt to drain the oil into a suitable container.

Please dispose of used motor oil in a manner that is compatible with the environment. We suggest you take used oil in a sealed container to your local recycling center or service station for reclamation. Do not throw it in the trash, pour it into the ground, or down a drain.

### ⚠ CAUTION

Used engine oil contains substances that have been identified as carcinogenic. If repeatedly left in contact with the skin for prolonged periods, it may cause skin cancer. Wash your hands thoroughly with soap and water as soon as possible after contact with used engine oil.

Install a new drain plug washer [4] and tighten the drain plug bolt to the specified torque.

**TORQUE: 45 N·m (4.5 kgf·m, 33 lbf·ft)**

Fill with recommended oil to the upper level mark of the oil level dipstick (page 3-3).

Tighten the oil filler cap and install the oil level dipstick securely.

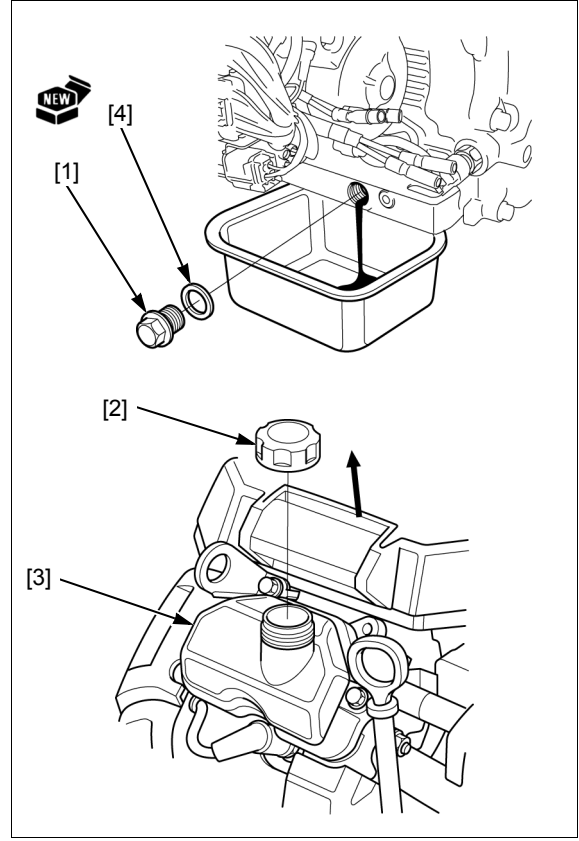

## OIL FILTER REPLACEMENT

Drain the engine oil (page 3-4).

Remove the oil filter [1] using the special tool.

### TOOLS:

**Oil filter wrench 64 mm [2] 07HAA-PJ70101**

Apply a light coat of engine oil to the O-ring [3] of the new oil filter.

Install the new oil filter and tighten to the specified torque.

**TORQUE: 12 N·m (1.2 kgf·m, 9.0 lbf·ft)**

Fill with recommended oil to the upper level mark of the oil level dipstick (page 3-3).

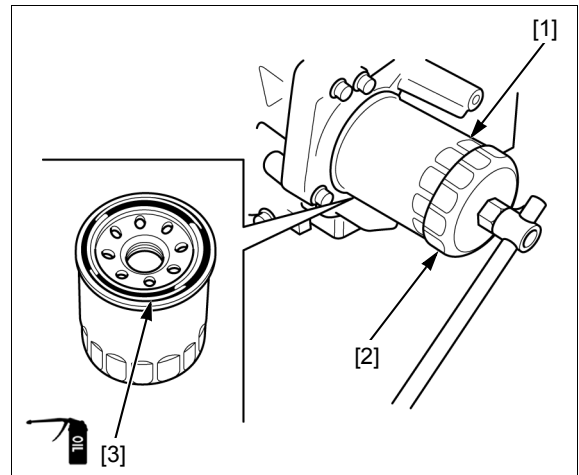

## AIR CLEANER CHECK/CLEANING

A dirty air filter will restrict air flow to the throttle body, reducing engine performance. If the engine is operated in dusty areas, clean the air cleaner more often than specified in the MAINTENANCE SCHEDULE.

### NOTICE

*Operating the engine without the air filters or with the filter installed loosely will allow dirt to enter the engine, causing rapid engine wear. Install the air filters securely.*

Remove the air cleaner cover [1].

Remove the wing nut [2] and air filter assembly [3]/[4].

Separate the air filters into the inner filter (Paper) [3] and the outer filter (Foam) [4]. Carefully check both filters for holes or tears and replace if damaged.

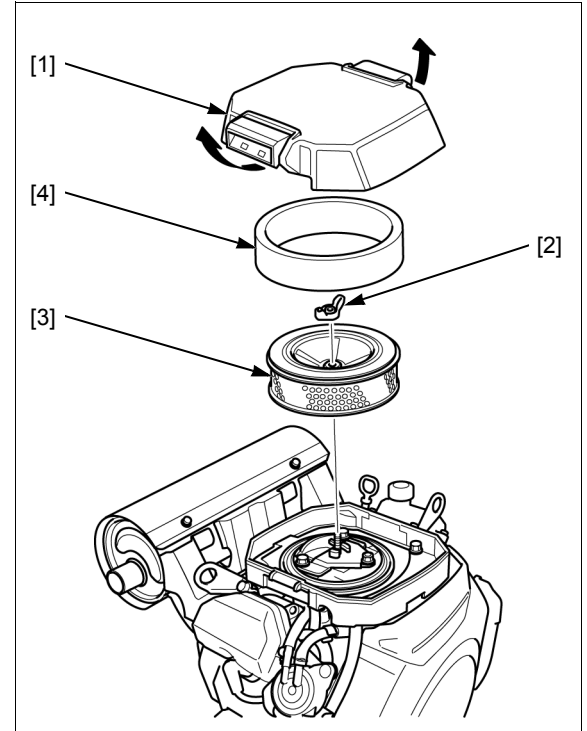

Clean the outer filter [1] in warm soapy water [2], rinse and allow to dry thoroughly, or clean with a non-flammable solvent and allow to dry thoroughly. Dip the filter in clean engine oil [3] and squeeze out all the excess oil. Excess oil will restrict air flow through the foam element and may cause the engine to smoke at startup.

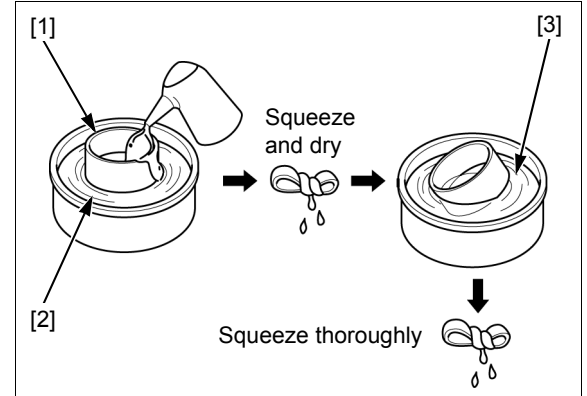

Tap the inner filter [1] lightly several times on a hard surface to remove excess dirt or blow compressed air lightly (207 kPa (2.11 kgf/cm<sup>2</sup>, 30 psi) or less) through the paper filter from the inside out. Never try to brush the dirt off; brushing will force dirt into the fibers.

Wipe dirt from the inside of the air cleaner case and the air cleaner cover, using a rag.

Check the air cleaner case packing for deterioration or damage. Make sure the air cleaner packing installed securely.

Attach the outer filter on the inner filter, and then install the air filter assembly and tighten the wing nut securely.

**TORQUE: 0.8 N·m (0.1 kgf·m, 0.6 lbf·ft)**

Install the air cleaner cover.

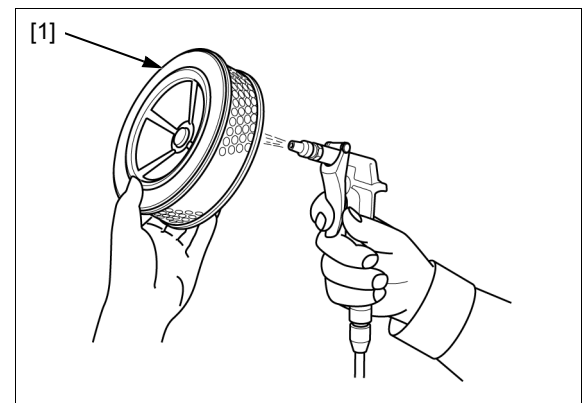



## MAINTENANCE

### AIR CLEANER REPLACEMENT

Remove the air cleaner filters ([page 3-5](#)).

Wipe dirt from the inside of the air cleaner case and the air cleaner cover, using a rag.

Check the air cleaner case packing for deterioration or damage. Make sure the air cleaner packing installed securely.

Install new air cleaner filters and tighten the wing nut securely.

**TORQUE: 0.8 N·m (0.1 kgf·m, 0.6 lbf·ft)**

Install the air cleaner cover.

### SPARK PLUG CHECK/ADJUSTMENT

#### ⚠ CAUTION

If the engine has been running, the engine will be very hot. Allow it to cool before proceeding.

Remove the spark plug cap [1], and then remove the spark plug [2] using a spark plug wrench [3].

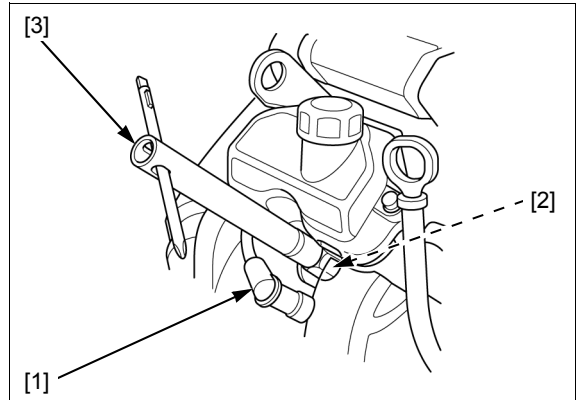

Visually check the spark plug. Replace the plug if the insulator [1] is cracked or chipped.

Check the sealing washer [2] for damage.

Replace the spark plug if the sealing washer is damaged ([page 3-7](#)).

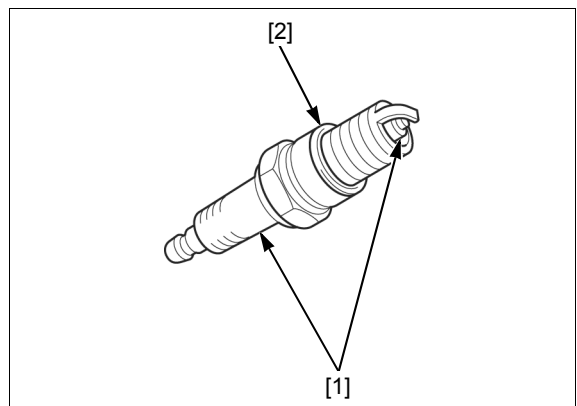

Measure the plug gap with a wire-type feeler gauge. If the measurement is out of the specification, adjust by bending the side electrode.

**PLUG GAP:** 0.7 – 0.8 mm (0.028 – 0.031 in)

Install the spark plug finger-tight to seat the washer, and then tighten it to the specified torque.

**TORQUE:** 18 N·m (1.8 kgf·m, 13.3 lbf·ft)

**NOTICE**

*A loose spark plug can become very hot and can damage the engine. Overtightening can damage the threads in the cylinder block.*

Install the spark plug cap securely.

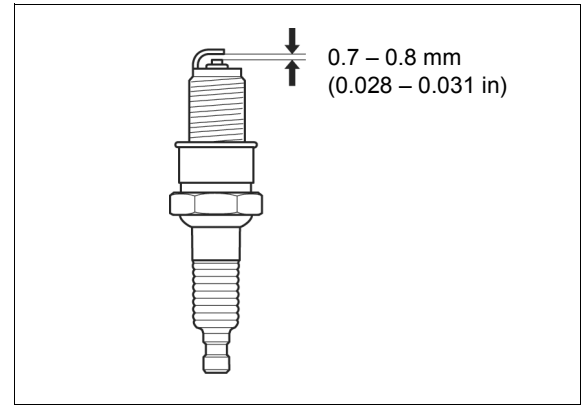

## SPARK PLUG REPLACEMENT

**⚠ CAUTION**

If the engine has been running, the engine will be very hot. Allow it to cool before proceeding.

Remove the spark plug ([page 3-6](#)).

Verify the new spark plug gap is correct ([page 3-6](#)).

Install the spark plug finger-tight to seat the washer, and then tighten it to the specified torque.

**SPARK PLUG:** BPR5ES (NGK)

**TORQUE:** 18 N·m (1.8 kgf·m, 13.3 lbf·ft)

**NOTICE**

*A loose spark plug can become very hot and can damage the engine. Overtightening can damage the threads in the cylinder block.*

Install the spark plug cap securely.

## SPARK ARRESTER CLEANING

### ⚠ CAUTION

The muffler becomes very hot during operation and remains hot for a while after stopping the engine. Be careful not to touch the muffler while it is hot. Allow it to cool before proceeding.

Remove the 5 x 8 mm tapping screw [1] and spark arrester [2].

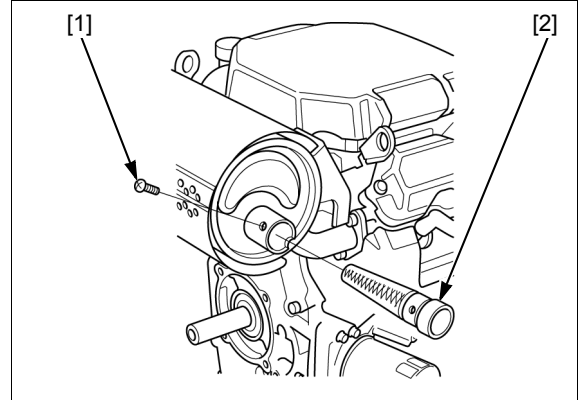

Clean the carbon deposits from the spark arrester screen [1] with a wire brush.

Check the spark arrester screen for damage. If the screen is damaged, replace the spark arrester.

Reinstall the spark arrester to the muffler.

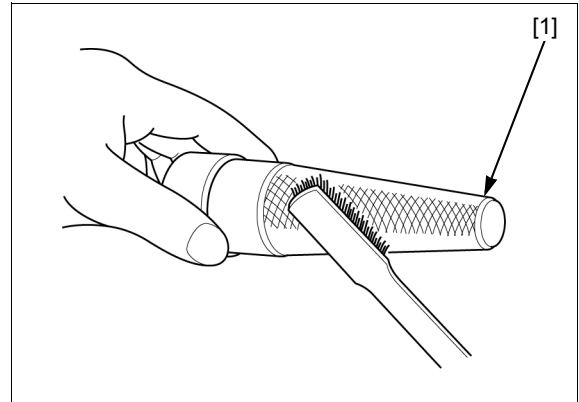

## VALVE CLEARANCE CHECK/ ADJUSTMENT

Remove the four flange bolts [1] and each head cover [2].

Remove the fan cover protector or screen grid ([page 5-2](#)).

Disconnect the spark plug caps [3] from the spark plugs.

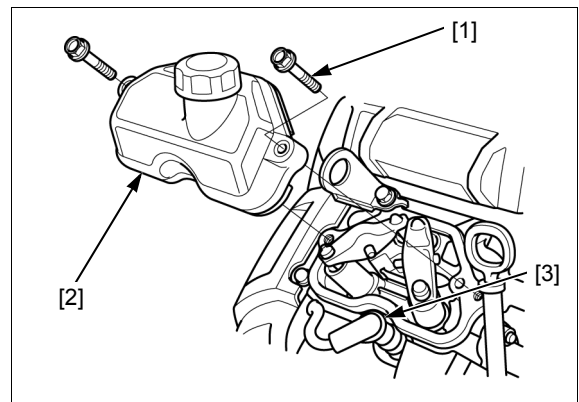

Set the piston of the No.1 cylinder at the top dead center of the compression stroke (both valves fully closed) by rotating the flywheel [1] clockwise slowly. When the No.1 piston is at the top dead center of the compression stroke, the "T" mark [2] on the cooling fan will align with the right side alignment mark [3] on the fan cover.

If the exhaust valve is opened, rotate the flywheel and align the "T" mark on the cooling fan with the alignment mark on the fan cover again.

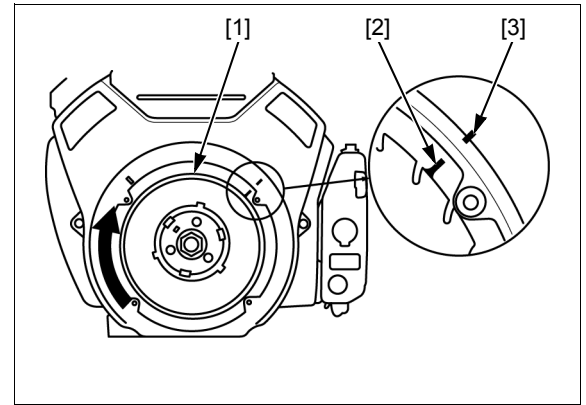

Insert a feeler gauge between the valve rocker arm [1] and valve stem [2] to measure the valve clearance.

**VALVE CLEARANCE:**

**IN: 0.18 – 0.22 mm (0.007 – 0.009 in)**

**EX: 0.18 – 0.22 mm (0.007 – 0.009 in)**

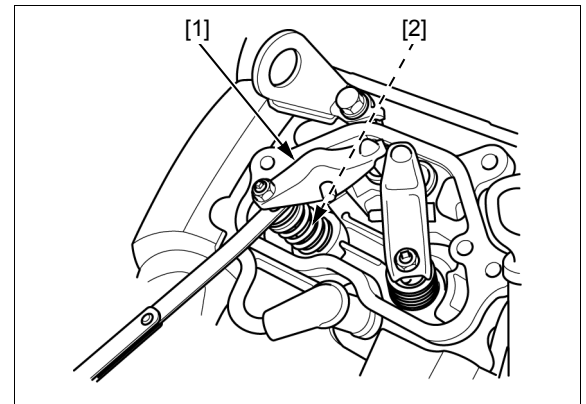

Set the piston of the No.2 cylinder at the top dead center of the compression stroke (both valves fully closed) by rotating the flywheel [1] 270 degrees clockwise slowly. When the No.2 piston is at the top dead center of the compression stroke, the "T" mark [2] on the cooling fan will align with the left side alignment mark [3] on the fan cover.

Insert a feeler gauge between the valve rocker arm and valve stem to measure the valve clearance.

**VALVE CLEARANCE:**

**IN: 0.18 – 0.22 mm (0.007 – 0.009 in)**

**EX: 0.18 – 0.22 mm (0.007 – 0.009 in)**

If adjustment is necessary, proceed as follows.

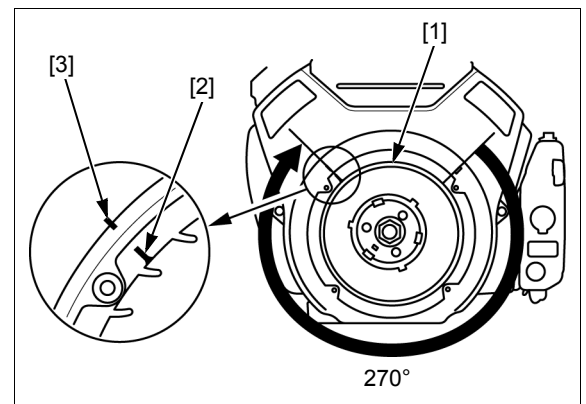

## MAINTENANCE

Hold the tappet adjusting screw [1] and loosen the tappet adjusting nut [2].

### TOOL:

**Tappet adjusting wrench 3 mm [3] 07908-KE90200**

Turn the tappet adjusting screw to obtain the specified clearance.

### VALVE CLEARANCE:

**IN: 0.18 – 0.22 mm (0.007 – 0.009 in)**

**EX: 0.18 – 0.22 mm (0.007 – 0.009 in)**

Hold the tappet adjusting screw and retighten the tappet adjusting nut to the specified torque.

**TORQUE: 7.5 N·m (0.8 kgf·m, 5.5 lbf·ft)**

Recheck the valve clearance, and if necessary, readjust the clearance.

Check the head cover packing for damage or deterioration and install it on the head cover. Attach the cylinder head cover to the cylinder and tighten the flange bolts securely.

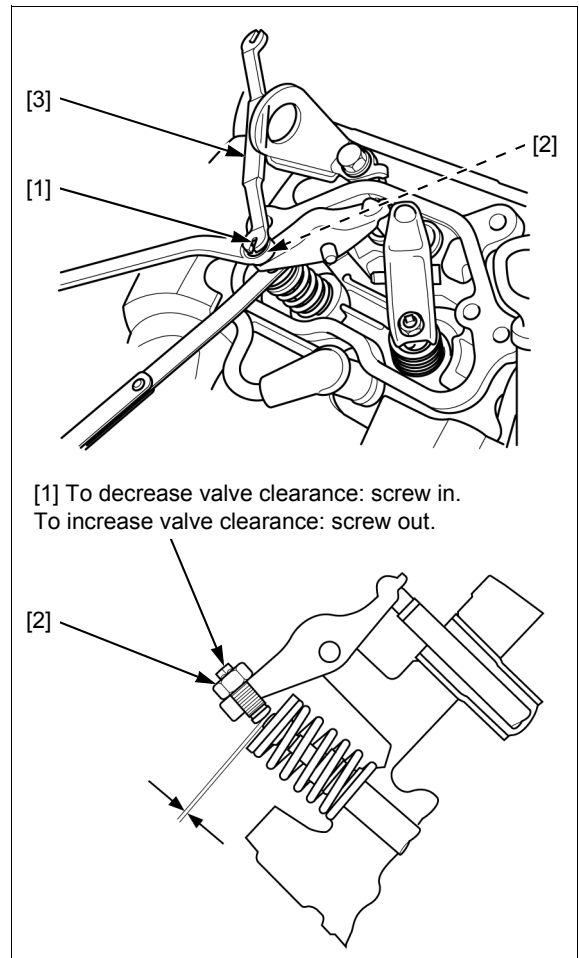

## COMBUSTION CHAMBER CLEANING

Remove the cylinder ([page 13-2](#)).

Prepare a cylinder of a thick paper or equivalent material [1], which diameter is as large as to fit against the inner wall of the cylinder, and insert the paper into the cylinder.

Attach the commercially available cleaning brush [2] to an electric drill and clean any carbon deposits from the combustion chamber.

**TOOL (commercially available):**

**Cleaning brush**

### NOTICE

- Do not remove valves from the cylinder while cleaning the combustion chamber.
- Be sure to insert a thick paper into the cylinder to protect the inner wall of the cylinder during clearing of the combustion chamber.
- Do not press the cleaning brush with force against the combustion chamber.

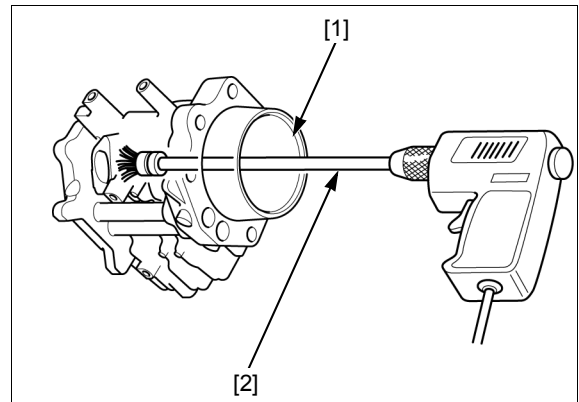

## FUEL FILTER REPLACEMENT

### ⚠ WARNING

Gasoline is highly flammable and explosive. You can be burned or seriously injured when handling fuel.

- Keep heat, sparks and flame away.
- Handle fuel only outdoors.
- Wipe up spills immediately.

Check the fuel filter [1] for water accumulation or sediment. If necessary replace it.

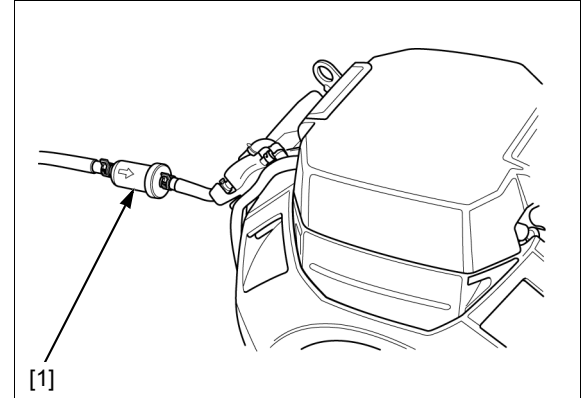

Install the commercially available tube clamps (HCP6) [1] on the fuel tubes [2] on both sides of the fuel filter [3].

Disconnect the fuel tubes from the fuel filter to remove the fuel filter.

Install a new fuel filter with the arrow mark toward the fuel pump (low pressure side) side.

Check the connecting parts for any sign of fuel leakage.

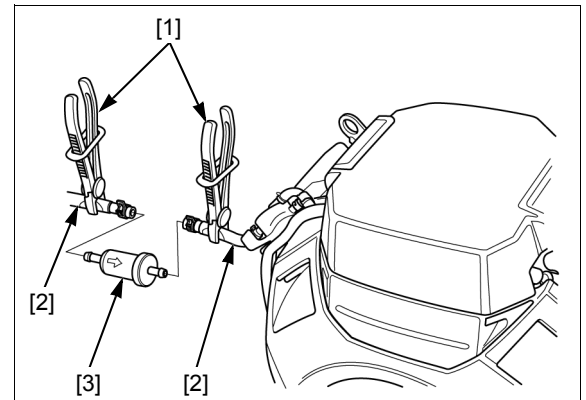

## FUEL TUBE CHECK

### ⚠ WARNING

Gasoline is highly flammable and explosive. You can be burned or seriously injured when handling fuel.

- Keep heat, sparks and flame away.
- Handle fuel only outdoors.
- Wipe up spills immediately.

Remove the air cleaner case ([page 6-12](#)).

Check the fuel tube for deterioration, cracks or signs of leakage. If necessary replace it.

Install the air cleaner case ([page 6-12](#)).

---

**MEMO**

---

BEFORE TROUBLESHOOTING.....	4-2	DTC INDEX .....	4-7
TROUBLESHOOTING.....	4-3	DTC TROUBLESHOOTING .....	4-7



## TROUBLESHOOTING

---

### BEFORE TROUBLESHOOTING

- Use a known-good battery for troubleshooting.
- Check that the connectors are connected securely.
- Check there is sufficient fresh fuel in the fuel tank.
- Read the circuit tester's operation instructions carefully, and observe the instructions during inspection.
- Disconnect the battery cable before continuity inspection.

---

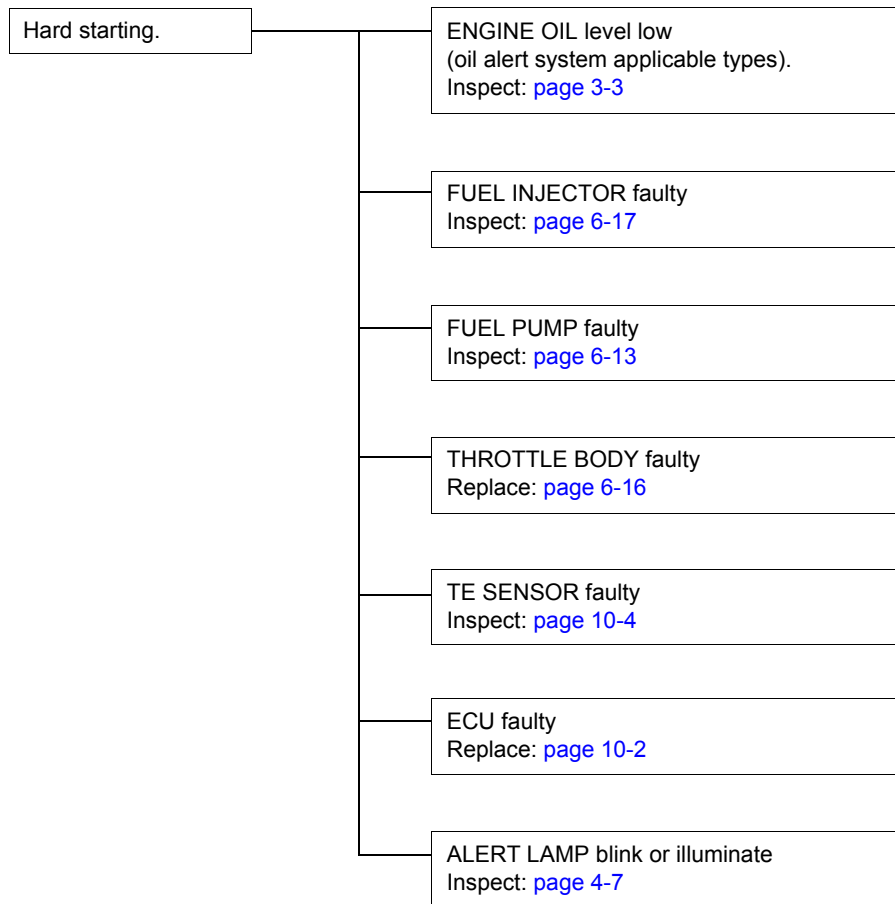
**TROUBLESHOOTING****GENERAL SYMPTOMS AND POSSIBLE CAUSES**

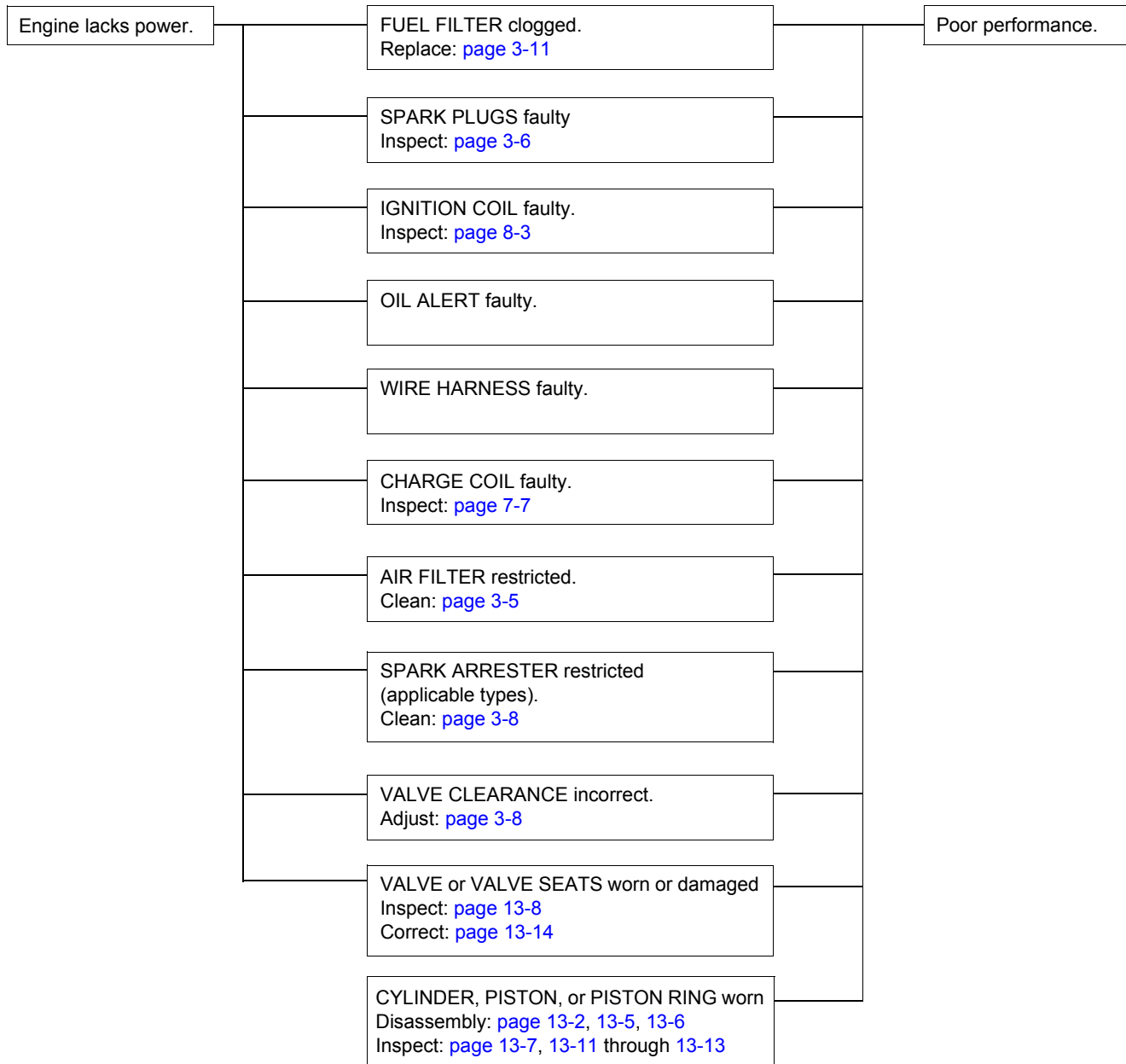

**HARD STARTING**

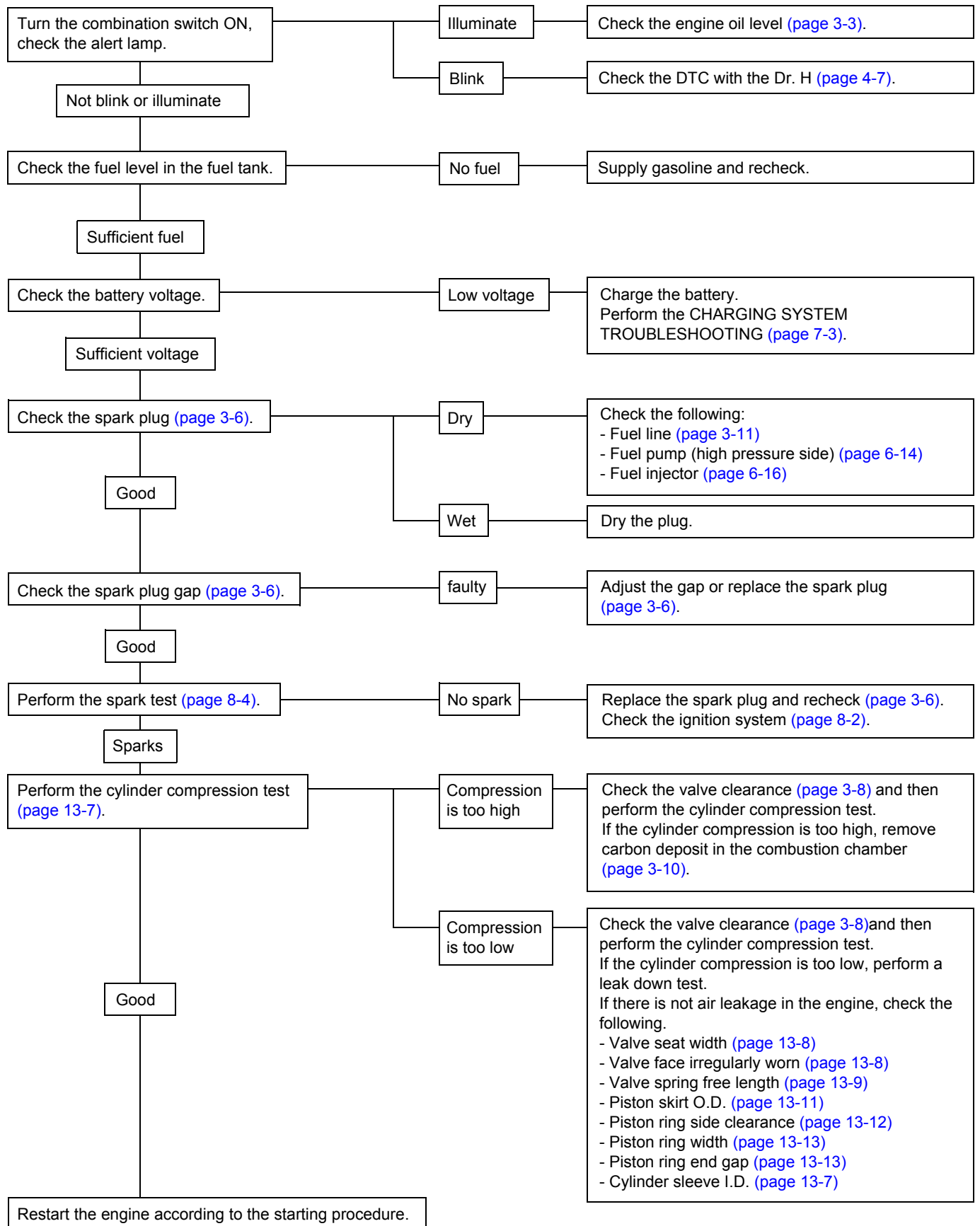

# TROUBLESHOOTING

## TROUBLESHOOT PROCEDURE

- When the ECU detects an abnormality in the system, it turns on the warning indicator. Troubleshoot the system according to the number of DTC (Diagnostic Trouble Code).

Proceed in the sequence as follows:

1. Turn the combination switch OFF if indicator come on or blink.
2. Turn the combination switch ON and check that the indicators come on and go off after 0.5 second. If the indicators operate normally, the system is normal and the failure will be intermittent.
  - DTC troubleshooting index to troubleshoot in accordance with the DTC (page 4-7) (Dr. H is required)

## How to Use the Dr. H

Refer to the Instruction Manual for the Dr. H for the connection method to a personal computer and for the set-up method.

1. Turn the combination switch OFF.
2. Remove the dummy connector [1] from the DLC.
3. Connect the 4P connector [2] of Dr. H [3] to DLC.

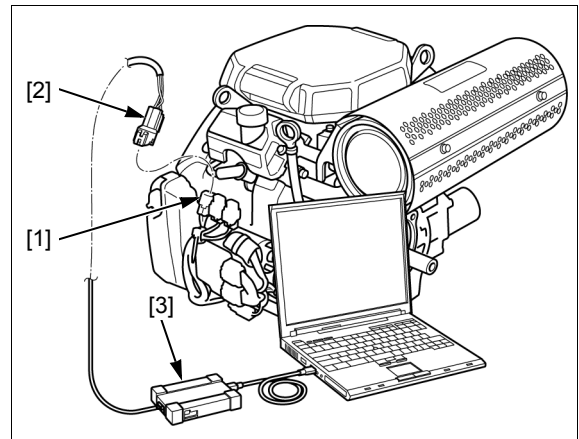

## INSPECTION AT ECU CONNECTOR

- Always clean around and keep any foreign material away from the ECU connector [1] before disconnecting it.
- A faulty fuel injection system is often related to poorly connected or corroded terminals. Check those connections before proceeding.
- In testing at the ECU connector (wire harness side) terminal, always use the test probe. Insert the test probe into the connector terminal, and then attach the digital multimeter probe to the test probe.

**TOOL:**

**Test probe [2]**

**07ZAJ-RDJA110**

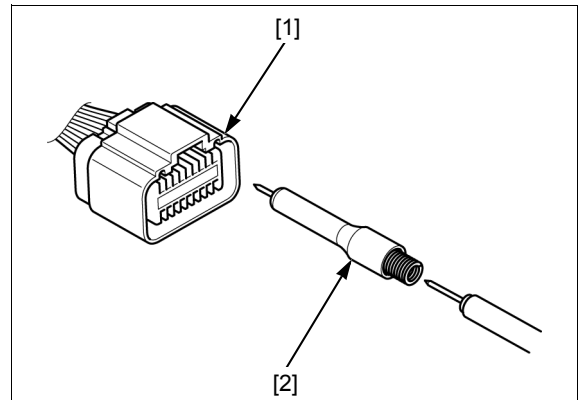

## DTC INDEX

DTC	INDICATOR	FUNCTION FAILURE	Refer to page
0-1	9 Blinks	ECU malfunction	4-7
1-1	2 Blinks	Throttle motor malfunction	4-7
2-1	3 Blinks	TPS 1 malfunction	4-9
3-1	4 Blinks	TPS 2 malfunction	4-10
4-1	5 Blinks	TPS malfunction	4-12
5-1	6 Blinks	IAT sensor malfunction	4-13
6-1	7 Blinks	TE sensor malfunction	4-14
7-1	8 Blinks	MAP sensor malfunction	4-15

## DTC TROUBLESHOOTING

**DTC 0-1 (ECU MALFUNCTION)**

Replace the ECU with a known good one (page 10-2), and recheck.

**DTC 1-1 (THROTTLE MOTOR MALFUNCTION)****1. Throttle Valve and Return Spring Inspection**

NOTE:

- Be careful not to damage the throttle valve.
- The return spring cannot be replaced. If the return spring is faulty, replace the throttle body assembly.

Remove the throttle body (page 6-16).

Open the throttle valve [1] with your finger.

**Does the throttle valve open smoothly and return automatically?**

**YES** – GO TO STEP 2.

**NO** – Faulty throttle body (throttle valve and/or return spring)

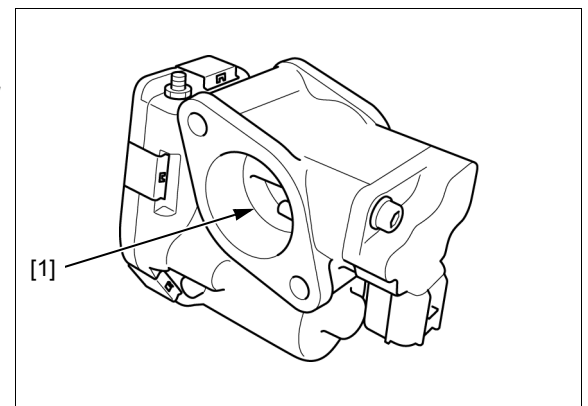
**2. Throttle Body Inspection**

Check the throttle bore [1] and valve visually for carbon deposits.

**Is there contamination?**

**YES** – Clean the throttle valve and bore carefully.

**NO** – GO TO STEP 3.

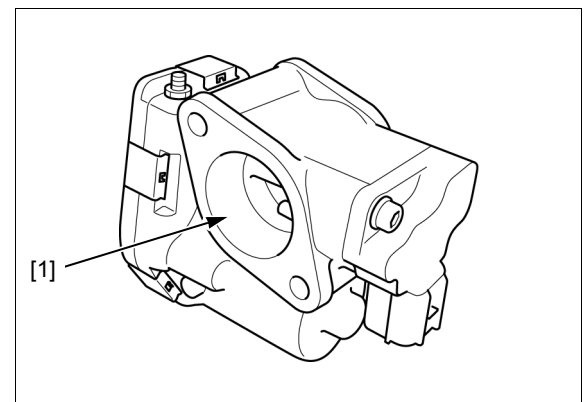

# TROUBLESHOOTING

## 3. System Inspection

Install the throttle body (page 6-16).

Start the engine and let it idle, and then stop the engine and wait 10 seconds.

Turn the combination switch ON.

**Does the indicator come on?**

**YES** – GO TO STEP 4.

**NO** – Intermittent failure

## 4. Motor Line Open Circuit Inspection

Turn the combination switch OFF.

Disconnect the throttle motor 2P connector (page 6-16).

Disconnect the ECU 18P (Gray) connector (page 10-2).

Check for continuity between the wire harness side 2P connector [1] and 18P (Gray) connector [2].

**TOOL:**

**Test probe** 07ZAJ-RDJA110

**Connection: Bu – 12**  
**G – 11**

**Is there continuity?**

**YES** – GO TO STEP 5.

**NO** – Open circuit in the Bu or G wire

## 5. Motor Inspection

NOTE:

- The motor cannot be replaced. If the motor is faulty, replace the throttle body assembly.

Replace the throttle body assembly (page 6-16).

Connect the ECU 18P (Gray) connector (page 10-2).

Start the engine and let it idle, and then stop the engine and wait 10 seconds.

**Does the indicator come on?**

**YES** – Replace the ECU with a known good one (page 10-2) and recheck.

**NO** – Faulty original throttle motor

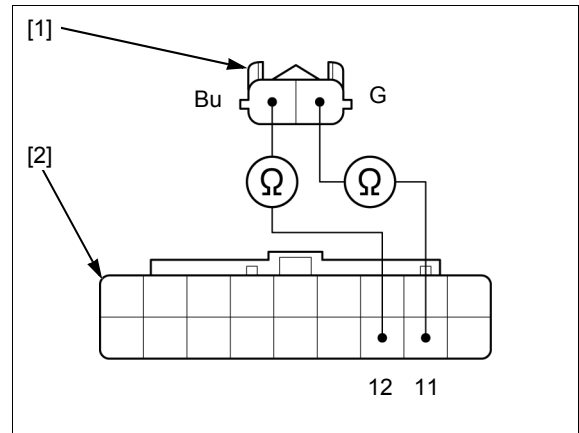

## DTC 2-1 (TP SENSOR 1 MALFUNCTION)

### NOTE:

- The MAP/IAT/TP sensor cannot be replaced. If the sensor is faulty, replace the throttle body assembly.

### 1. TP Sensor Input Voltage Inspection

Turn the combination switch OFF.

Disconnect the MAP/IAT/TP sensor 6P connector (page 6-16).

Turn the combination switch ON.

Measure the voltage at the wire harness side 6P connector [1].

**Connection: Br (+) – G (-)**

**Is the voltage within 4.9 – 5.1 V?**

**YES** – GO TO STEP 2.

**NO** – Open or short circuit in the Br or G wire

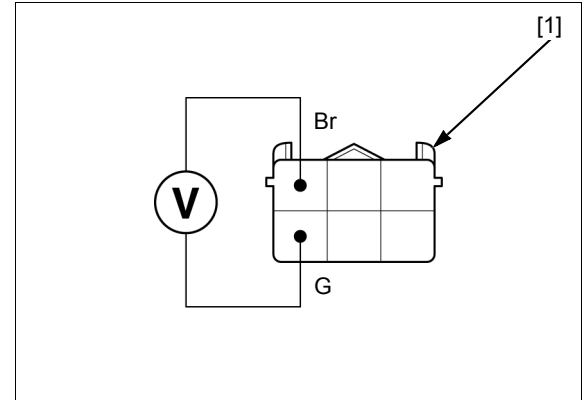

### 2. TP Sensor 1 Output Line Open Circuit Inspection

Turn the combination switch OFF.

Disconnect the ECU 18P (Gray) connector (page 10-2).

Check for continuity between the wire harness side 6P connector [1] and 18P connector [2].

**TOOL:**

**Test probe** 07ZAJ-RDJA110

**Connection: R/BI – 5**

**Is there continuity?**

**YES** – GO TO STEP 3.

**NO** – Open circuit in the R/BI wire

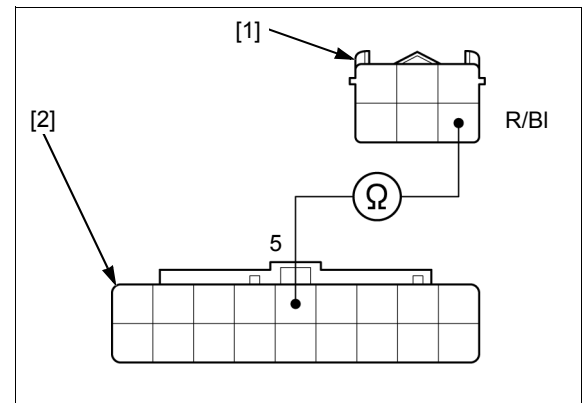

### 3. TP Sensor 1 Output Line Short Circuit Inspection

Check for continuity between the wire harness side 6P connector [1] and ground.

**Connection: R/BI – Ground**

**Is there continuity?**

**YES** – Short circuit in the R/BI wire

**NO** – GO TO STEP 4.

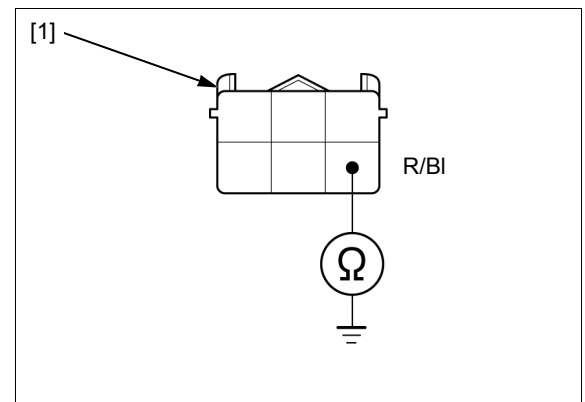



## TROUBLESHOOTING

### 4. TP Sensor 1 Inspection

Replace the throttle body assembly (page 6-16).

Connect the ECU 18P (Gray) connector (page 10-2).

Turn the combination switch ON.

Check the indicator.

#### **Does the indicator come on?**

**YES** – Replace the ECU with a known good one (page 10-2) and recheck.

**NO** – Faulty original TP sensor

## DTC 3-1 (TP SENSOR 2 MALFUNCTION)

### NOTE:

- The MAP/IAT/TP sensor cannot be replaced. If the sensor is faulty, replace the throttle body assembly.

### 1. TP Sensor Input Voltage Inspection

Turn the combination switch OFF.

Disconnect the MAP/IAT/TP sensor 6P connector (page 6-16).

Turn the combination switch ON.

Measure the voltage at the wire harness side 6P connector [1].

**Connection: Br (+) – G (-)**

**Is the voltage within 4.9 – 5.1 V?**

**YES** – GO TO STEP 2.

**NO** – Open or short circuit in the Br or G wire

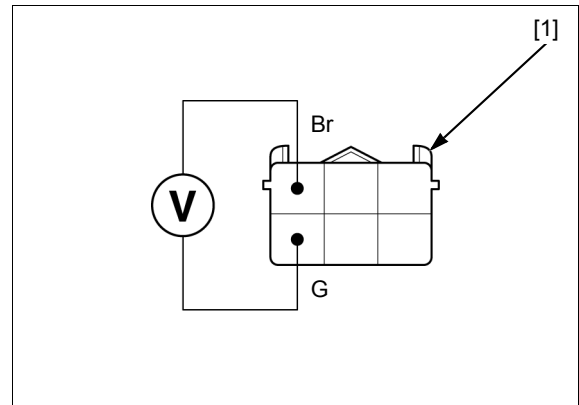

### 2. TP Sensor 2 Output Line Open Circuit Inspection

Turn the combination switch OFF.

Disconnect the ECU 18P (Black) connector (page 10-2).

Check for continuity between the wire harness side 6P connector [1] and 18P connector [2].

#### **TOOL:**

**Test probe** 07ZAJ-RDJA110

**Connection: G/R – 12**

**Is there continuity?**

**YES** – GO TO STEP 3.

**NO** – Open circuit in the G/R wire

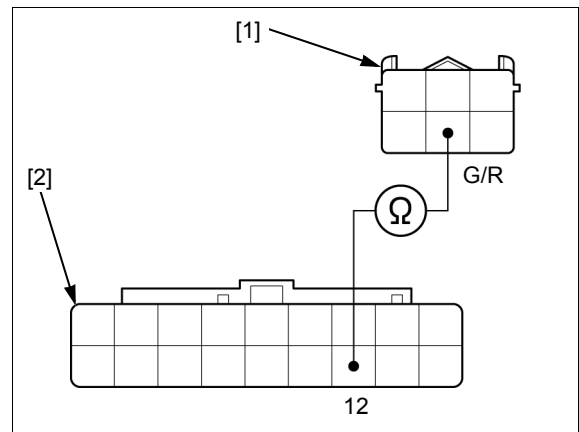

### 3. TP Sensor 2 Output Line Short Circuit Inspection

Check for continuity between the wire harness side 6P connector [1] and ground.

**Connection: G/R – Ground**

**Is there continuity?**

**YES** – Short circuit in the G/R wire

**NO** – GO TO STEP 4.

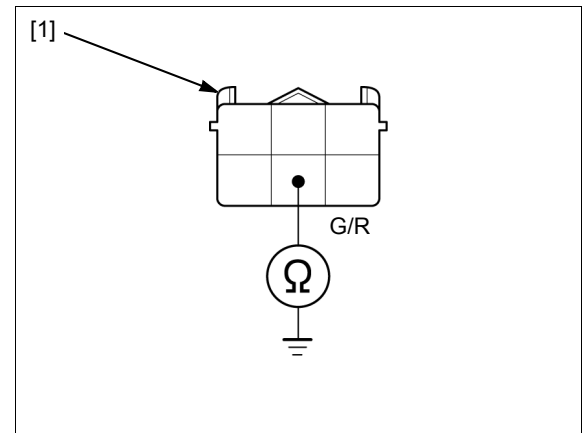

### 4. TP Sensor 2 Inspection

Replace the throttle body assembly ([page 6-16](#)).

Connect the ECU 18P (Black) connector ([page 10-2](#)).

Turn the combination switch ON.

Check the indicator.

**Does the indicator come on?**

**YES** – Replace the ECU with a known good one ([page 10-2](#)) and recheck.

**NO** – Faulty original TP sensor

## TROUBLESHOOTING

### DTC 4-1 (TP SENSOR 1 and 2 VOLTAGE CORRELATION MALFUNCTION/SHORT CIRCUIT)

NOTE:

- The MAP/IAT/TP sensor cannot be replaced. If the sensor is faulty, replace the throttle body assembly.

#### 1. Throttle Valve Operation Inspection

Turn the combination switch OFF.

Remove the elbow (page 6-16).

Turn the combination switch ON and check the throttle valve operation.

**Does the throttle valve operate normally?**

**YES** – GO TO STEP 2.

**NO** – Clean the throttle bores and valves carefully.

#### 2. TP Sensor Line Short Circuit Inspection

Turn the combination switch OFF.

Disconnect the ECU 18P (Gray) and (Black) connectors (page 10-2).

Disconnect the MAP/IAT/TP sensor 6P connector (page 6-16).

Check for continuity between the wire harness side 18P (Gray) connector [1] and 18P (Black) connector [2].

**TOOL:**

**Test probe** 07ZAJ-RDJA110

**Connection: 5 (Gray) – 12 (Black)**

**Is there continuity?**

**YES** – Short circuit in the R/BI wire-to-G/R wire

**NO** – GO TO STEP 3.

#### 3. TP Sensor Inspection

Replace the throttle body assembly (page 6-16).

Connect the ECU 18P connectors (page 10-2).

Turn the combination switch ON.

Check the indicator.

**Does the indicator come on?**

**YES** – Replace the ECU with a known good one (page 10-2) and recheck.

**NO** – Faulty original TP sensor

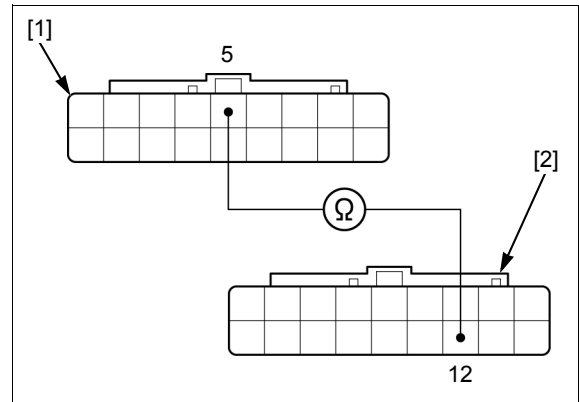

**DTC 5-1 (IAT SENSOR MALFUNCTION)****NOTE:**

- The MAP/IAT/TP sensor cannot be replaced. If the sensor is faulty, replace the throttle body assembly.

**1. IAT Sensor Line Open Circuit Inspection**

Disconnect the MAP/IAT/TP sensor 6P connector (page 6-16).

Disconnect the ECU 18P (Black) connector (page 10-2).

Check for continuity between the wire harness side 6P connector [1] and 18P connector [2].

**TOOL:**

**Test probe**

**07ZAJ-RDJA110**

**Connection: R/Y – 8**

**Is there continuity?**

**YES** – GO TO STEP 2.

**NO** – Open circuit in the R/Y wire

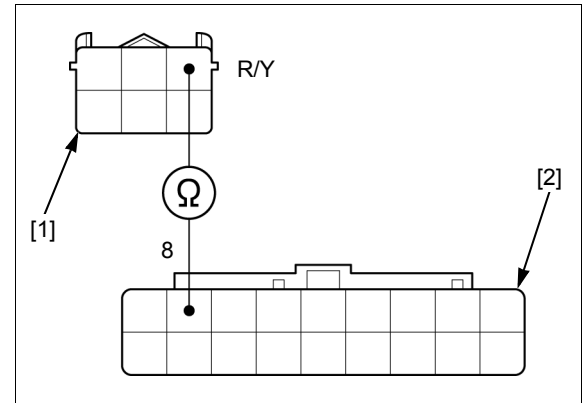
**2. IAT Sensor Output Line Short Circuit Inspection**

Check for continuity between the wire harness side 6P connector [1] and ground.

**Connection: R/Y – Ground**

**Is there continuity?**

**YES** – Short circuit in the R/Y wire

**NO** – GO TO STEP 3.

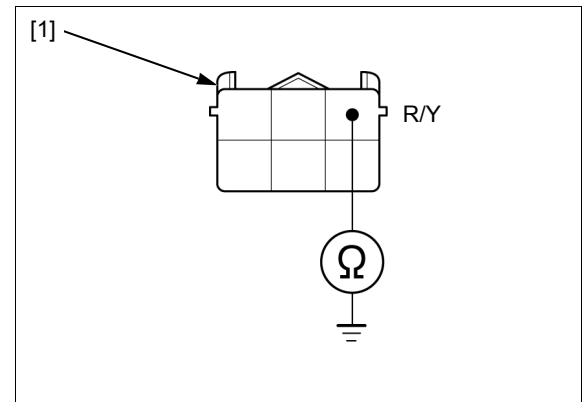
**3. IAT Sensor Ground Line Open Circuit Inspection**

Check for continuity between the wire harness side 6P connector [1] and 18P connector [2].

**Connection: G – 10**

**Is there continuity?**

**YES** – GO TO STEP 4.

**NO** – Open circuit in the G wire

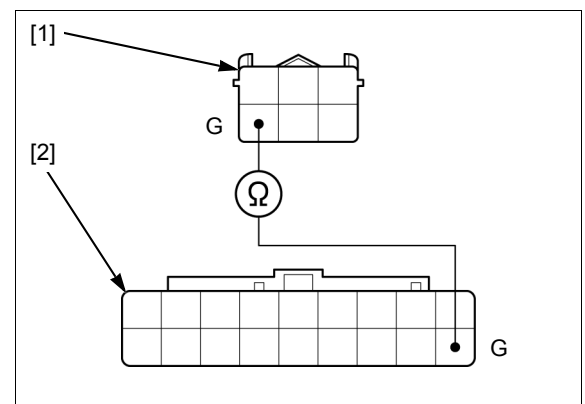

# TROUBLESHOOTING

## 4. IAT Sensor Inspection

Replace the throttle body assembly (page 6-16).

Connect the ECU 18P (Black) connector (page 10-2).

Turn the combination switch ON.

Check the indicator.

### **Does the indicator come on?**

**YES** – Replace the ECU with a known good one (page 10-2) and recheck.

**NO** – Faulty original IAT sensor

## DTC 6-1 (TE SENSOR MALFUNCTION)

### 1. TE Sensor Output Line Open Circuit Inspection

Turn the combination switch OFF.

Disconnect the TE sensor 2P connector (page 10-4).

Disconnect the ECU 18P (Black) connector (page 10-2).

Check for continuity between the wire harness side 2P connector [1] and 18P connector [2].

#### **TOOL:**

**Test probe** 07ZAJ-RDJA110

**Connection: R/Y – 14**

#### **Is there continuity?**

**YES** – GO TO STEP 2.

**NO** – Open circuit in the R/Y wire

### 2. TE Sensor Output Line Short Circuit Inspection

Check for continuity between the wire harness side 2P connector [1] and ground.

**Connection: R/Y – Ground**

#### **Is there continuity?**

**YES** – Short circuit in the R/Y wire

**NO** – GO TO STEP 3.

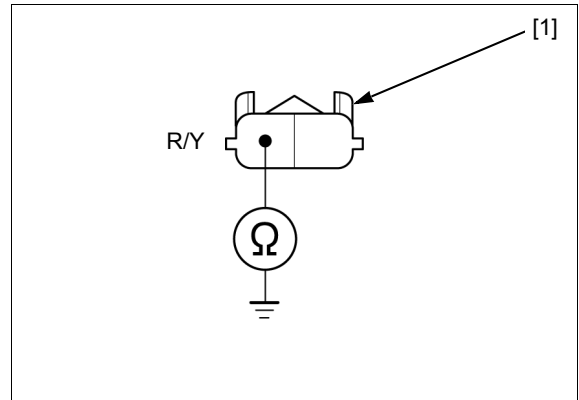
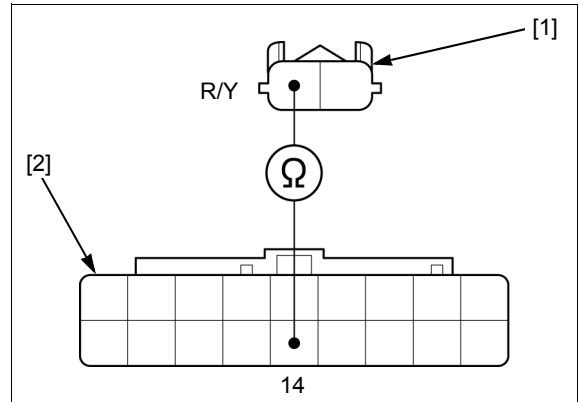

**3. TE Sensor Ground Line Open Circuit Inspection**

Check for continuity between the wire harness side 2P connector [1] and 18P connector [2].

**Connection: G – 10**

**Is there continuity?**

**YES** – GO TO STEP 4.

**NO** – Open circuit in the G wire

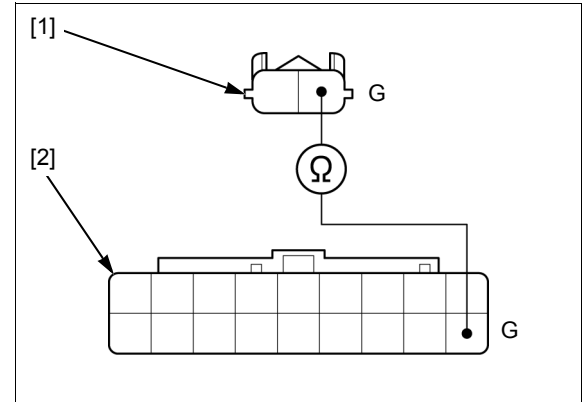

**4. TE Sensor Inspection**

Replace the TE sensor ([page 10-4](#)).

Connect the ECU 18P (Black) connector ([page 10-2](#)).

Turn the combination switch ON.

Check the indicator.

**Does the indicator come on?**

**YES** – Replace the ECU with a known good one ([page 10-2](#)) and recheck.

**NO** – Faulty original TE sensor

**DTC 7-1 (MAP SENSOR MALFUNCTION)**

NOTE:

- The MAP/IAT/TP sensor cannot be replaced. If the sensor is faulty, replace the throttle body assembly.

**1. MAP Sensor Input Voltage Inspection**

Turn the combination switch OFF.

Disconnect the MAP/IAT/TP sensor 6P connector ([page 6-16](#)).

Turn the combination switch ON.

Measure the voltage at the wire harness side 6P connector [1].

**Connection: Br (+) – G (-)**

**Is the voltage within 4.9 – 5.1 V?**

**YES** – GO TO STEP 2.

**NO** – Open or short circuit in the Br or G wire

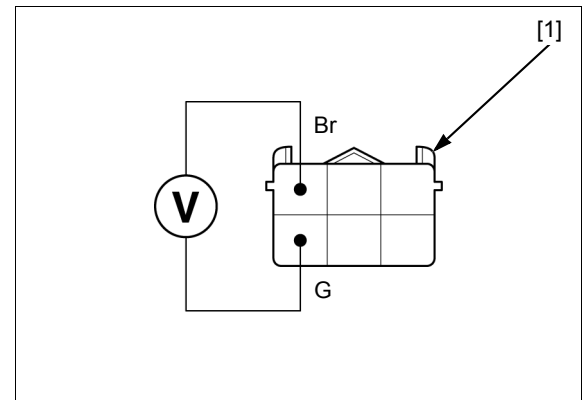

## TROUBLESHOOTING

### 2. MAP Sensor Output Line Open Circuit Inspection

Turn the combination switch OFF.

Disconnect the ECU 18P (Black) connector  
([page 10-2](#)).

Check for continuity between the wire harness side  
6P connector [1] and 18P connector [2].

**TOOL:**

**Test probe** 07ZAJ-RDJA110

**Connection: W/R – 11**

**Is there continuity?**

**YES** – GO TO STEP 3.

**NO** – Open circuit in the W/R wire

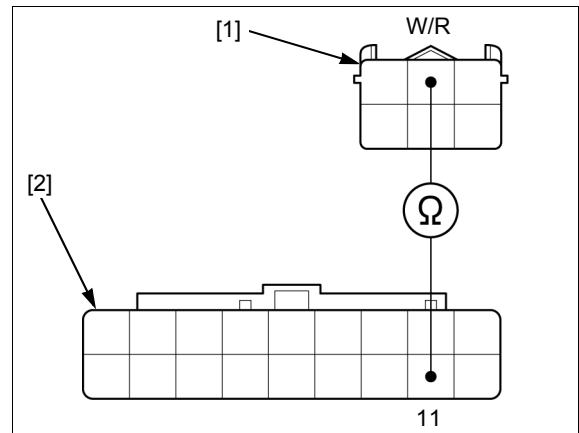

### 3. MAP Sensor Output Line Short Circuit Inspection

Check for continuity between the wire harness side  
6P connector [1] and ground.

**Connection: W/R – Ground**

**Is there continuity?**

**YES** – Short circuit in the W/R wire

**NO** – GO TO STEP 4.

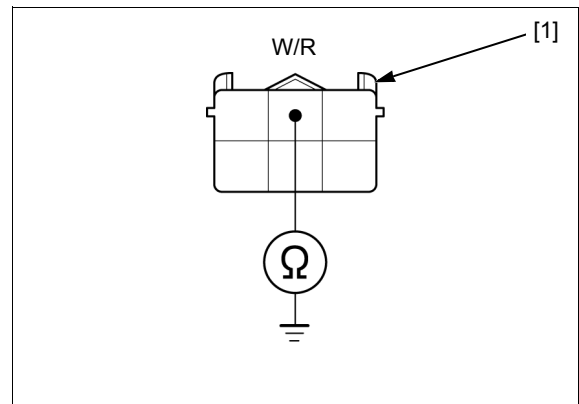

### 4. MAP Sensor Inspection

Replace the throttle body assembly ([page 6-16](#)).

Connect the ECU 18P (Black) connector  
([page 10-2](#)).

Turn the combination switch ON.

Check the indicator.

**Does the indicator come on?**

**YES** – Replace the ECU with a known good one  
([page 10-2](#)) and recheck.

**NO** – Faulty original MAP sensor

FAN COVER .....5-2

LOWER SHROUD .....5-3



**COVER**

**FAN COVER**

**REMOVAL/INSTALLATION**

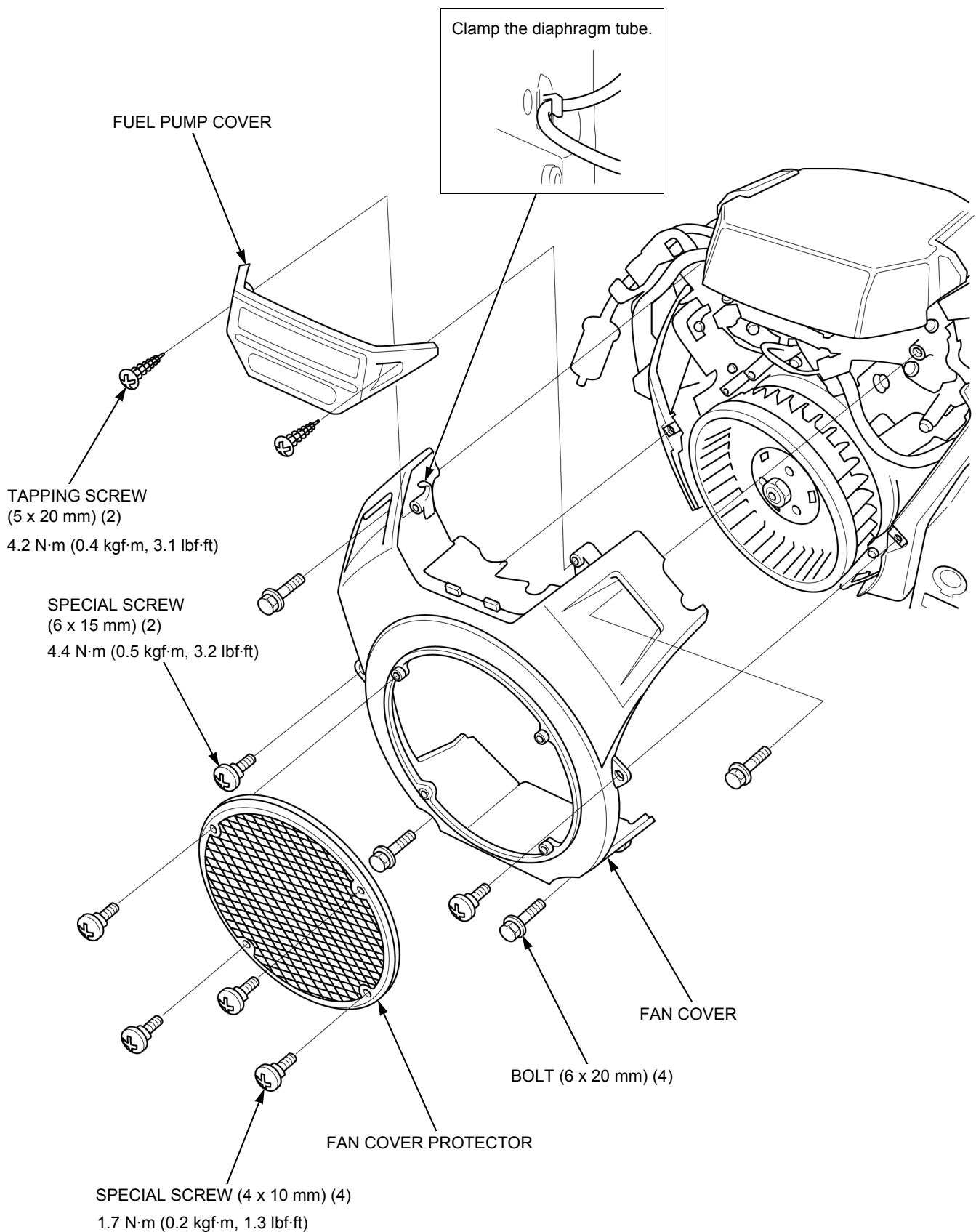

## LOWER SHROUD

### REMOVAL/INSTALLATION

Remove the fan cover (page 5-2).

Remove the fuel pump (high pressure side) (page 6-14).

#### L. LOWER SHROUD

GX800IRH: Remove the oil cooler (page 12-6).

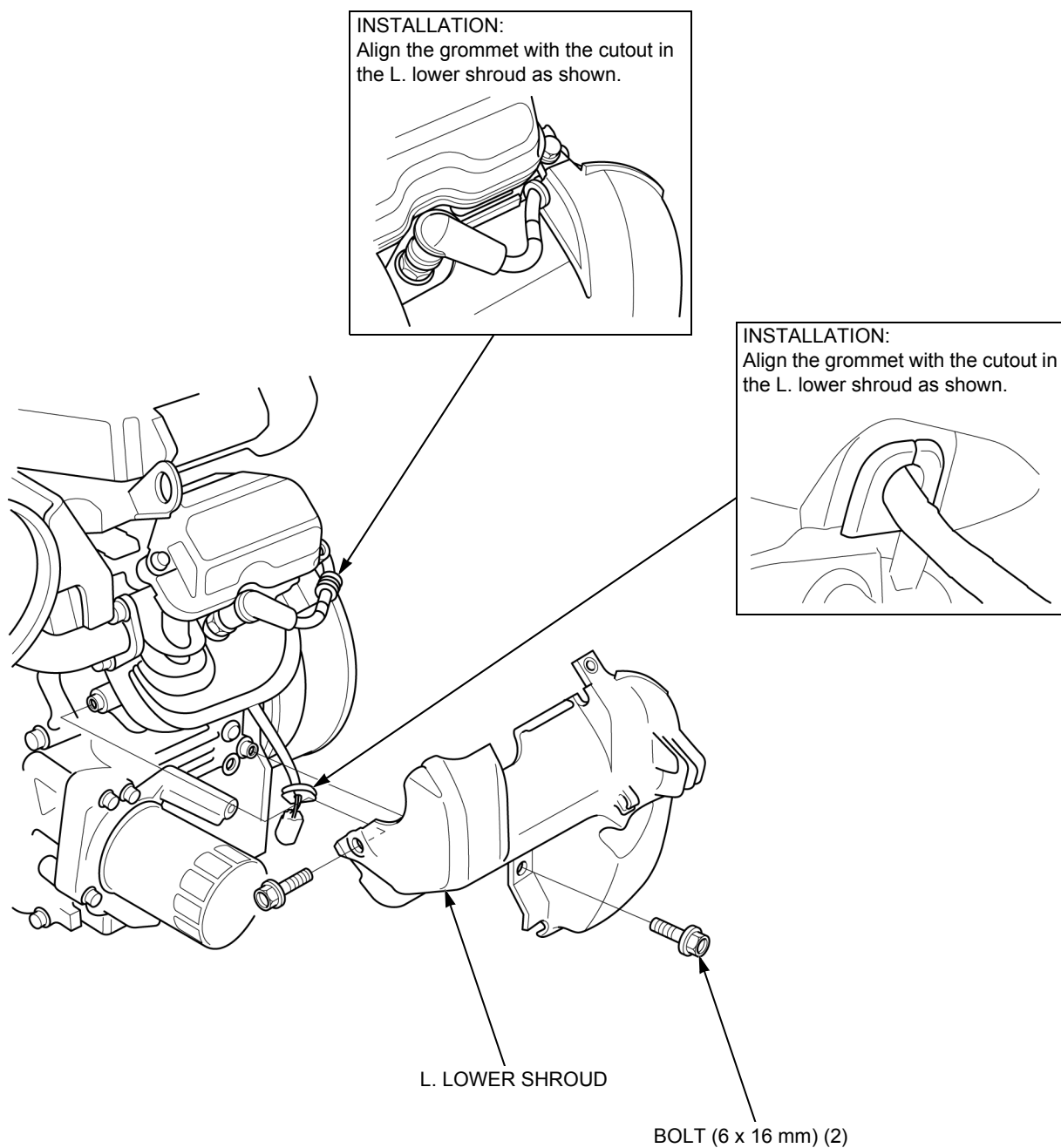

# COVER

## R. LOWER SHROUD

Remove the control box (page 12-6).

### HIGH TENSION CORD GROMMET

#### INSTALLATION:

Align the grommet with the cutout in the R. lower shroud as shown.

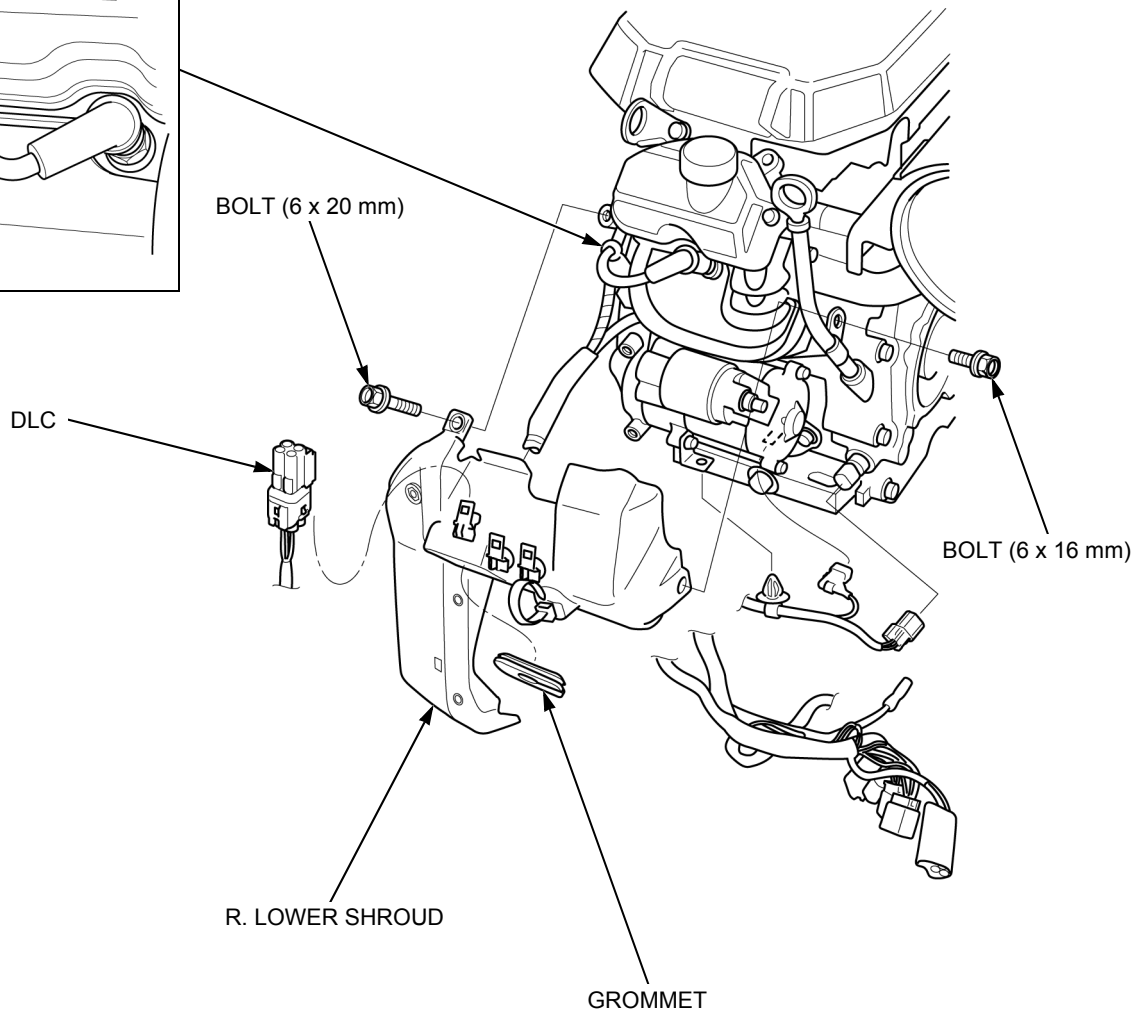
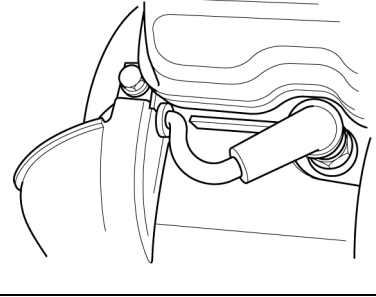

<b>SYSTEM DIAGRAM .....</b>	<b>6-2</b>	<b>FUEL PUMP (LOW PRESSURE SIDE) .....</b>	<b>6-13</b>
<b>TROUBLESHOOTING.....</b>	<b>6-3</b>	<b>FUEL PUMP (HIGH PRESSURE SIDE) .....</b>	<b>6-14</b>
<b>FUEL LINE INSPECTION.....</b>	<b>6-6</b>	<b>CAULKING CLAMP .....</b>	<b>6-15</b>
<b>AIR CLEANER.....</b>	<b>6-12</b>	<b>THROTTLE BODY/INLET MANIFOLD/ FUEL INJECTOR .....</b>	<b>6-16</b>

# FUEL SYSTEM

## SYSTEM DIAGRAM

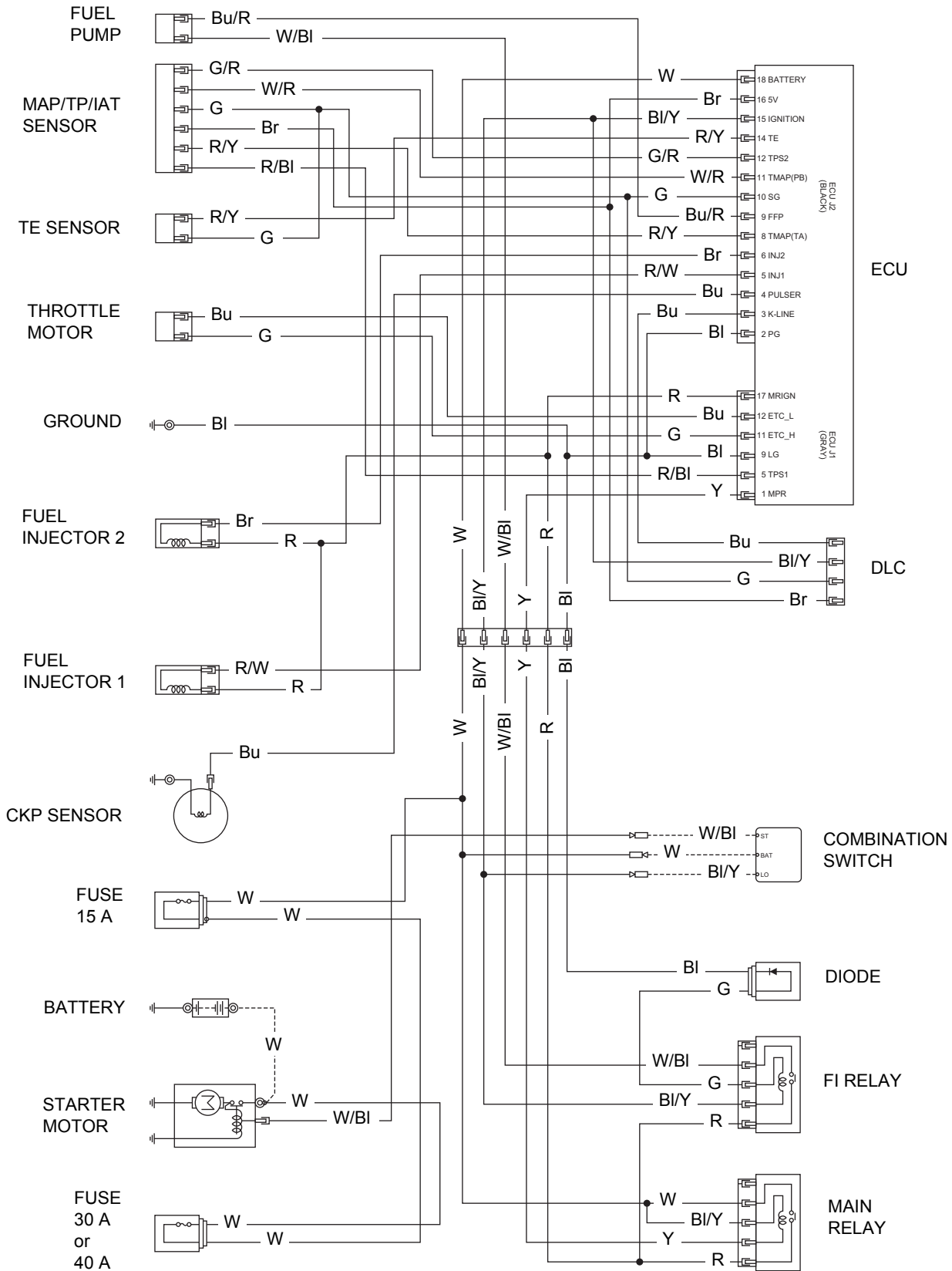

# TROUBLESHOOTING

## HARD STARTING

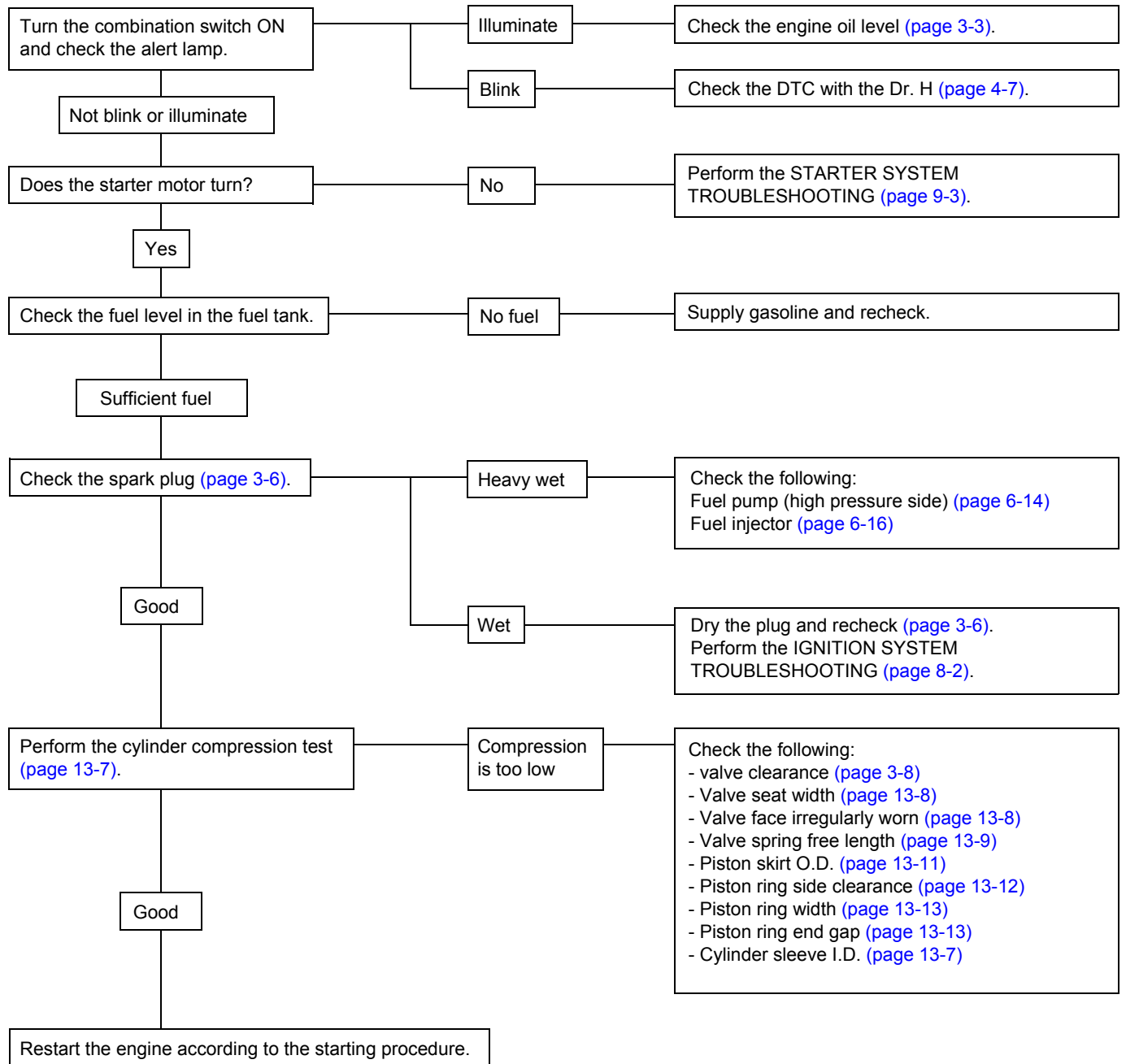

## FUEL SYSTEM

### ENGINE ROTATION MALFUNCTION

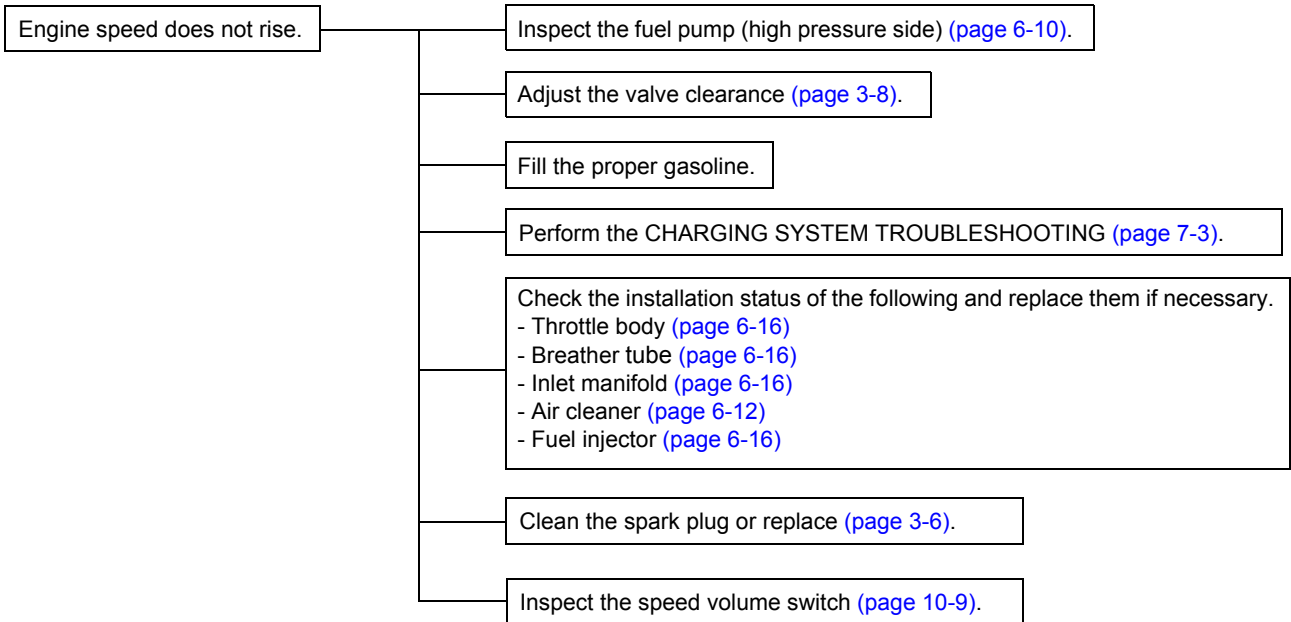
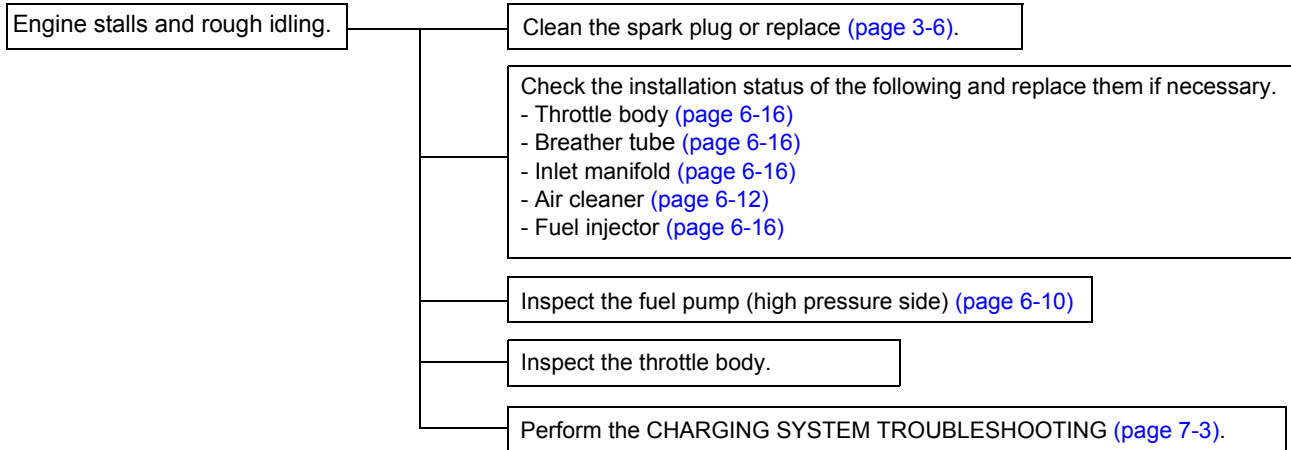

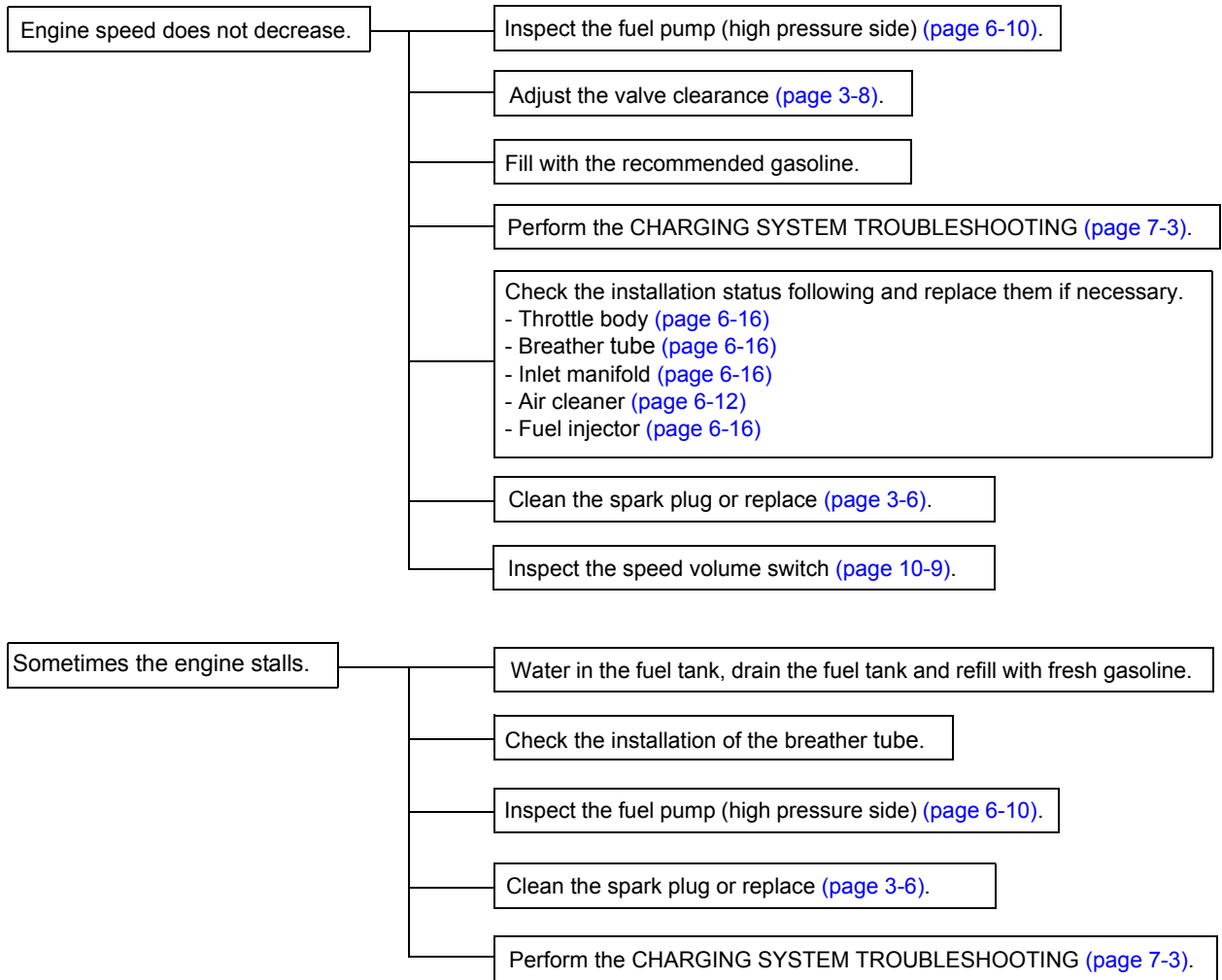



## FUEL LINE INSPECTION

### FUEL PRESSURE RELIEVING

NOTE:

- Before disconnecting the fuel hose, relieve pressure from the system as follows.
1. Turn the combination switch OFF.
  2. Disconnect the fuel pump (high pressure side) 2P connector [1].
  3. Start the engine, and let it idle until the engine stalls.
  4. Turn the combination switch OFF.
  5. Disconnect the battery negative (-) cable.

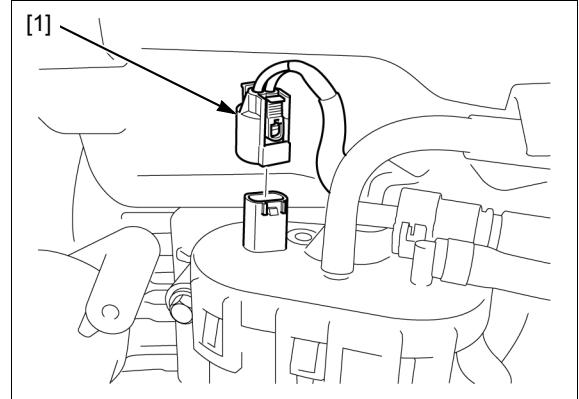

### QUICK CONNECT FITTING REMOVAL

#### FUEL PUMP (HIGH PRESSURE SIDE) SIDE

NOTE:

- Do not bend or twist the fuel hose.
1. Relieve the fuel pressure ([page 6-9](#)).
  2. Check the fuel quick connect fitting [1] for dirt, and clean if necessary.  
Place a shop towel over the quick connect fitting.
  3. Unlock the slide retainer [2] of the quick connect fitting by completely pulling it up.
  4. Release the quick connect fitting from the fuel joint while holding the connector housing.
    - Prevent the remaining fuel in the fuel hose from flowing out, using a shop towel.
    - Be careful not to damage the slide retainer and hose.
    - Do not use tools.
  5. To prevent damage and keep foreign matter out, cover the disconnected connector and pipe end with the plastic bags [1].

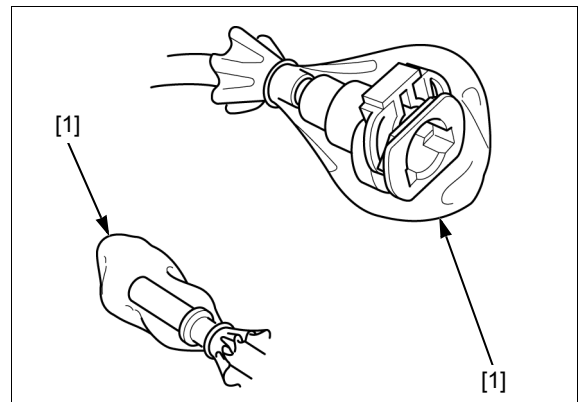
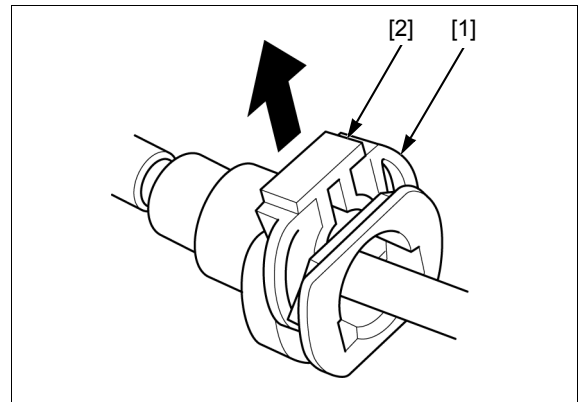

**FUEL INJECTOR SIDE**

**NOTE:**

- Always replace the retainer of the quick connect fitting when the fuel hose is disconnected.
- Do not bend or twist the fuel hose.

1. Relieve the fuel pressure (page 6-6).
2. Remove the air cleaner case (page 6-12).
3. Check the fuel quick connect fitting for dirt, and clean if necessary.

Place a shop towel over the quick connect fitting.

4. Hold the connector [1] with one hand and squeeze the retainer tabs [2] with the other hand to release them from the locking pawls [3].

Pull the connector off, then remove the retainer from the fuel joint.

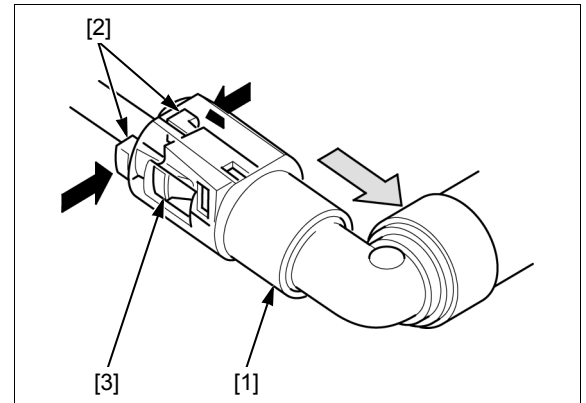

**NOTE:**

- Prevent the remaining fuel in the fuel hose from flowing out with a shop towel.
- Be careful not to damage the hose and other parts.
- Do not use tools.
- If the connector does not move, keep the retainer tabs pressed down, and alternately pull and push the connector until it comes off easily.

5. To prevent damage and keep foreign mater out, cover the disconnected connector and fuel joint with the plastic bags [1].

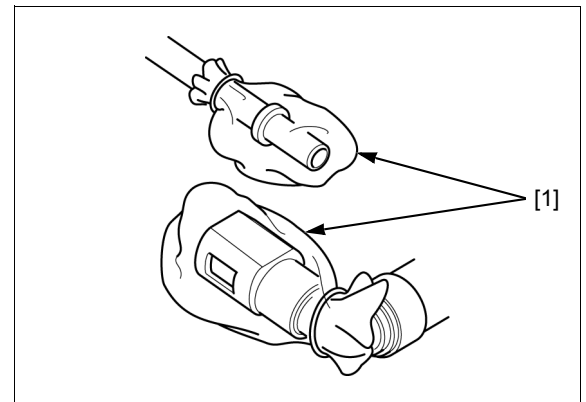

**QUICK CONNECT FITTING INSTALLATION**

**FUEL PUMP (HIGH PRESSURE SIDE) SIDE**

**NOTE:**

- Do not bend or twist the fuel hose.
- Do not reuse a kinked or damaged fuel hose.
- Do not use gloves or a shop towel while installing the quick connect fitting.

1. Be sure that the slide retainer [1] is completely pulled up before connecting the quick connect fitting.

Connect the quick connect fitting to the fuel pipe [2] until you hear the "CLICK" while holding the connector housing [3].

If it is hard to connect, put a small amount of engine oil on the pipe end.

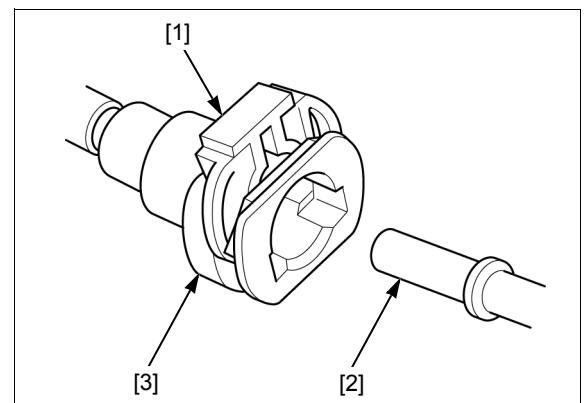

## FUEL SYSTEM

2. Lock the slide retainer by pushing it until you hear the "CLICK".  
Make sure the connection is secure and that the slide retainer [1] is firmly locked into place; check visually and by pulling the connector [2].
3. Normalize the fuel pressure and check that there is no leakage in fuel supply system.

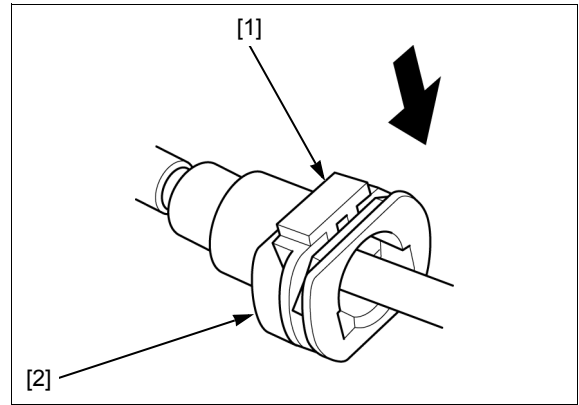

### FUEL INJECTOR SIDE

#### NOTE:

- Always replace the retainer of the quick connect fitting when the fuel hose is disconnected.
- Replace the retainer with the same manufacturer's item that was removed.
- Do not bend or twist the fuel hose.

1. Insert a new retainer [1] into the connector [2].

#### NOTE:

- Align the new retainer locking pawls with the connector grooves.

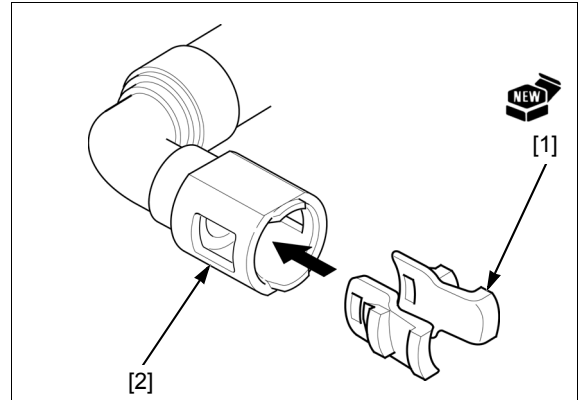

2. Install the connector [1] to the fuel pipe [2].

Then press the quick connect fitting onto the pipe until both locking pawls [3] lock with a click.

If it is hard to connect, put a small amount of engine oil on the pipe end.

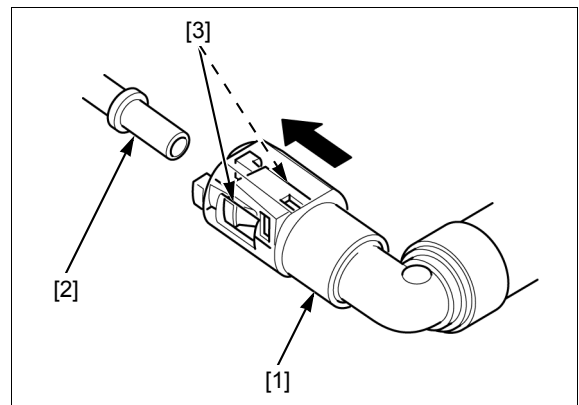

3. Make sure the connection is secure and that the locking pawls [1] are firmly locked into place; check visually and by pulling the connector [2].
4. Install the air cleaner case ([page 6-12](#)).
5. Normalize the fuel pressure and check that there is no leakage in fuel supply system.

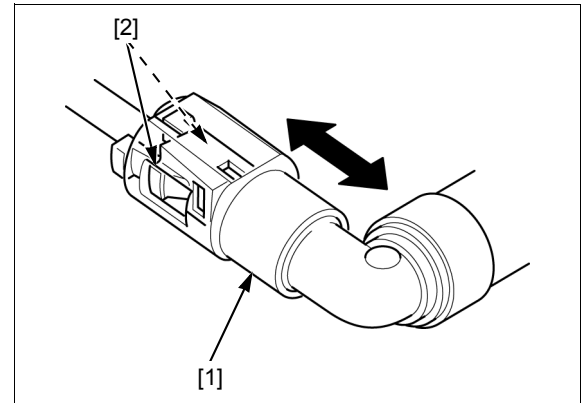

### FUEL PRESSURE NORMALIZATION

1. Connect the fuel pump (high pressure side) 2P connector ([page 6-14](#)).

Connect the battery negative (-) cable.

2. Turn the combination switch ON.

The fuel pump (high pressure side) will run for about 2 seconds and fuel pressure will rise.

#### NOTE:

- Do not start the engine.
3. Turn the combination switch OFF.
  4. Repeat steps 2 and 3 times, and check that there is no leakage in the fuel supply system.

## FUEL SYSTEM

### FUEL PRESSURE TEST

Remove the air cleaner case ([page 6-12](#)).

Disconnect the quick connect fitting from the fuel injector ([page 6-6](#)).

Attach the special tools between the fuel hose B [1] and fuel injector.

#### TOOLS:

- |                                   |               |
|-----------------------------------|---------------|
| [2] Fuel pressure adapter 90° "C" | 07APJ-ZEAA100 |
| [3] Fuel pressure gauge           | 07APJ-Z37A101 |
| [4] Fuel pressure adapter "C"     | 07AAJ-S6MA300 |

Install the air cleaner case ([page 6-12](#)).

Temporarily connect the battery negative (-) cable and fuel pump (high pressure side) 2P (Black) connector.

Start the engine and let it idle.

Read the fuel pressure.

#### STANDARD:

**257 kPa – 284 kPa (2.6 – 2.9 kgf/cm<sup>2</sup>, 37 – 41 psi)**

If the fuel pressure is higher than specified, replace the fuel pump assembly.

If the fuel pressure is lower than specified, inspect the following:

- Fuel line leaking
- Pinched or clogged fuel tube or fuel tank breather tube
- Fuel flow ([page 6-11](#))
- Clogged fuel filter
- Fuel pump

After inspection, relieve the fuel pressure ([page 6-6](#)).

Remove the special tools.

Connect the quick connect fitting ([page 6-7](#)).

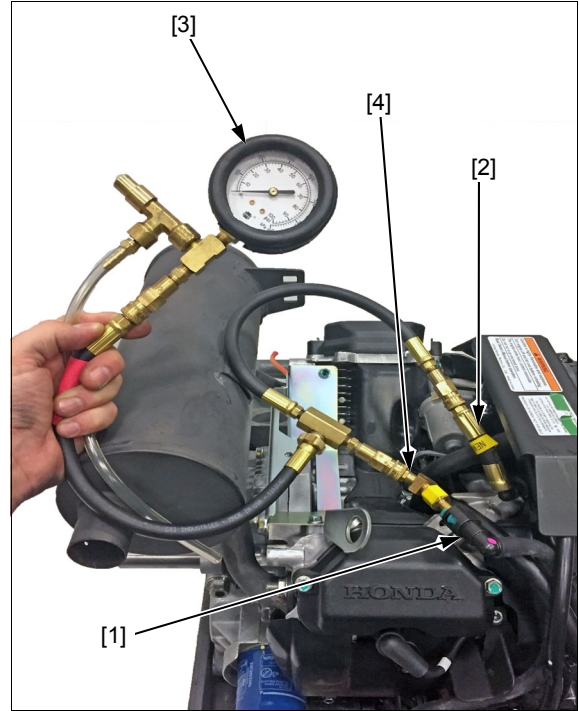

## FUEL FLOW INSPECTION

**NOTE:**

- Place the engine on a level surface.

Disconnect the quick connect fitting from the fuel injector ([page 6-6](#)).

Place the end of the fuel hose B [1] into an approved fuel container [2].

Temporarily connect the battery negative (-) cable and fuel pump (high pressure side) 2P (Black) connector.

Turn the combination switch ON.

Measure the amount of fuel flow.

**NOTE:**

- The fuel pump operates for 5 seconds.
- Return the fuel collected back into the fuel tank or discard it using an appropriate disposal method.

**Amount of fuel flow:**

**18 cm<sup>3</sup> (0.61 US oz, 0.63 Imp oz) minimum/  
5 seconds at 12 V**

If the fuel flow is less than specified, inspect the following:

- Fuel filter
- Pinched or clogged fuel hose or fuel tank breather tube
- Fuel pump

Connect the quick connect fitting ([page 6-7](#)).

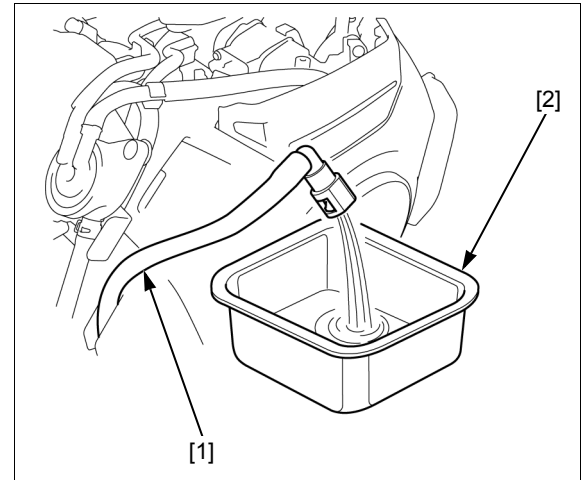

# AIR CLEANER

## REMOVAL/INSTALLATION

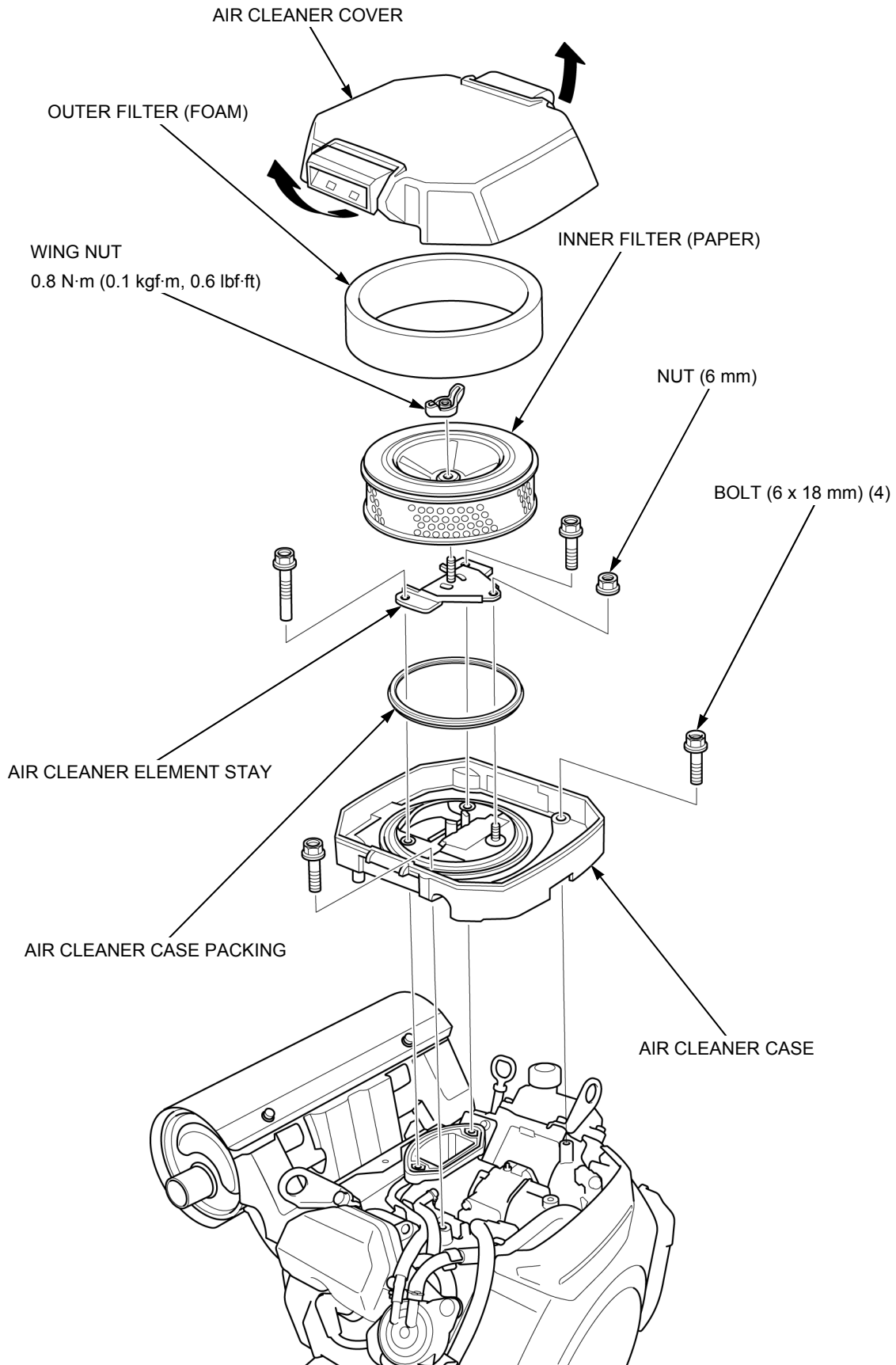

# FUEL PUMP (LOW PRESSURE SIDE)

## REMOVAL/INSTALLATION

### ⚠ WARNING

Gasoline is highly flammable and explosive. You can be burned or seriously injured when handling fuel.

- Keep heat, sparks and flame away.
- Handle fuel only outdoors.
- Wipe up spills immediately.

Remove the air cleaner ([page 6-12](#)).

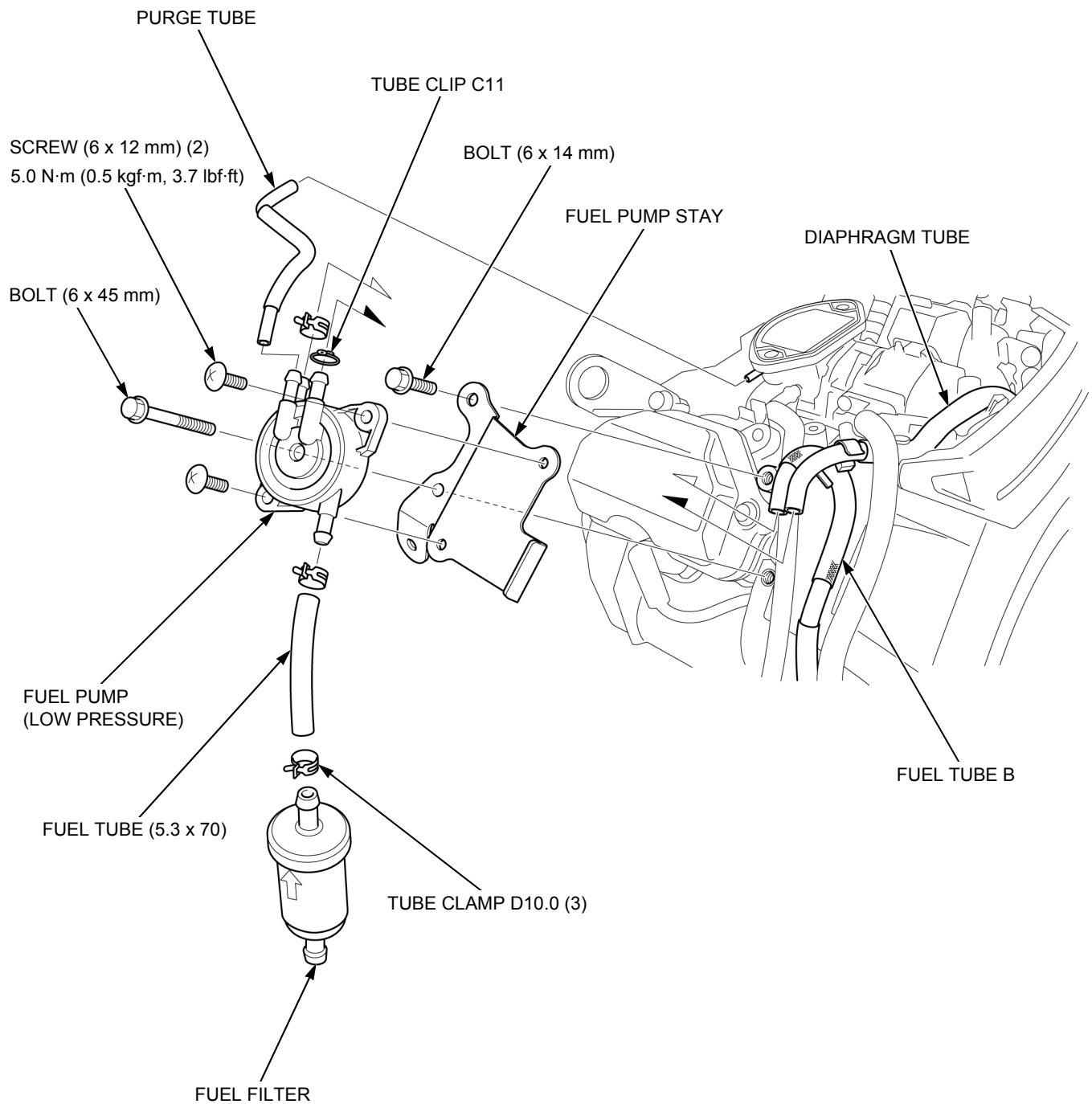



## FUEL SYSTEM

# FUEL PUMP (HIGH PRESSURE SIDE)

### REMOVAL/INSTALLATION

#### **⚠ WARNING**

Gasoline is highly flammable and explosive. You can be burned or seriously injured when handling fuel.

- Keep heat, sparks and flame away.
- Handle fuel only outdoors.
- Wipe up spills immediately.

Remove the fuel pump (low pressure side) ([page 6-13](#)).

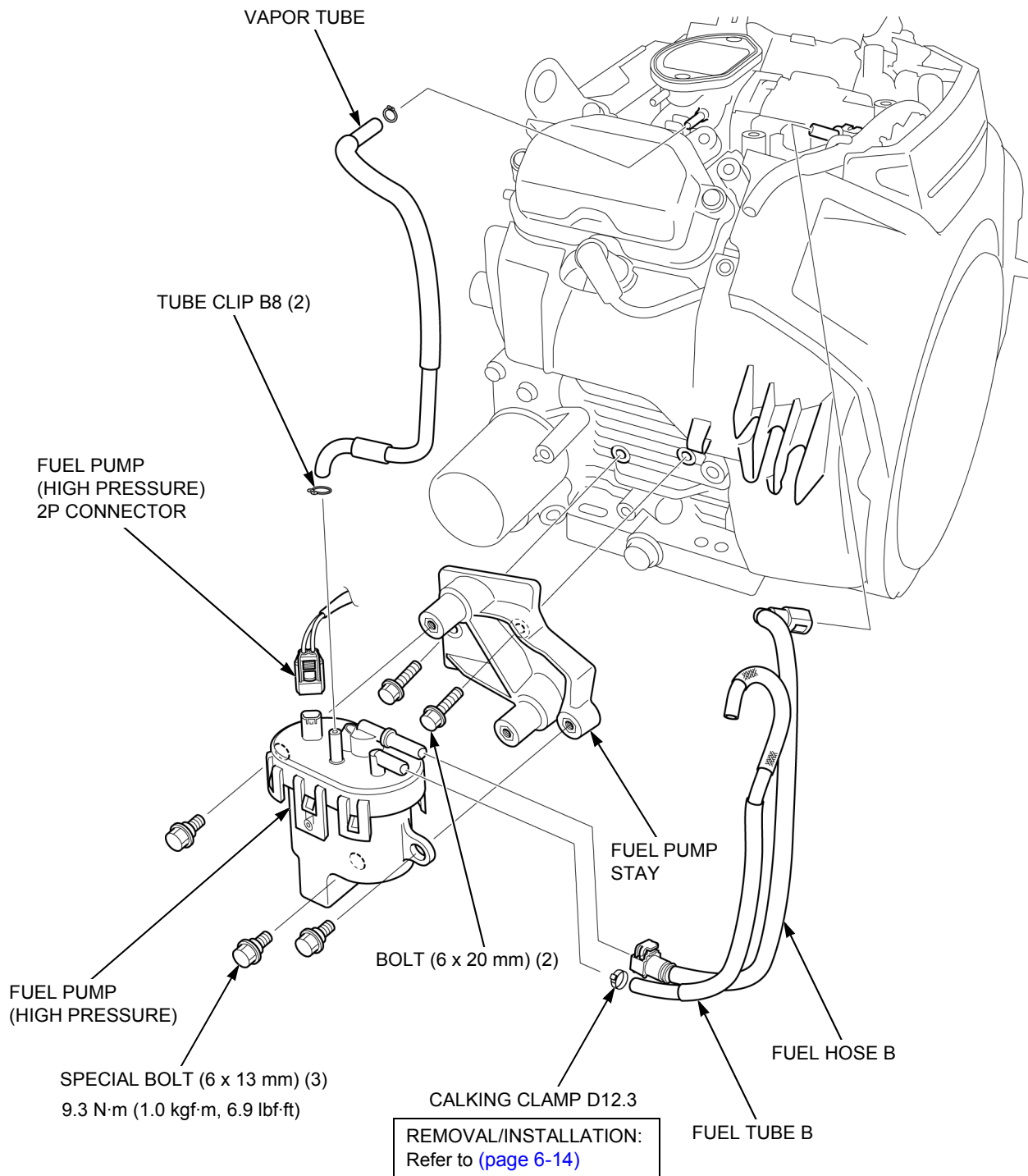

## CAULKING CLAMP

### REMOVAL/INSTALLATION

Cut off and remove the caulking clamp [1] then disconnect the fuel tube.

Install a new caulking clamp onto the fuel tube [2] then connect the fuel tube.

Pinch the ear portion of the caulking clamp with a pincher [3] until the pinched area clearance is 2.2 – 3.2 mm (0.09 – 0.13 in) as shown to secure fuel hose.

#### TOOL:

**Pincher [3]                      Oetiker 1098 or equivalent**

#### EAR PORTION WIDTH:

**Standard: 7.3 – 8.5 mm (0.29 – 0.33 in)**

**Pinched: 2.2 – 3.2 mm (0.09 – 0.13 in)**

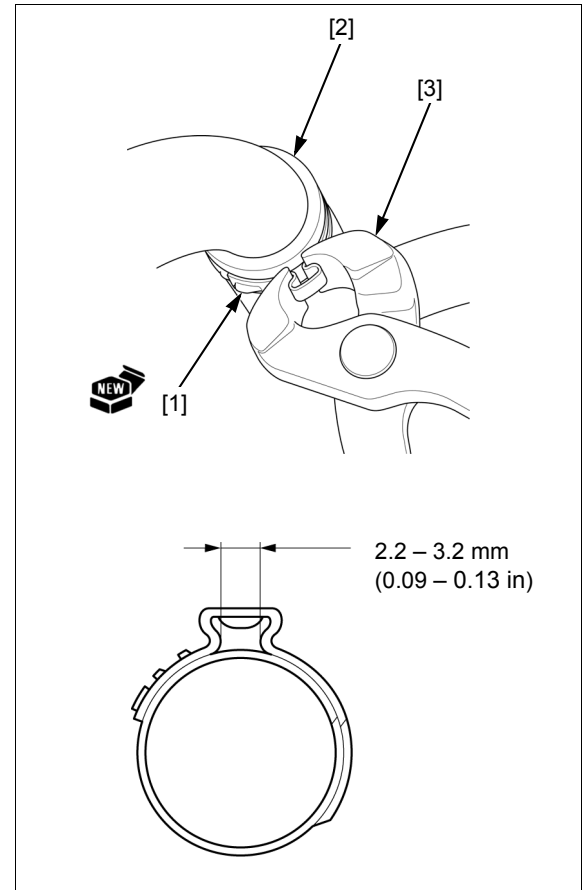

# THROTTLE BODY/INLET MANIFOLD/ FUEL INJECTOR

## REMOVAL/INSTALLATION

### ⚠ WARNING

Gasoline is highly flammable and explosive. You can be burned or seriously injured when handling fuel.

- Keep heat, sparks and flame away.
- Handle fuel only outdoors.
- Wipe up spills immediately.

Remove the following:

- Air cleaner (page 6-12)
- Fan cover (page 5-2)
- Fuel pump (low pressure side) (page 6-13)

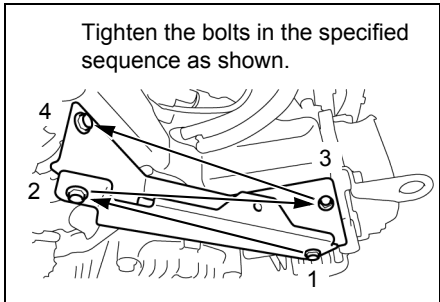
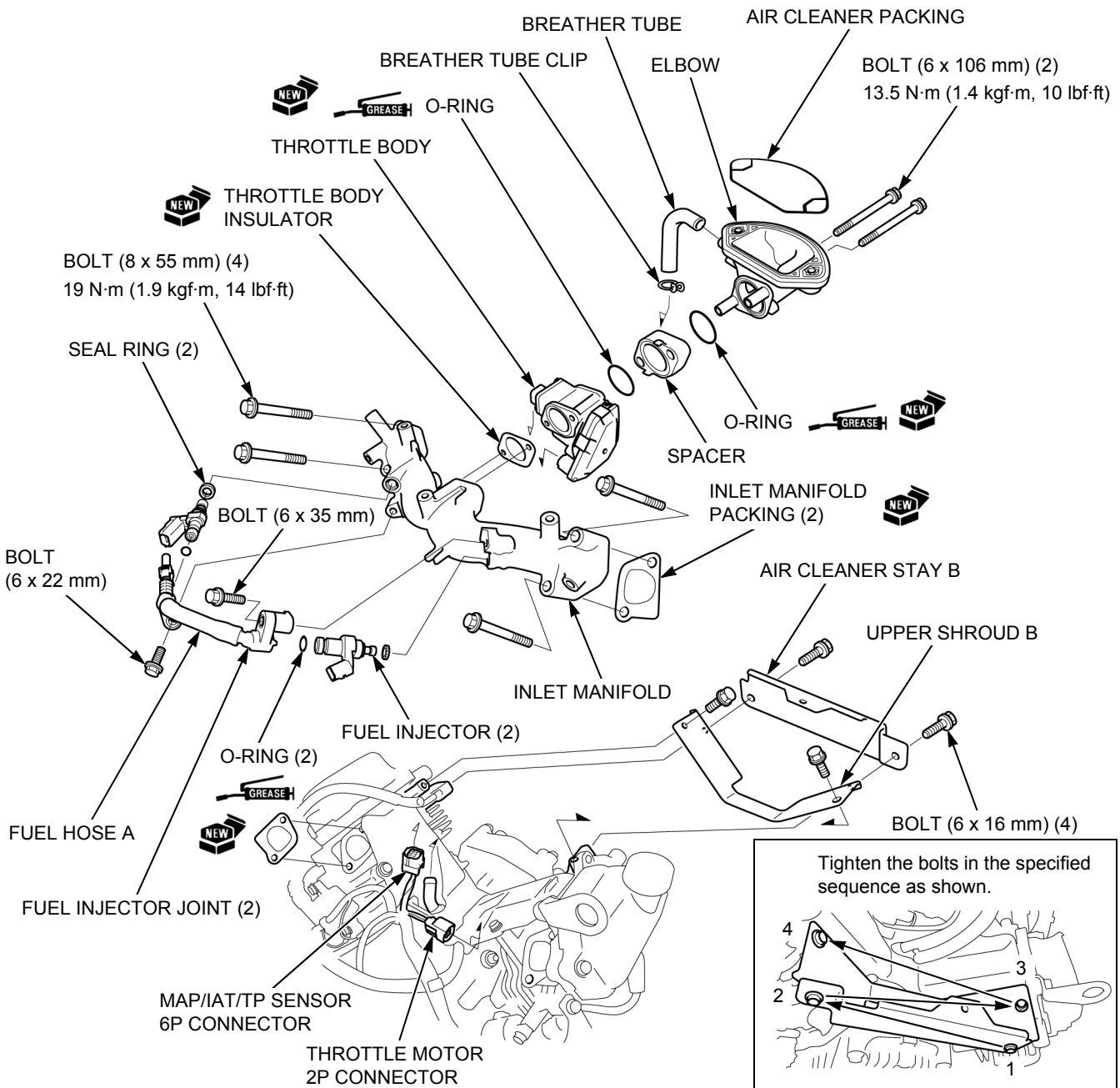

**FUEL INJECTOR INSPECTION**

Remove the air cleaner ([page 6-12](#)).

Disconnect the fuel injector 2P connector.

Measure the resistance between the fuel injector connector terminals.

**STANDARD:**      **11 – 13  $\Omega$  (24°C/75°F)**

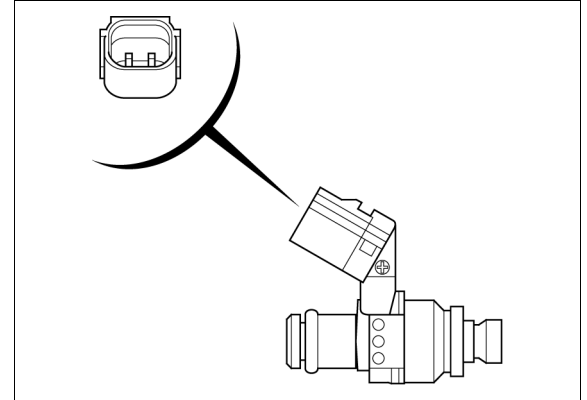

---

**MEMO**

---

# 7. CHARGING SYSTEM

---

SYSTEM DIAGRAM .....	7-2	CHARGE COIL .....	7-7
TROUBLESHOOTING .....	7-3	REGULATOR/RECTIFIER .....	7-8
COOLING FAN/FLYWHEEL .....	7-4		

# CHARGING SYSTEM SYSTEM DIAGRAM

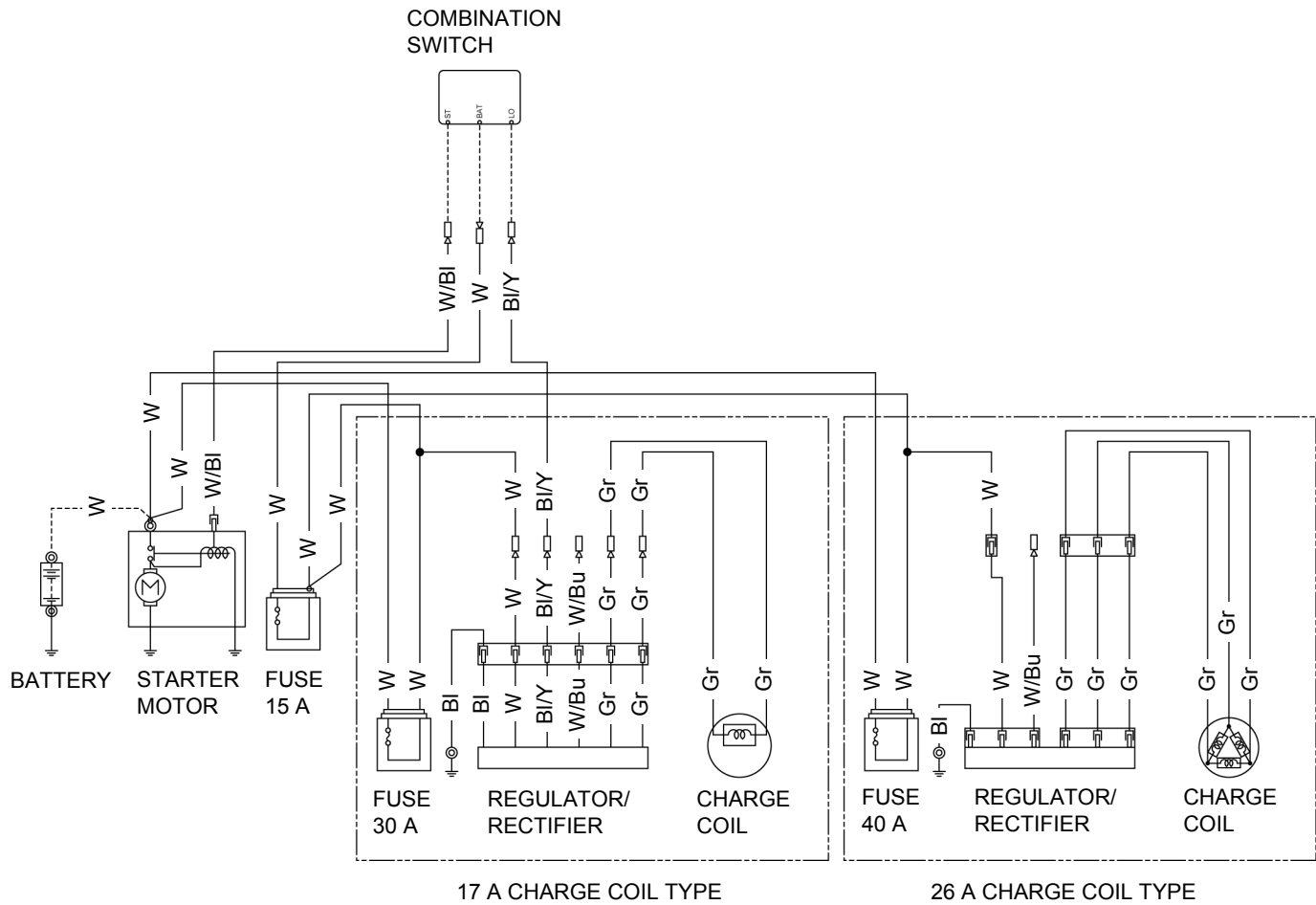

# TROUBLESHOOTING

## BATTERY DAMAGED OR WEAK (assuming battery is capable of accepting charge)

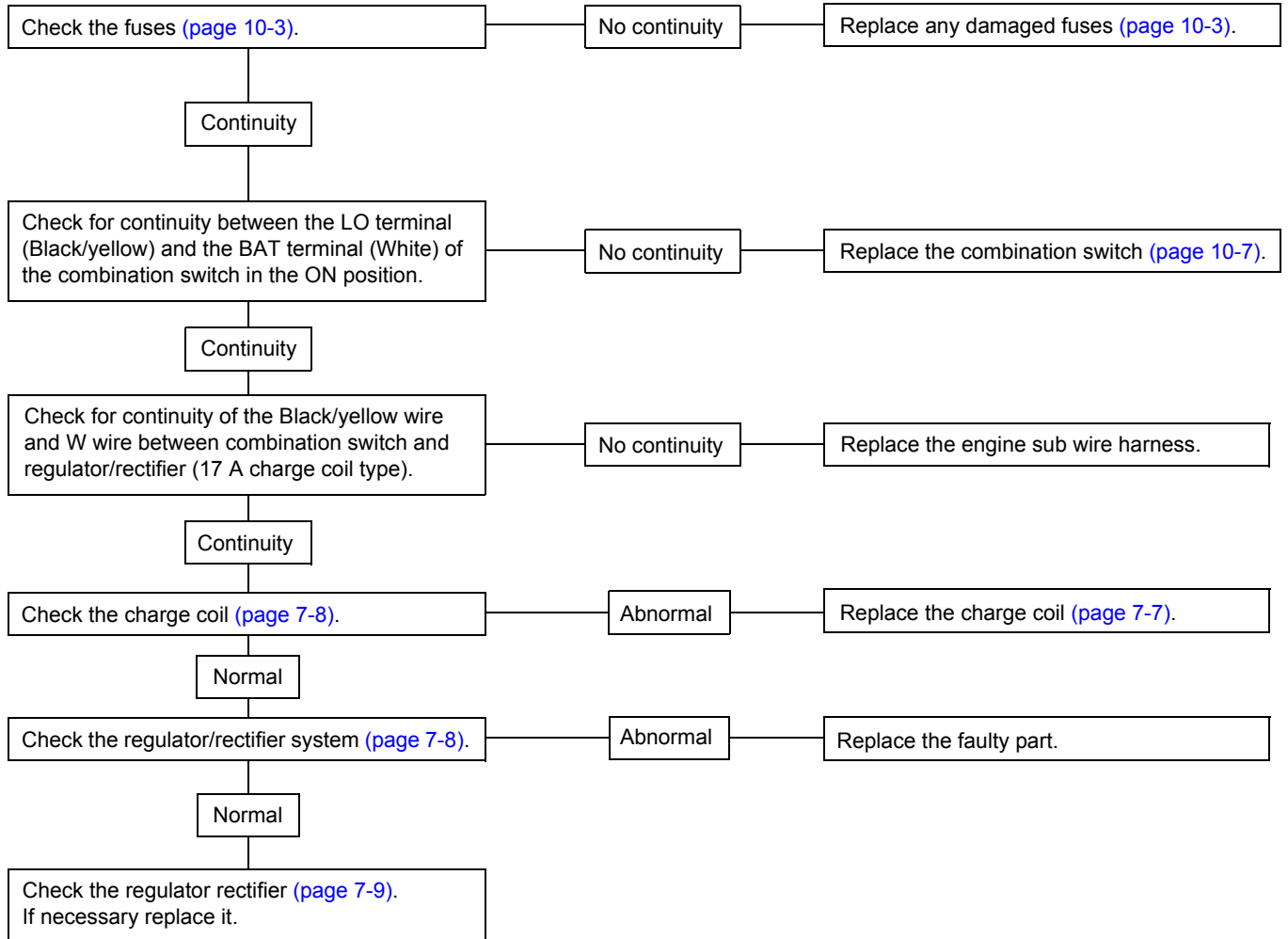



## COOLING FAN/FLYWHEEL

### REMOVAL

Remove the CKP sensor (page 10-3).

Attach the special tools to the flywheel.

**TOOL:**

**Flywheel puller**

**070PC-ZDW0100**

Install the stud bolts [1], collars [2], and socket [3].

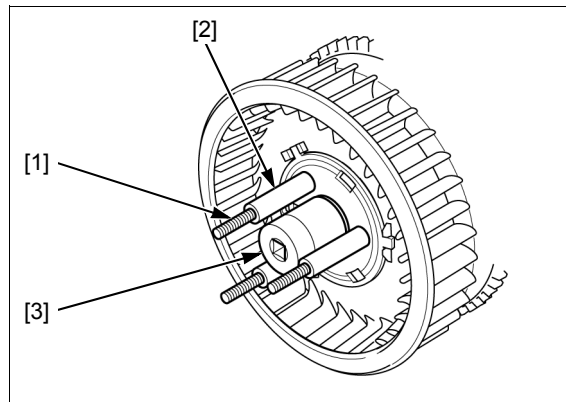

Install the holder plate [1], nuts [2], and extension bar [3].

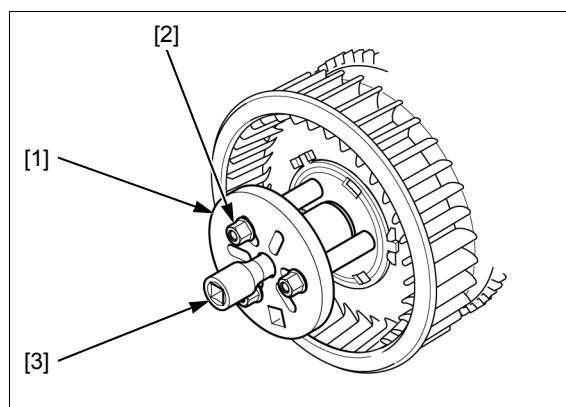

Hold the flywheel with the special tool and loosen the special nut [1].

**NOTE:**

- Loosen the special nut until the nut touches the plate [2].

Turn special nut counterclockwise again to remove the flywheel [3].

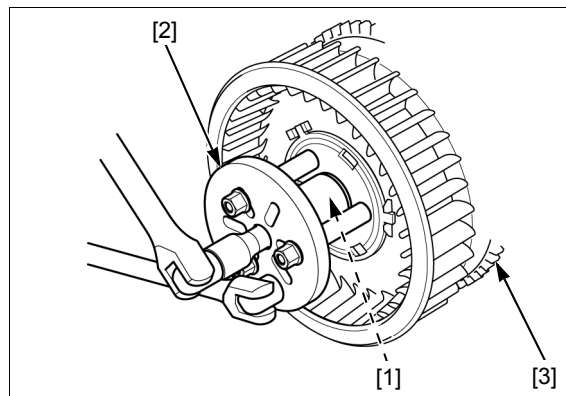

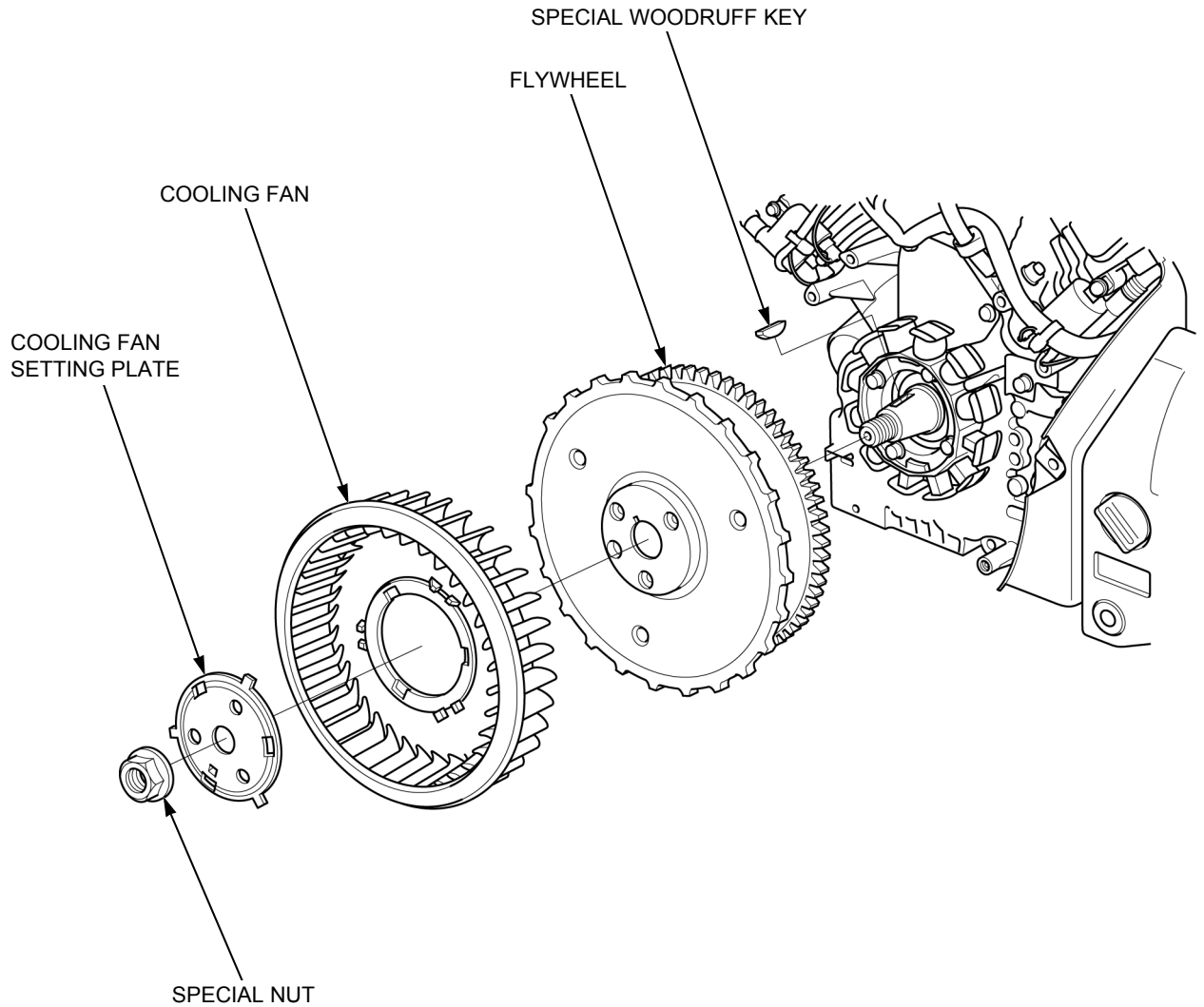

**INSTALLATION**

Clean the tapered part of the crankshaft [1] and flywheel [2] of dirt, oil, grease and other foreign material before installation. Be sure there are no metal parts or other foreign material on the magnet part of the flywheel.

Set the special woodruff key in the key groove of the crankshaft securely.

Install the flywheel on the crankshaft.

**NOTICE**

*The flywheel may push the key out of its slot; check after installation.*

Attach the cooling fan [3] by aligning the holes [4] with projections [5] as shown.

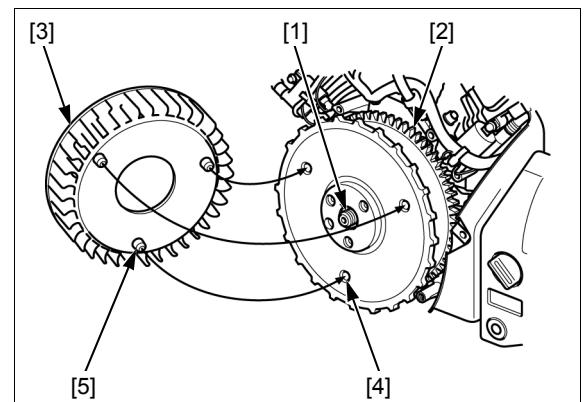

## CHARGING SYSTEM

Attach the cooling fan setting plate [1] to the cooling fan [2] by aligning the tabs of the cooling fan setting plate with the projections of the cooling fan.

Rotate the cooling fan setting plate clockwise to touch the claw of the cooling fan setting plate with projections of the cooling fan.

Apply engine oil to the threads and seating surface of the special nut [3] and install it.

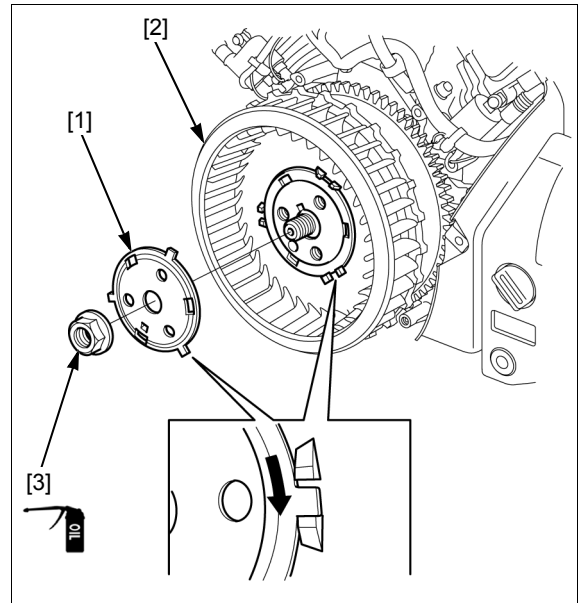

Attach the special tools to the flywheel.

**TOOL:**  
**Flywheel puller 070PC-ZDW0100**

Install the stud bolts [1], collars [2], and socket [3].

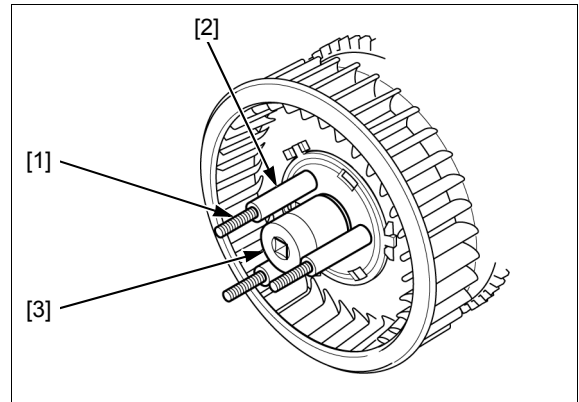

Install the holder plate [1], nuts [2], and extension bar [3].

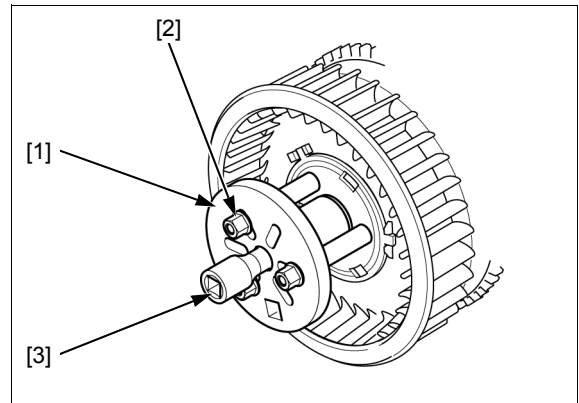

Hold the flywheel [1] with special tools, and tighten the special nut [2] to the specified torque.

**TORQUE: 245 N·m (25 kgf·m, 181 lbf·ft)**

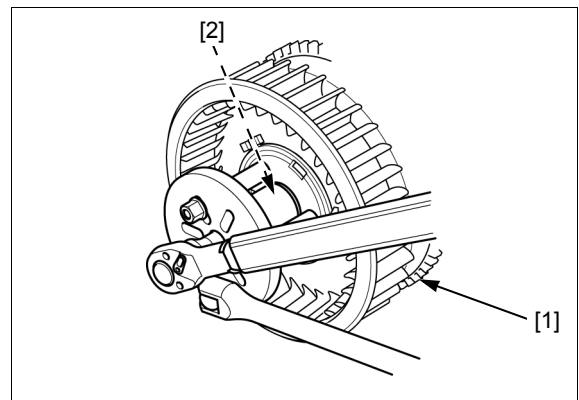

# CHARGE COIL

## REMOVAL/INSTALLATION

Remove the flywheel (page 7-4).

Remove the ECU (page 10-2).

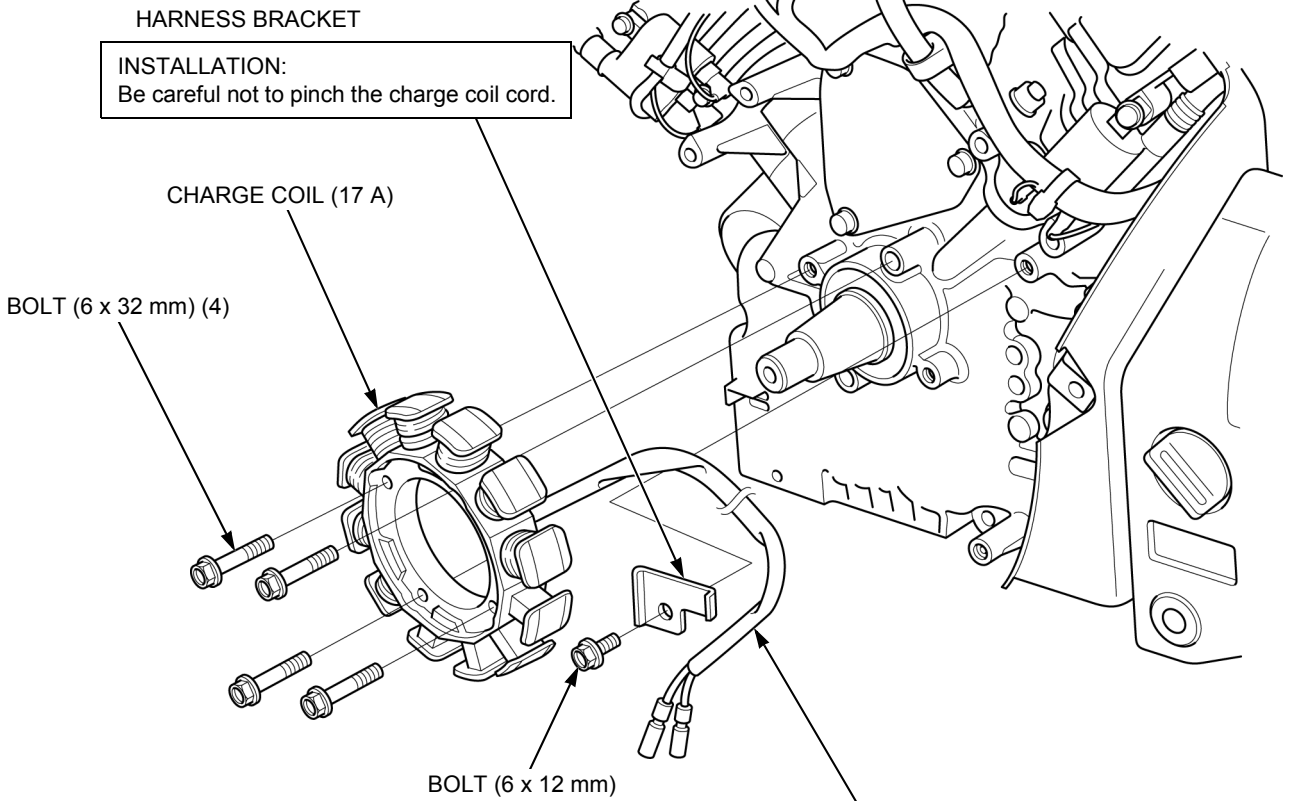
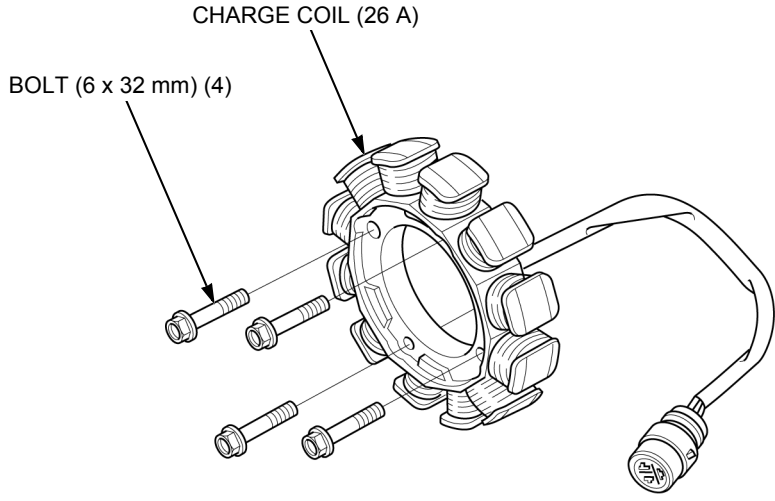

**REMOVAL:**  
Remove the wire band and pull the wire harness out of the grommet.

**INSTALLATION:**  
Route the cord and wire harness through the grommet and install the wire band.

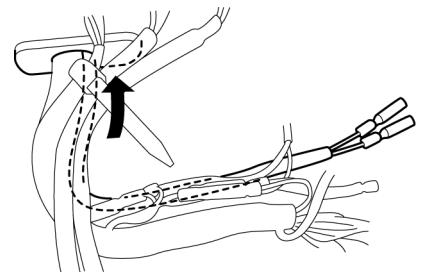

## CHARGING SYSTEM

### INSPECTION

Disconnect the charge coil connector/s.

Measure the resistance between the terminals of the charge coil.

**Resistance:**

**17 A: 0.18 – 0.28  $\Omega$**

**26 A: 0.17 – 0.25  $\Omega$**

Check for continuity between each terminal and engine ground.

There should be no continuity.

If the measured resistance is not within the range specification or if any wire has continuity to engine ground, replace the charge coil ([page 7-7](#)).

26 A type shown:

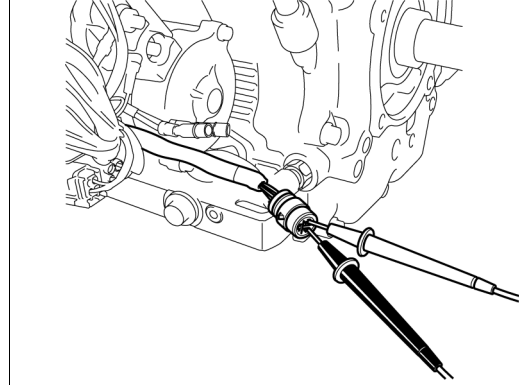

## REGULATOR/RECTIFIER

### SYSTEM INSPECTION

Disconnect the regulator/rectifier connector(s) and check the following at the regulator/rectifier connector terminals (wire harness side) as follows:

Item	Terminal	Specification
Battery charging line	White (+) and ground	Battery voltage should register
Charge coil line	Gray and Gray	17 A: 0.18 – 0.28 $\Omega$
		26 A: 0.17 – 0.25 $\Omega$
Ground line	Black and ground	Continuity should exist

**INSPECTION**

Disconnect the regulator/rectifier connector/s.

Measure the resistance between the terminals and be sure that the measurements are within the specifications in the table below.

Use a commercially available multimeter (FLU88) to perform the following tests in the table below. Select a range that is equal to or higher than the range specified in the table.

17 A: Unit: Ω

		(+ ) probe		
		ACG1	ACG2	BAT
(-) probe	ACG1	—	∞	290 – 22k
	ACG2	∞	—	290 – 22k
	BAT	∞	∞	—
	SENSE	80k – ∞	80k – ∞	120k – ∞
	CHG.M	150k – ∞	150k – ∞	300k – ∞
	GND	∞	∞	∞

		(+ ) probe		
		SENSE	CHG.M	GND
(-) probe	ACG1	∞	∞	∞
	ACG2	∞	∞	∞
	BAT	∞	∞	∞
	SENSE	—	2k – 150k	8k – 150k
	CHG.M	300 – 30k	—	20k – 300k
	GND	∞	∞	—

26 A: Unit: Ω

		(+ ) probe		
		ACG1	ACG2	ACG3
(-) probe	ACG1	—	30k – 420k	30k – 420k
	ACG2	30k – 420k	—	30k – 420k
	ACG3	30k – 420k	30k – 420k	—
	BAT	30k – 420k	30k – 420k	30k – 420k
	LAMP	∞	∞	∞
	GND	30k – 950k	30k – 950k	30k – 950k

		(+ ) probe		
		BAT	LAMP	GND
(-) probe	ACG1	∞	∞	∞
	ACG2	∞	∞	∞
	ACG3	∞	∞	∞
	BAT	—	30k – 340k	15k – 190k
	LAMP	∞	—	∞
	GND	400 – 25k	30k – 420k	—

17 A TYPE:

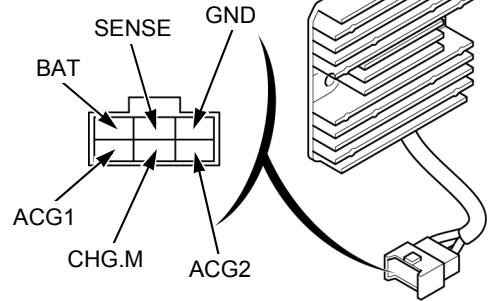

26 A TYPE:

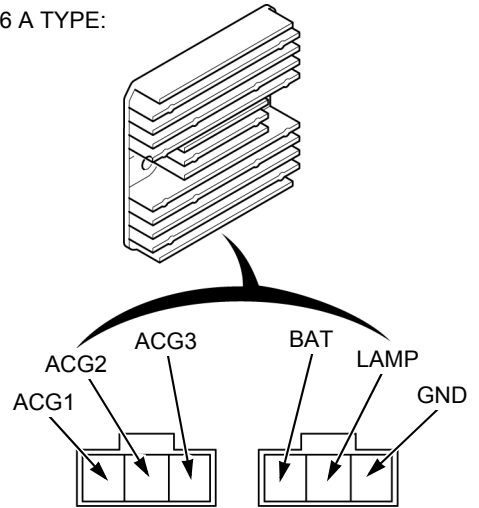

---

**MEMO**

---

# 8. IGNITION SYSTEM

---

SYSTEM DIAGRAM .....8-2      IGNITION COIL .....8-3  
TROUBLESHOOTING.....8-2      SPARK TEST .....8-4



# IGNITION SYSTEM

## SYSTEM DIAGRAM

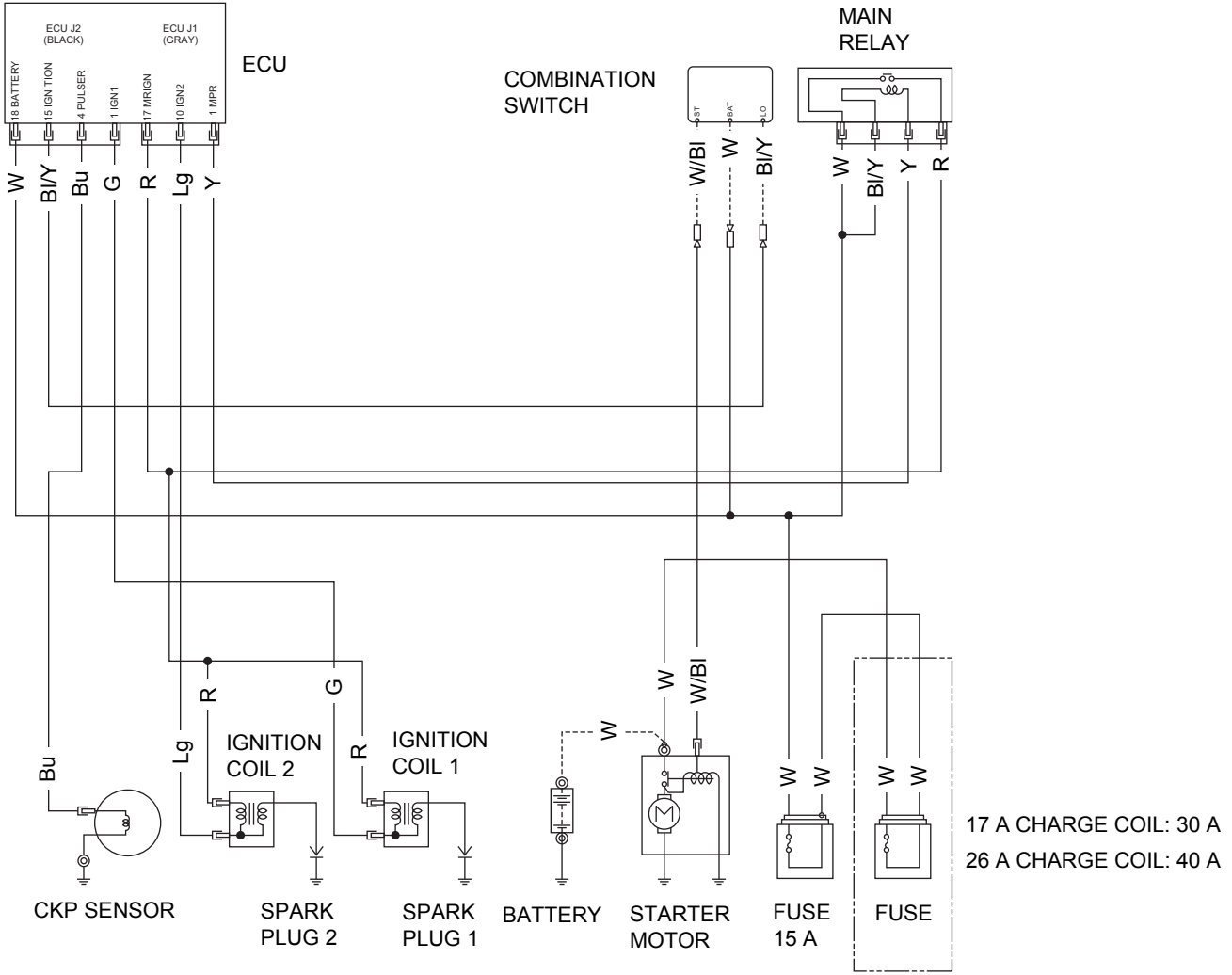

## TROUBLESHOOTING

### NO SPARK AT SPARK PLUG

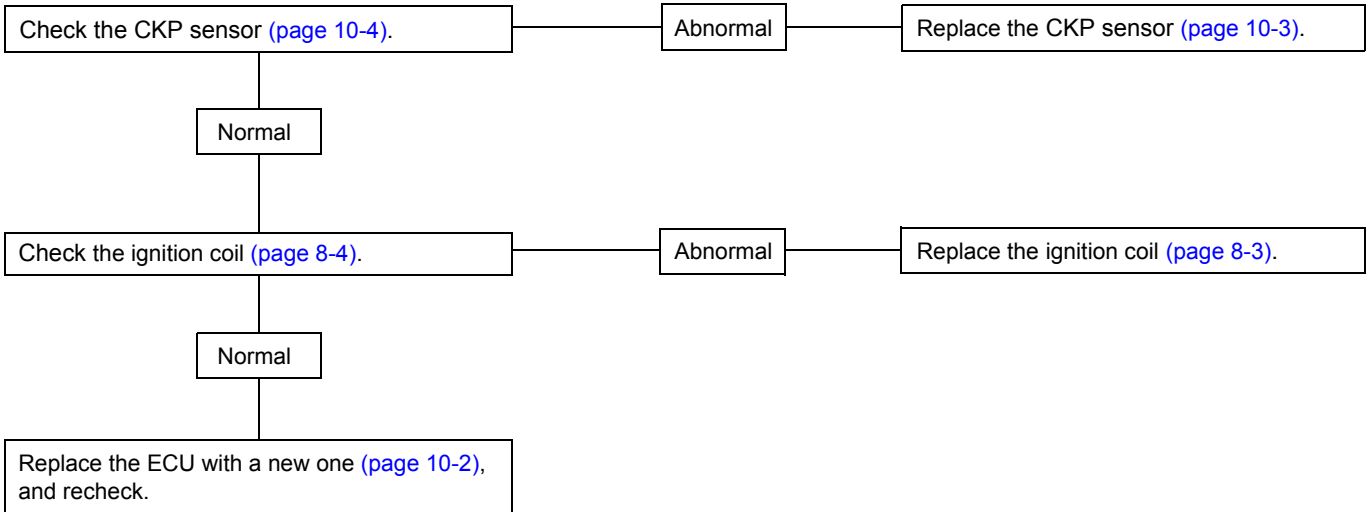

# IGNITION COIL

## REMOVAL/INSTALLATION

Remove the following:

- Fan cover (page 5-2).
- L./R. lower shrouds (page 5-3).

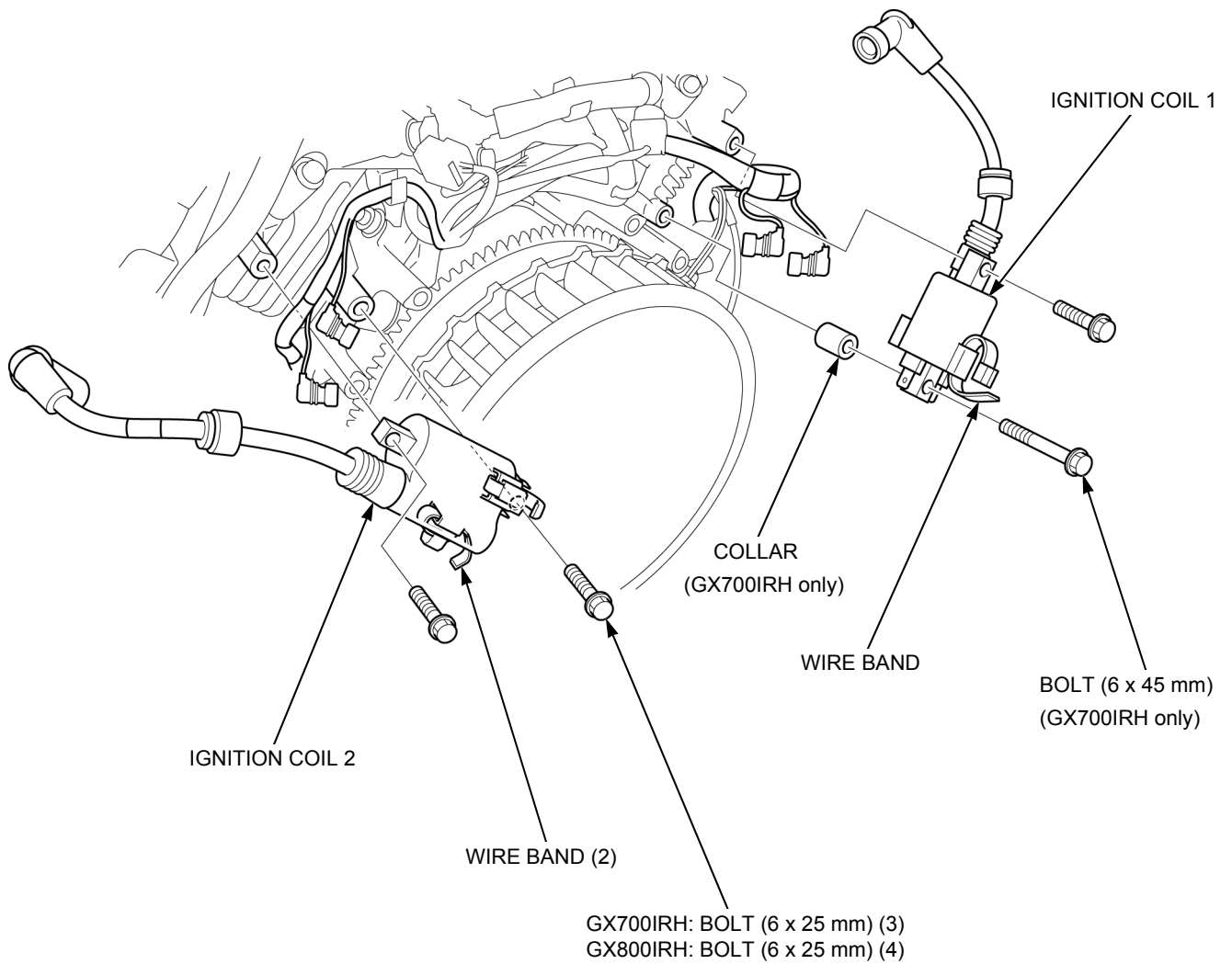

## IGNITION SYSTEM

### INSPECTION

Remove the ignition coil (page 8-3).

#### Primary side:

Measure the resistance at the ignition coil terminals.

**STANDARD: 1.8 – 2.8  $\Omega$**

Replace the ignition coil if the measurement is out of specification (page 8-3).

#### Secondary side:

Measure the resistance at the ignition coil G terminal and plug cap.

**STANDARD: 7.4 – 11.2 k $\Omega$**

Replace the ignition coil if the measurement is out of specification (page 8-3).

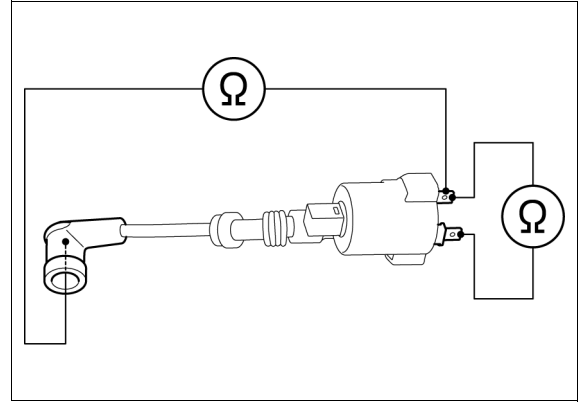

## SPARK TEST

Disconnect the fuel pump (high pressure side) 2P connector (page 6-14).

Inspect the following before spark test.

- Faulty spark plug
- Loose spark plug cap
- Water in the spark plug cap (Leaking the ignition coil secondary voltage)
- Check the ignition coil connection

Disconnect the spark plug caps [1] from the spark plugs [2].

Connect a known-good spark plug [3] to the spark plug cap and ground the spark plug to the head cover bolt [4].

Crank the engine by operating the starter motor several seconds and check whether sparks jump across the electrode.

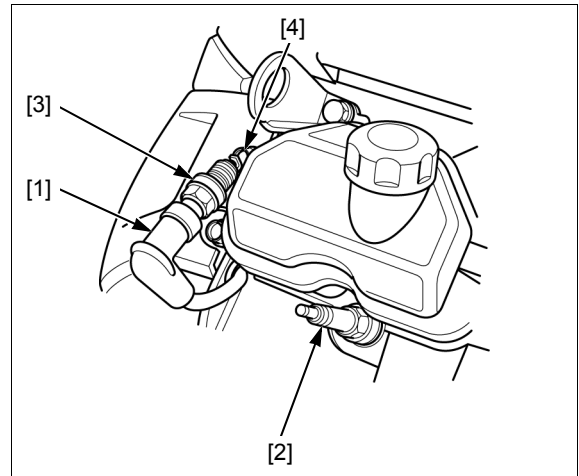

### NOTICE

*Do not operate the starter motor for more than 5 seconds at a time. When operating the starter motor several times in a row, wait 10 – 20 seconds between operation to recover the battery voltage.*

# 9. STARTING SYSTEM

---

SYSTEM DIAGRAM .....9-2  
TROUBLESHOOTING.....9-3

STARTER MOTOR .....9-4

# STARTING SYSTEM SYSTEM DIAGRAM

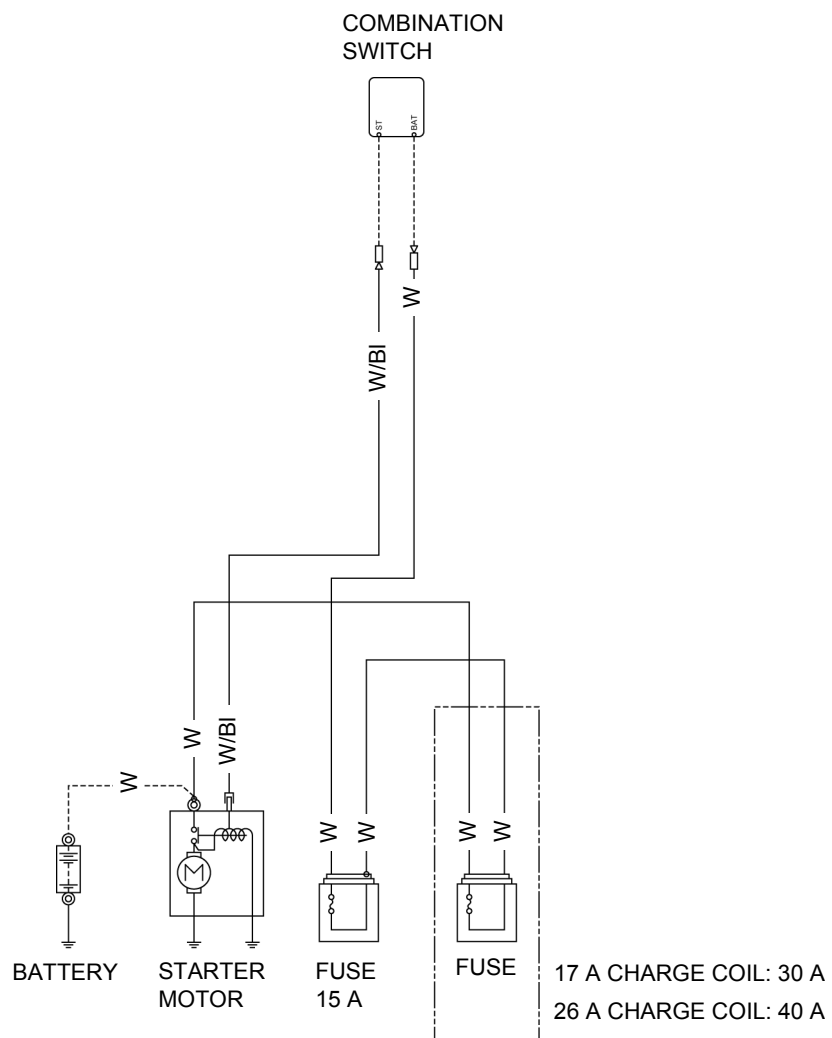

# TROUBLESHOOTING

## STARTER MOTOR DOES NOT OPERATE

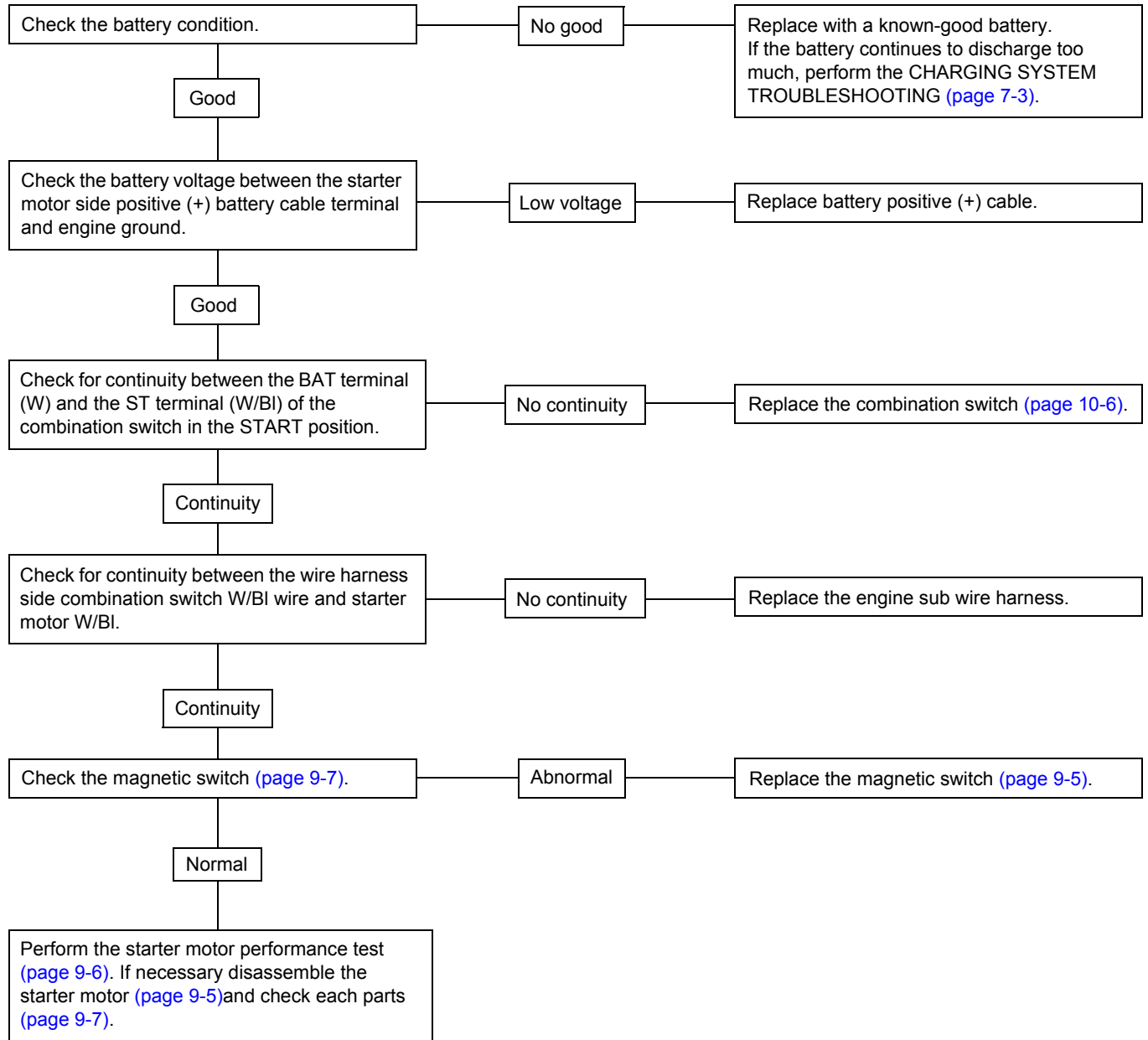

**STARTING SYSTEM**

**STARTER MOTOR**

**REMOVAL/INSTALLATION**

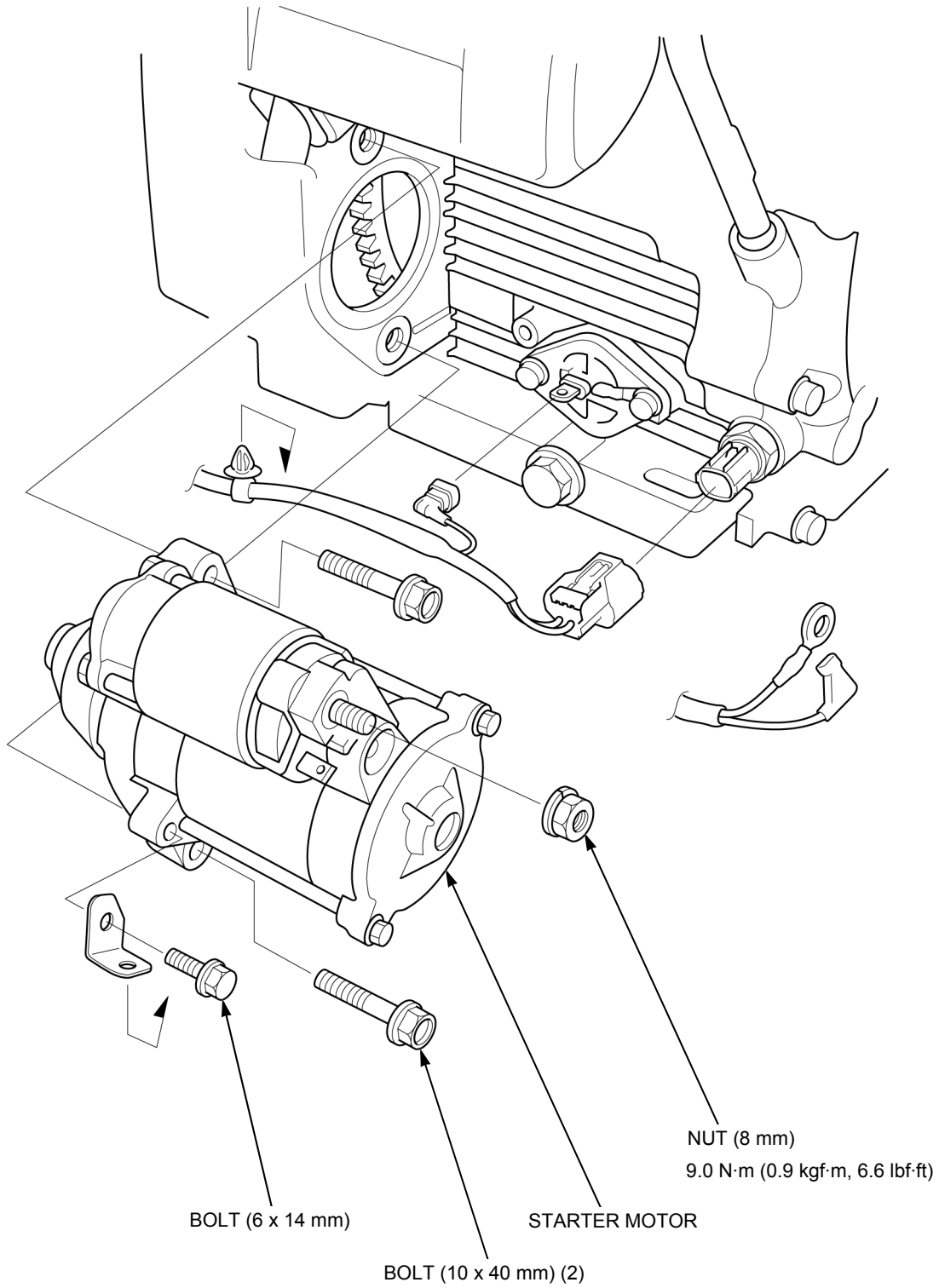

**DISASSEMBLY**

**ARMATURE**

**ASSEMBLY:**  
Visually inspect the commutator surface for dust or other damage. If necessary, wipe it with a clean lint-free cloth. If rusted or damaged, dress with a fine emery paper.

**TERMINAL COVER**

**MAGNETIC SWITCH**

**PINION DRIVE LEVER**

**SNAP RING**

**DISASSEMBLY:**  
Hold the armature [1] upright and drive the clutch stop collar A [2] down as shown. Then remove the snap ring [3].

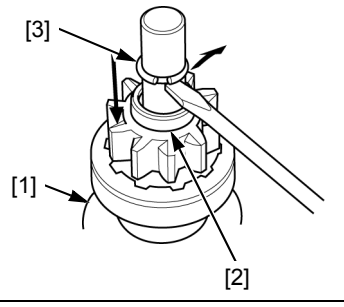

**OVERRUNNING CLUTCH**

**CLUTCH STOP COLLAR A**

**NUT (2)**

**DRIVE HOUSING**

**THROUGH BOLT (2)**

**CLUTCH STOP COLLAR B**

**COMMUTATOR END FRAME**

**NEEDLE BEARING**

**BRUSH HOLDER INSULATOR**

**BRUSH SPRING (4)**

**BRUSH (4)**

**BRUSH HOLDER**

**YOKE**

**ASSEMBLY:**  
Make sure that there is no obstruction on the magnets.

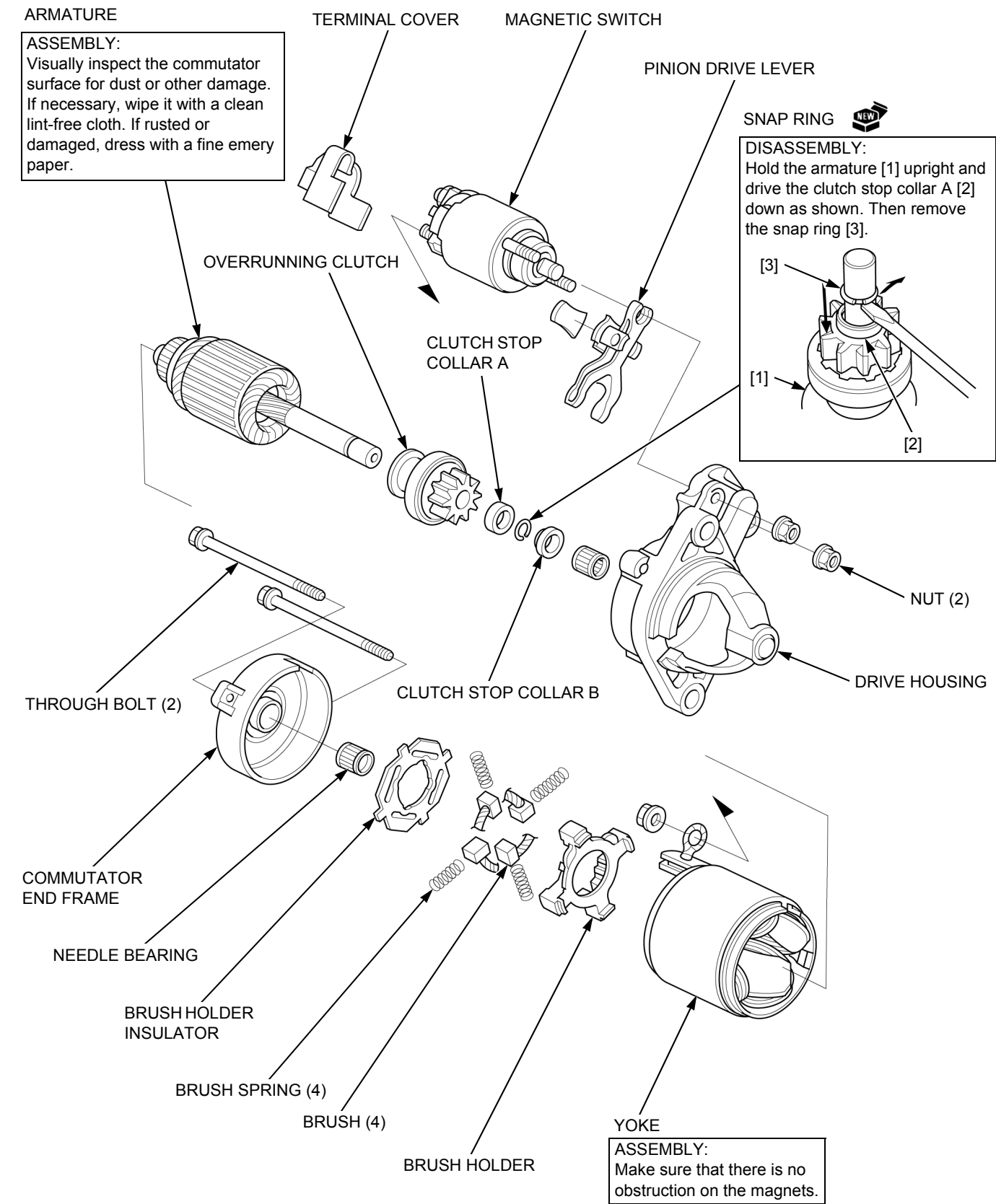



## STARTING SYSTEM

### ASSEMBLY

Attach the pinion drive lever [1] to the magnetic switch [2]. Set the pinion drive lever to the overrunning clutch [3] of the armature.

Install the magnetic switch and armature to the drive housing [4] and tighten the flange nuts to secure the magnetic switch.

Install the yoke [5] to the drive housing.

Install the brush holder [6] to the yoke, and set the brushes [7] and brush springs [8] to the brush holder. Install the brush holder insulator [9].

Install the commutator end frame [10] by aligning the brush terminal grommet [11] with the cutout of the commutator end frame.

Tighten the through bolts to secure the drive housing and commutator end frame.

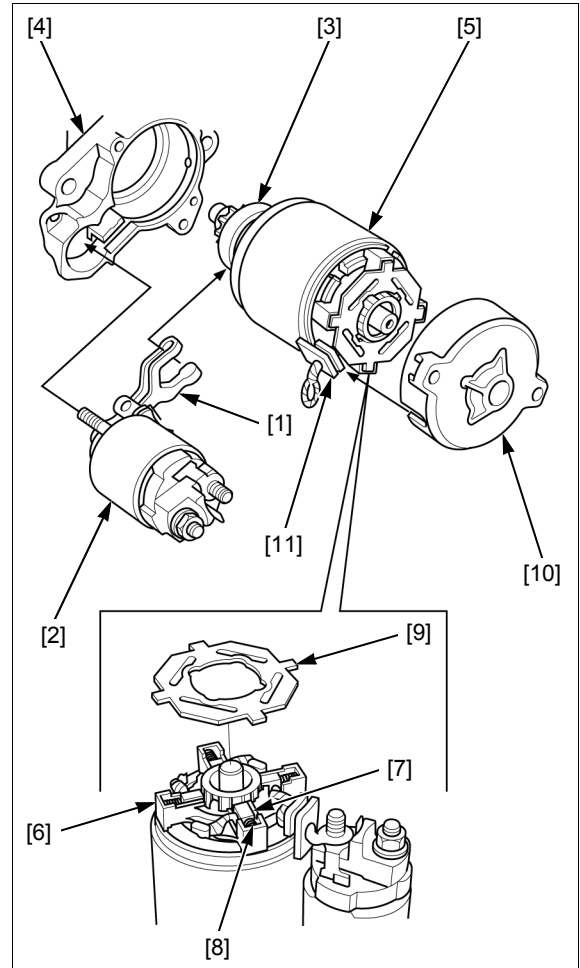

### INSPECTION

#### PERFORMANCE TEST

Measure starter performance while cranking the engine.

#### STARTER MOTOR PERFORMANCE:

##### UNDER LOAD:

**CRANKING VOLTAGE:** 9 V

**CRANKING CURRENT:** 150 A

**ENGINE CRANKING SPEED:** 1,950 rpm min.

##### NO LOAD:

**CRANKING VOLTAGE:** 11.5 V

**CRANKING CURRENT:** 50 A max.

- To get accurate results, the test must be performed in the normal ambient temperature.
- Battery: 55B24 (12 V 36 AH/5 HR)
- Battery cable: 15 sq x 1.5 m (4.9 ft) each for battery positive cable and battery negative cable.

If the measurement is out of specification, disassemble and inspect the starter motor.

## MAGNETIC SWITCH

Check the continuity between the terminals of the magnetic switch.

There should be no continuity between the terminals.

If there is continuity, replace the magnetic switch ([page 9-5](#)).

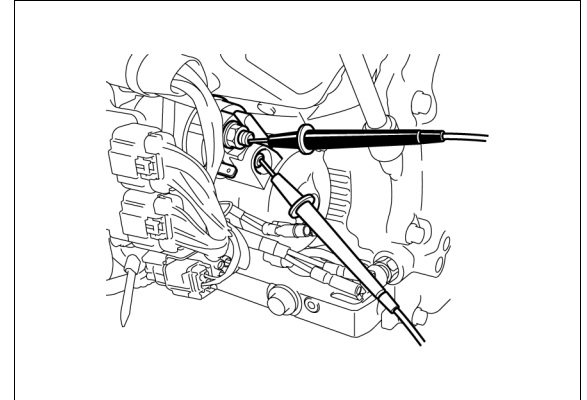

## BRUSH LENGTH

Measure the brush length.

**STANDARD:** 10 mm (0.4 in)

**SERVICE LIMIT:** 6.0 mm (0.2 in)

If brush length is less than the service limit, replace the brush ([page 9-9](#)).

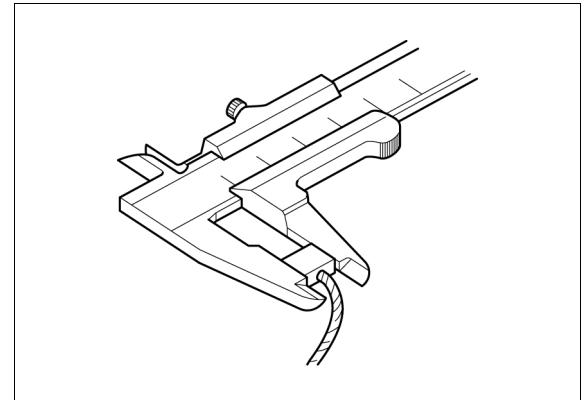

## BRUSH CONTINUITY CHECK

Check for continuity between the positive (+) brushes [1] and negative (-) brushes [2].

There should be continuity between both the positive brushes.

There should be continuity between both the negative brushes.

There should be no continuity between both the positive and negative brushes.

If the correct continuity is not obtained, replace the yoke ([page 9-5](#)).

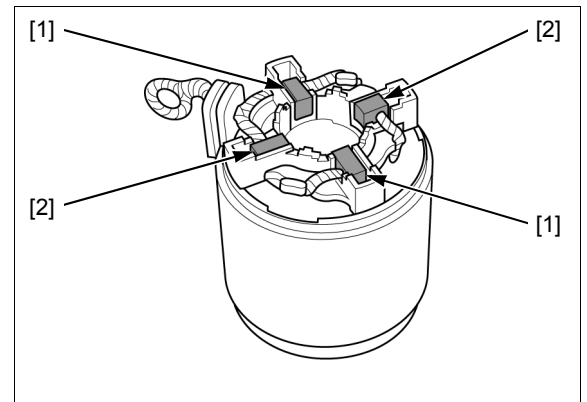

## OVERRUNNING CLUTCH

Hold the armature [1] as shown and check that the overrunning clutch [2] turns clockwise and slides smoothly. If necessary, apply oil or replace the overrunning clutch ([page 9-5](#)).

Check the pinion gear [3] for wear or damage and replace the over running clutch if necessary ([page 9-5](#)).

If the pinion gear is worn or damaged, the flywheel ring gear must be inspected.

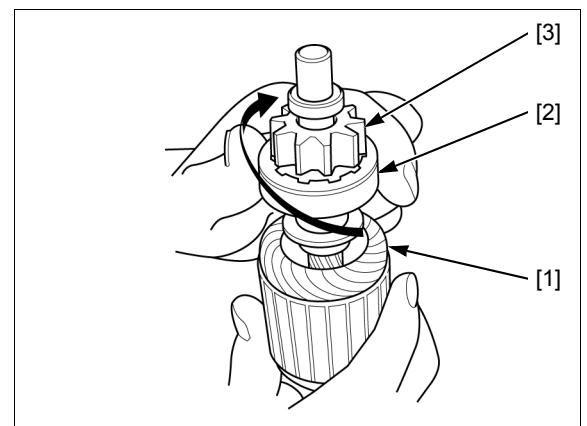

## STARTING SYSTEM

### MICA DEPTH

Clean the commutator, and then measure the mica depth.

### SERVICE LIMIT: 0.2 mm (0.01 in)

If the measurement is less than the service limit, replace the armature ([page 9-5](#)).

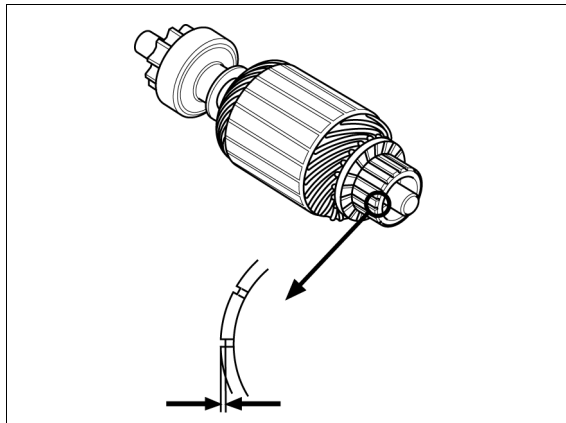

### ARMATURE CONTINUITY CHECK - COMMUTATOR SEGMENTS

Check for continuity between segments. If an open circuit (no continuity) exists between any two segments, replace the armature ([page 9-5](#)).

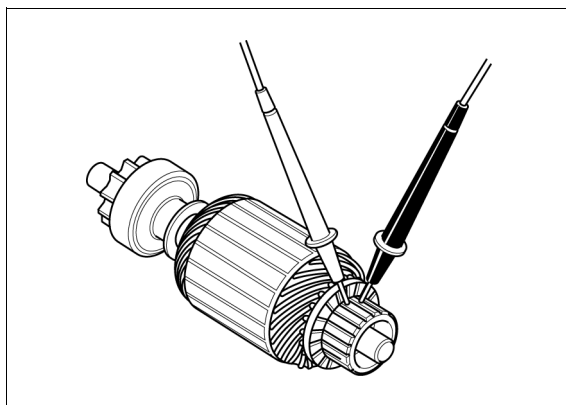

### ARMATURE CONTINUITY CHECK - COMMUTATOR TO CORE

Check for continuity between the commutator segments and the armature coil core.

Replace the armature if continuity exists between any of the commutator segments and the armature coil core ([page 9-5](#)).

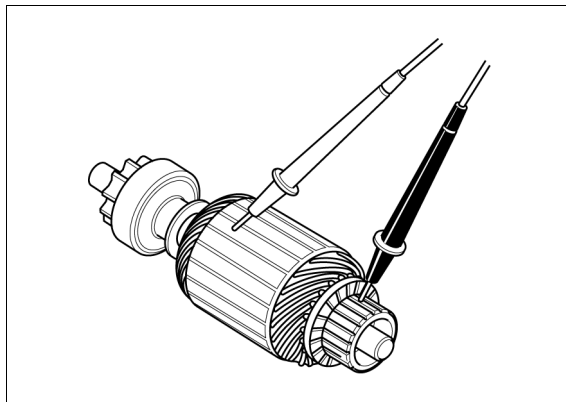

**ARMATURE CONTINUITY CHECK - COMMUTATOR TO SHAFT**

Check for continuity between the commutator and the armature shaft.

Replace the armature if continuity exists between any of the commutator segments and the armature shaft (page 9-5).

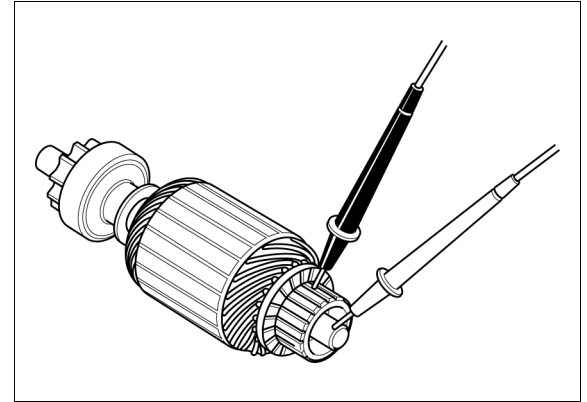

**BRUSH REPLACEMENT**

Cut off the brush lead [1] at the point shown and remove the brush [2].

Remove the remaining brush lead and deposited solder from the terminal.

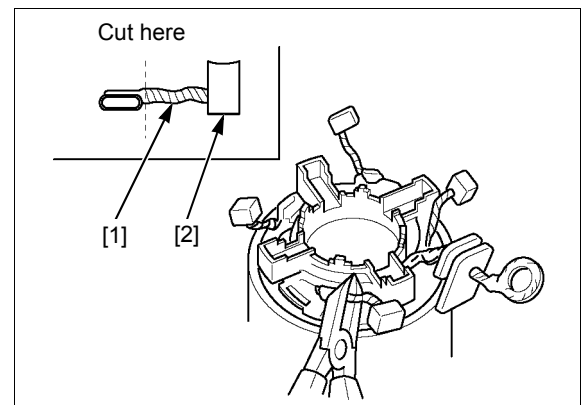

Hold a new brush [1] in the same direction of the removed brush and put a new plate [2] over the new brush and terminal [3] and press it using a pair of pliers as shown.

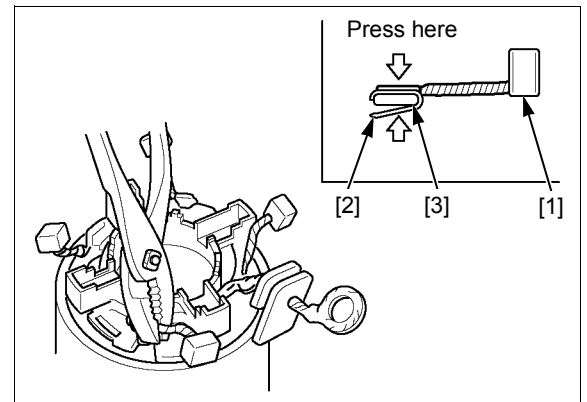

Solder the plate on the terminal.

- Before soldering, heat the pressed part of the plate well to make sure solder reaches the end of the pressed part.
- Prevent solder from flowing down the brush lead.
- Do not allow solder to run down onto the field winding of the yoke.
- File the brush so that the brush and commutator can fit using an emery paper #500 or #600.

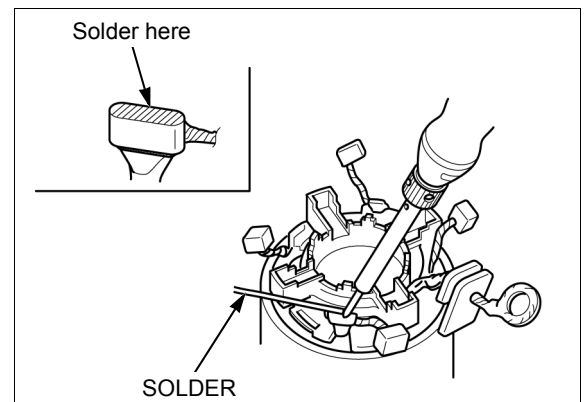

---

**MEMO**

---

# 10. OTHER ELECTRICAL

---

ECU.....	10-2	CONTROL BOX .....	10-6
RELAY .....	10-2	COMBINATION SWITCH INSPECTION.....	10-8
FUSE.....	10-3	HOUR METER INSPECTION.....	10-8
CKP SENSOR .....	10-3	INDICATOR INSPECTION .....	10-8
TE SENSOR .....	10-4	RESISTOR INSPECTION .....	10-9
OIL LEVEL SWITCH .....	10-5	SPEED VOLUME SWITCH INSPECTION.....	10-9

## ECU

### REMOVAL/INSTALLATION

Disconnect the battery negative (-) cable.

Disconnect the 18P (Black) [1] and 18P (Gray) [2] connectors.

Remove the bolts [3] and ECU [4].

Installation is in the reverse order of removal.

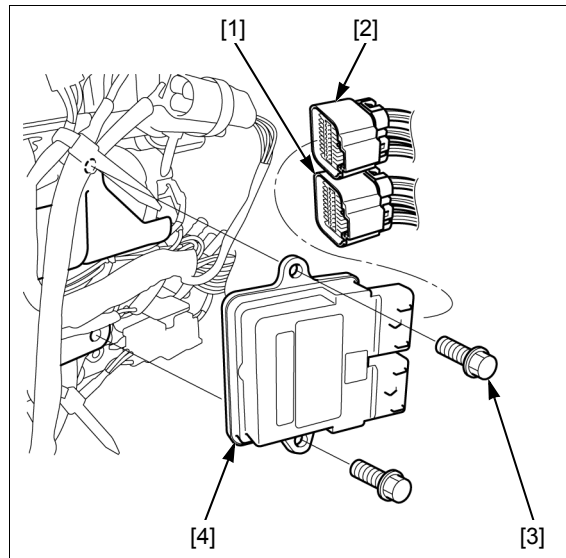

## RELAY

### REMOVAL/INSTALLATION (REMOTE TYPE)

Remove the suspensions [1] from the relay bracket [2].

Remove the FI relay [3] and MAIN relay [4] from the suspensions.

Remove the relays from the connectors [5].

Remove the screws [6] and bracket.

Installation is in the reverse order of removal.

**TORQUE: 5.0 N·m (0.5 kgf·m, 3.7 lbf·ft)**

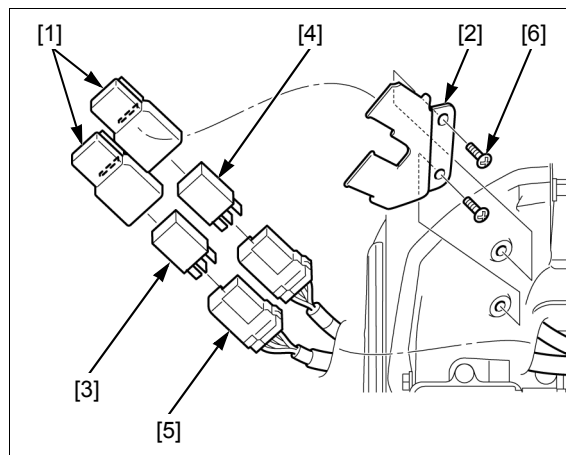

### INSPECTION

Connect an ohmmeter to the relay [1] terminals.

Connect a 12 V battery to the relay connector terminals as shown.

There should be continuity only when 12 V battery is connected.

If there is no continuity when the 12 V battery is connected, replace the relay.

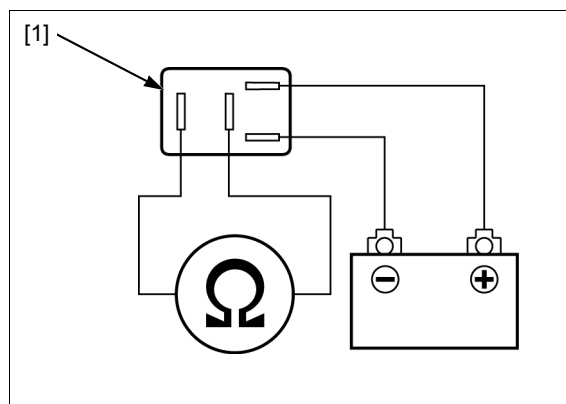

## FUSE

### REMOVAL/INSTALLATION (REMOTE TYPE)

Remove the covers [1] and fuses [2].

Installation is in the reverse order of removal.

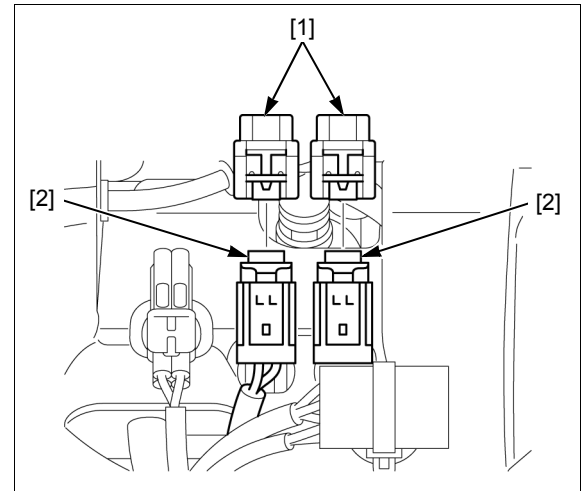

### INSPECTION

Check for blown fuse.

Replace the fuse if necessary.

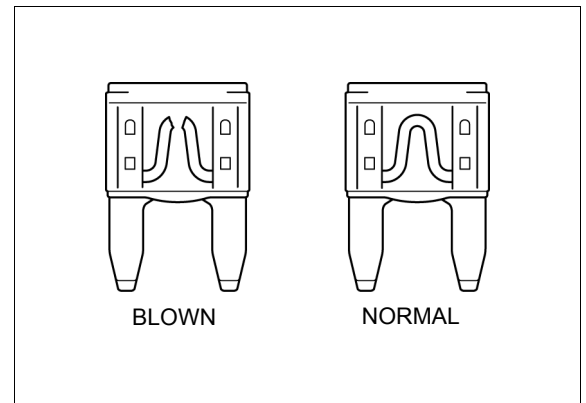

## CKP SENSOR

### REMOVAL/INSTALLATION

Remove the fan cover (page 5-2).

Disconnect the connector [1].

Remove the bolts [2] and CKP sensor [3].

Installation is in the reverse order of removal.

Insert the thickness gauge of proper thickness between the CKP sensor and the flywheel.

**STANDARD: 0.2 – 1.0 mm (0.01 – 0.04 in)**

If the clearance is out of specification, check the CKP sensor, mounting boss, or related parts and replace it if necessary.

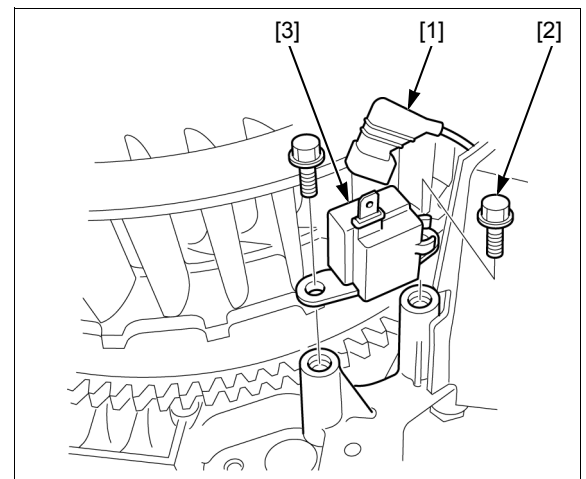



## OTHER ELECTRICAL

### INSPECTION

Measure the resistance between the terminals and sensor body.

**STANDARD: 216 – 264  $\Omega$**

Replace the CKP sensor if the measurement is out of specification ([page 10-3](#)).

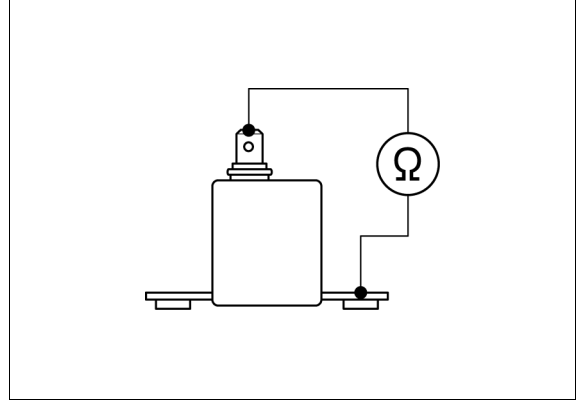

## TE SENSOR

### REMOVAL/INSTALLATION

Disconnect the 2P connector [1] and remove the TE sensor [2].

Install and tighten the TE sensor to the specified torque.

**TORQUE: 12 N·m (1.2 kgf·m, 9.0 lbf·ft)**

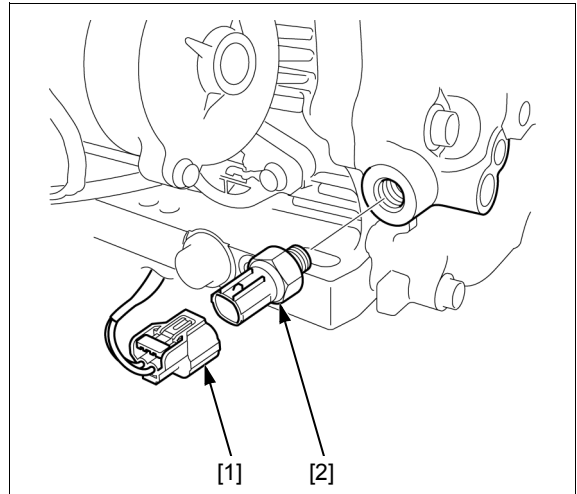

### INSPECTION

Heat the coolant with an electric heating element.

Suspend the TE sensor [1] in the heated coolant and measure the resistance through the sensor as the coolant heats up.

NOTE:

- Wear insulated gloves and adequate eye protection. Keep flammable materials away from the electric heating element.
- Soak the sensor in coolant up to its threads with at least 40 mm (1.57 in) from the bottom of the pan to the bottom of the sensor.
- Keep temperature constant for 3 minutes before testing. A sudden change of temperature will result in incorrect readings. Do not let the thermometer [2] or sensor touch the pan.

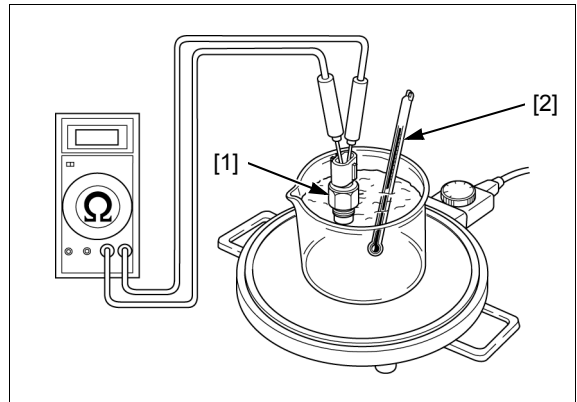

<b>Temperature:</b>	<b>40 °C (104 °F)</b>	<b>100 °C (212 °F)</b>
<b>Resistance:</b>	<b>1.1 – 1.4 k<math>\Omega</math></b>	<b>0.1 – 0.3 k<math>\Omega</math></b>

Replace the TE sensor if the measurements are out of specification ([page 10-4](#)).

## OIL LEVEL SWITCH

### REMOVAL/INSTALLATION

- Drain the engine oil completely ([page 3-4](#)).
- Disconnect the connector [1].
- Remove the bolts [2] and oil level switch [3].
- Installation is in the reverse order of removal.

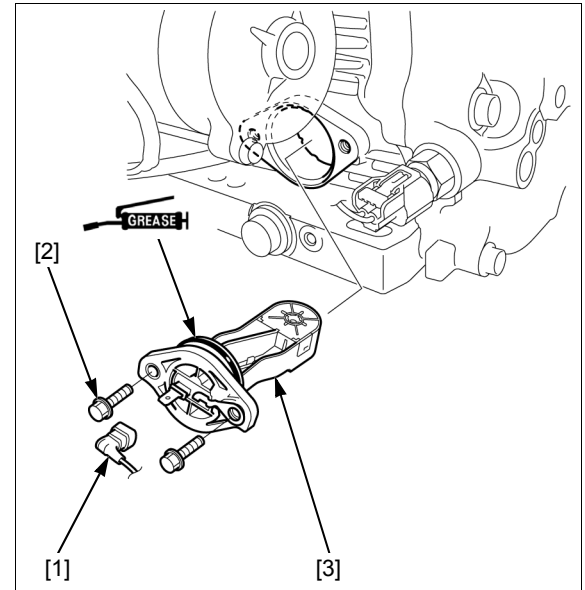

### INSPECTION

- Disconnect the connector from the oil level switch.
- Check for continuity between the switch terminal and ground.
- There should be no continuity when the engine is full of oil.
- Drain the engine oil completely ([page 3-4](#)).
- Check for continuity between the switch terminal and ground.
- There should be continuity.
- Check continuity between the switch terminal and ground while filling with the engine oil.
- The ohmmeter reading should go from continuity to no continuity as the oil is filled.
- If the correct continuity is not obtained, replace the oil level switch ([page 10-5](#)).

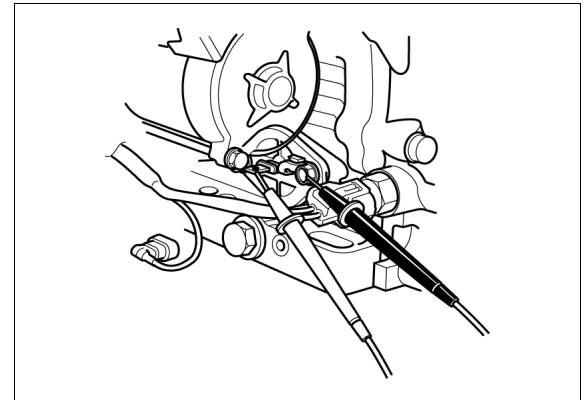

# CONTROL BOX

## REMOVAL/INSTALLATION

Remove the ECU (page 10-2).

- FUSE
- 17 A CHARGING COIL: 30 A
  - 26 A CHARGING COIL: 40 A

FUSE 15 A

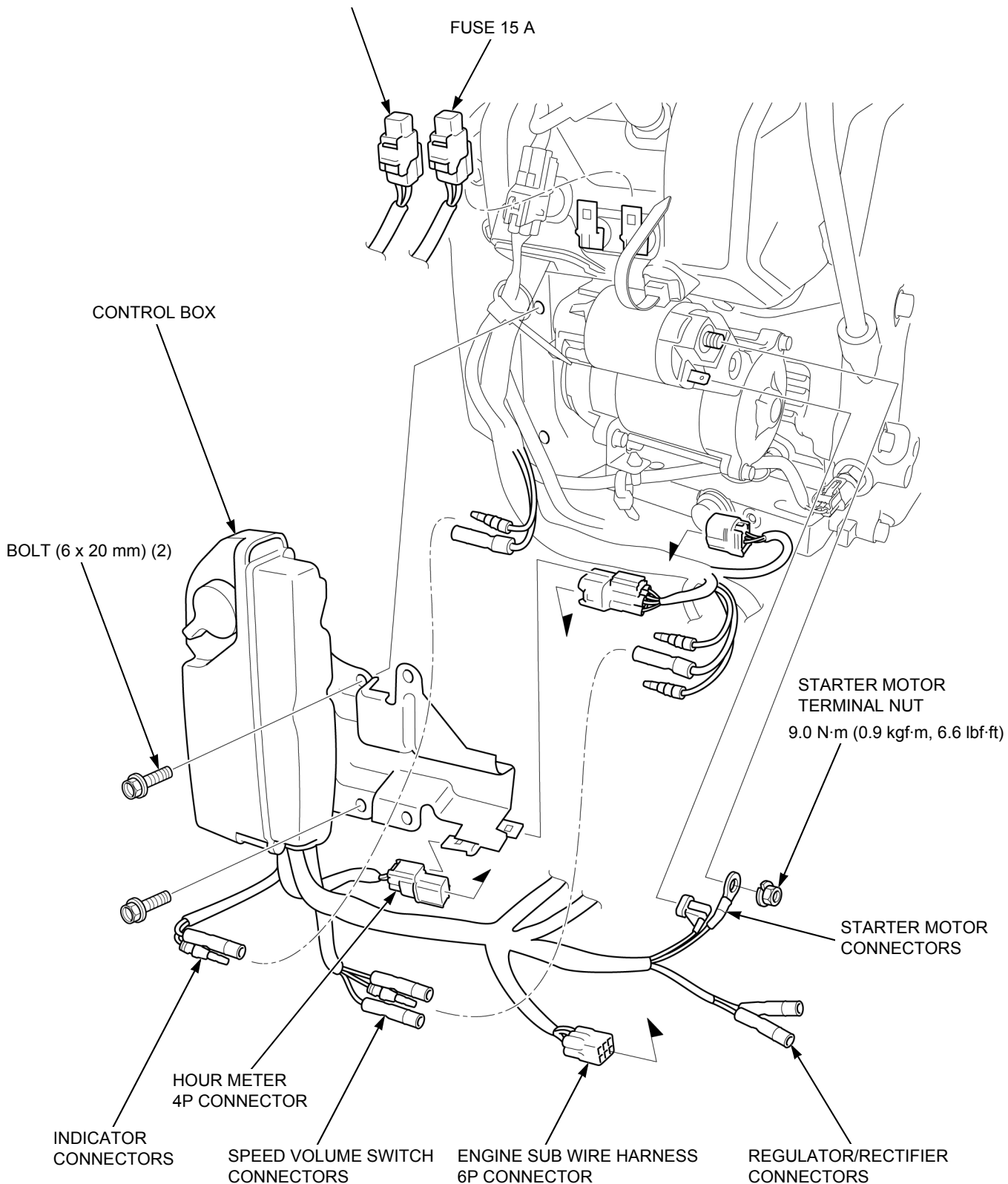

**DISASSEMBLY/ASSEMBLY**

Remove the control box (page 10-6).

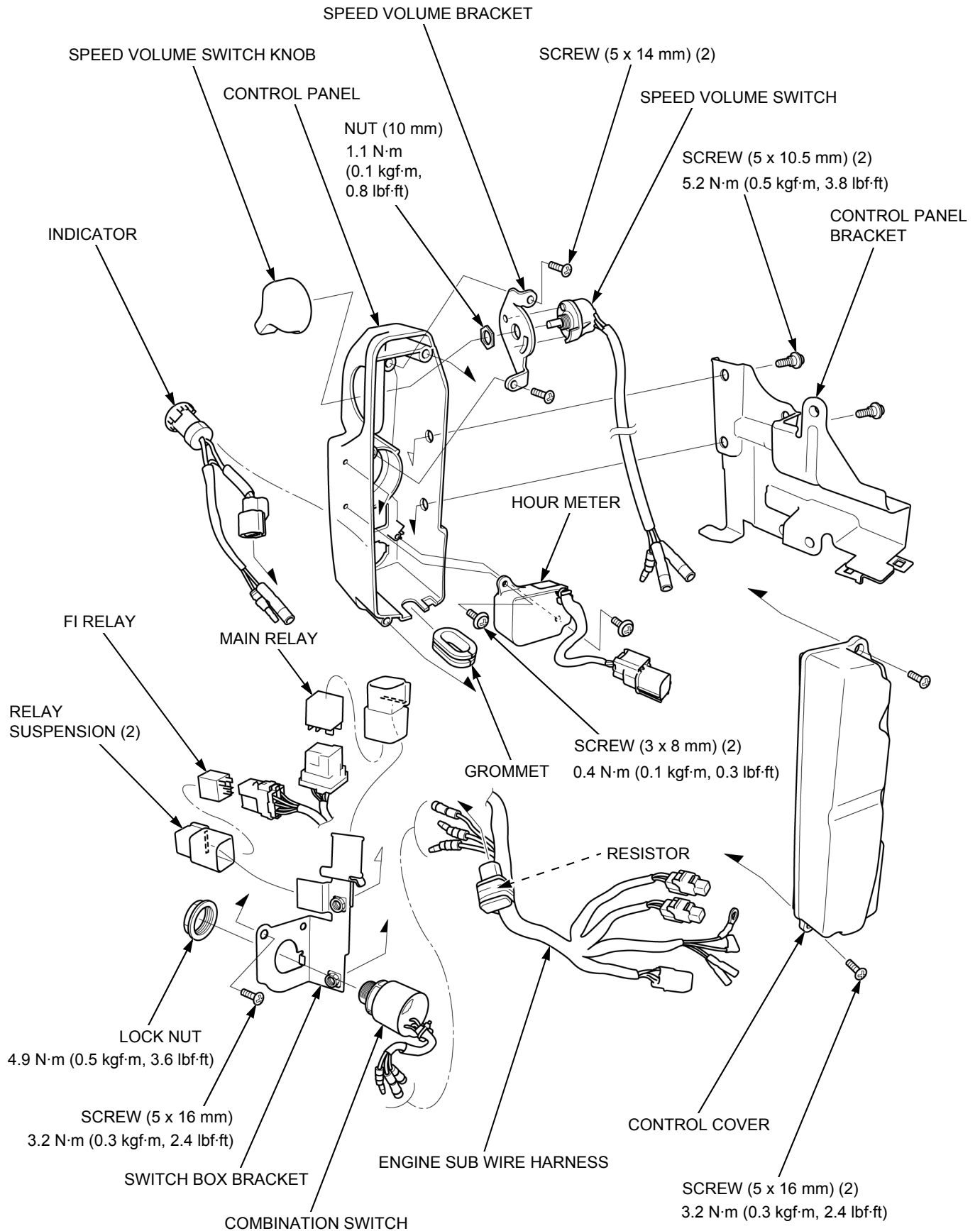

## COMBINATION SWITCH INSPECTION

Remove the combination switch (page 10-7).

Check continuity between the terminals at each switch position.

If the correct continuity is not obtained, replace the combination switch (page 10-7).

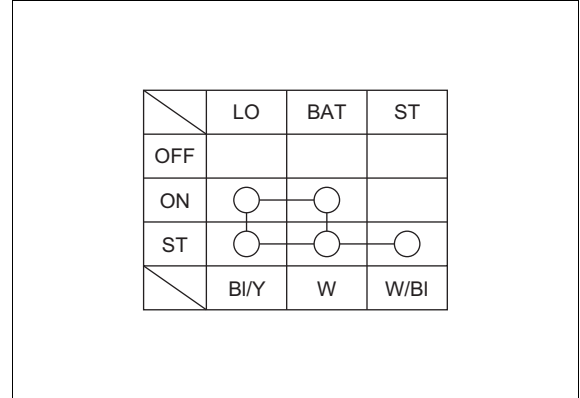

## HOUR METER INSPECTION

Remove and 4P connector [1] (page 10-6).

Apply a 12 V battery voltage between the W/BI terminal and G terminal at hour meter side.

**Connection: W/BI (+) – G (–)**

Connect the battery (+) to the Y terminal.

The hour meter should start counting time.

Disconnect the battery (+) from the Y terminal.

The hour meter should stop counting time.

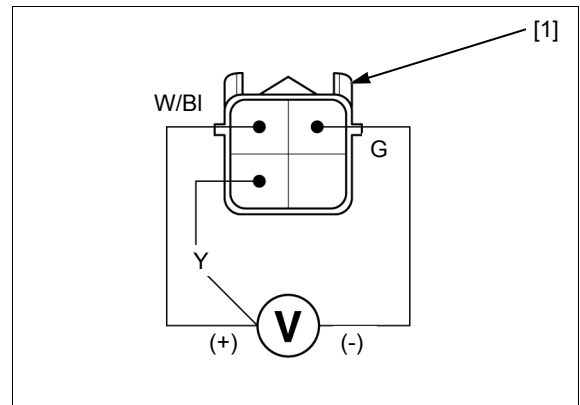

## INDICATOR INSPECTION

Inspect the resistor (page 10-9).

Disconnect the indicator connectors (page 10-6).

Apply a 12 V battery voltage between the BI/Y (+) connector [1] and R/Bu (–) connector [2].

**Connection: BI/Y (+) – R/Bu (–)**

If the not indicated, replace the indicator (page 10-7).

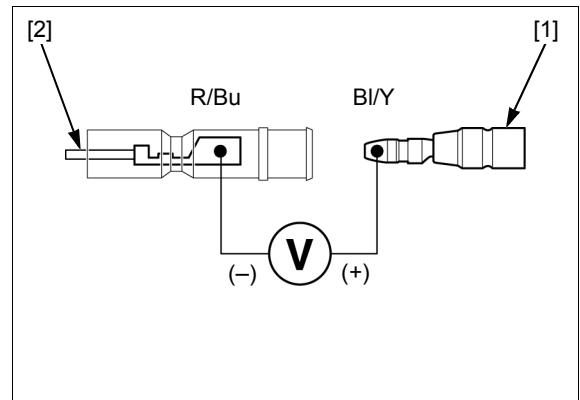

## RESISTOR INSPECTION

Disconnect the resistor connector (page 10-7).

Check for continuity between the resistor [1] terminals.

**STANDARD: 3.0 k $\Omega$**

Replace the resistor if the measurement is out of specification (page 10-7).

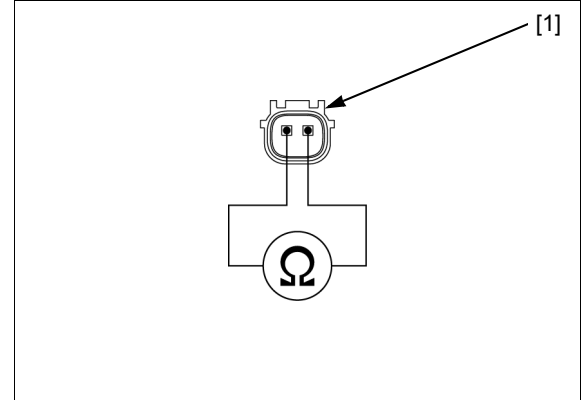

## SPEED VOLUME SWITCH INSPECTION

### SPEED VOLUME DOES NOT FUNCTION

#### 1. INPUT VOLTAGE INSPECTION

Turn the combination switch OFF.

Disconnect the speed volume switch connectors (page 10-6).

Turn the combination switch ON.

Measure the voltage between the engine wire harness side Br wire connector [1] and G wire connector [2].

**Connection: Br (+) – G (-)**

**Is there 4.9 – 5.1 V?**

**YES** – GO TO STEP 5.

**NO** – GO TO STEP 2.

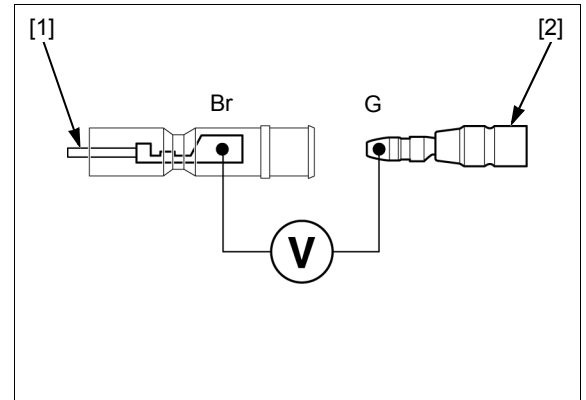

#### 2. POWER LINE OPEN CIRCUIT INSPECTION

Turn the combination switch OFF.

Disconnect the ECU 18P (Black) connector (page 10-2).

Check for continuity between the engine wire harness side Br wire connector [1] and 18P (Black) connector [2].

**Connection: Br – 16**

**Is there continuity?**

**YES** – GO TO STEP 3.

**NO** – Open circuit in Br wire

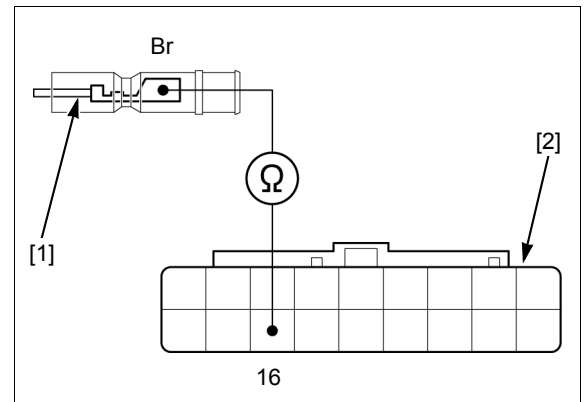

## OTHER ELECTRICAL

### 3. POWER LINE SHORT CIRCUIT INSPECTION

Check for continuity between the engine wire harness side Br wire connector [1] at the wire side and ground.

**Connection: Br – Ground**

**Is there continuity?**

**YES** – Short circuit in Br wire

**NO** – GO TO STEP 4.

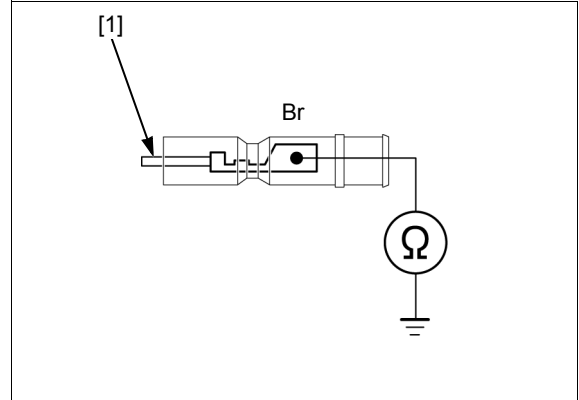

### 4. GROUND LINE OPEN CIRCUIT INSPECTION

Check for continuity between the engine wire harness side G wire connector [1] and 18P (Black) connector [2].

**Connection: G – 10**

**Is there continuity?**

**YES** – Replace the ECU with a known good one ([page 10-2](#)), and recheck.

**NO** – Open circuit in G wire

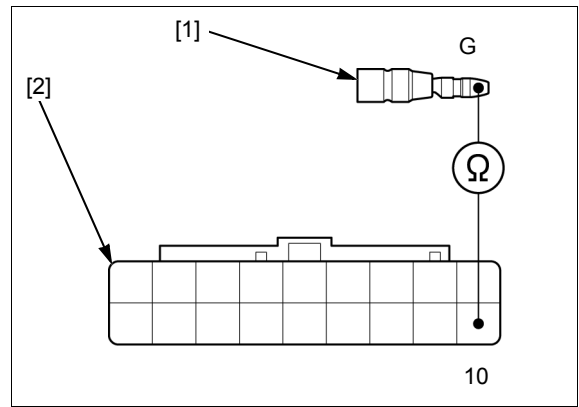

### 5. SIGNAL LINE OPEN CIRCUIT INSPECTION

Turn the combination switch OFF.

Disconnect the ECU 18P (Gray) connector ([page 10-2](#)).

Check for continuity between the engine wire harness side R wire connector [1] and 18P (Gray) connector [2].

**Connection: R – 13**

**Is there continuity?**

**YES** – GO TO STEP 6.

**NO** – Open circuit in R wire

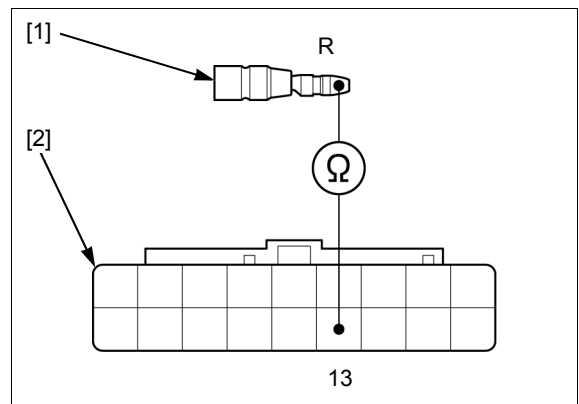

### 6. SIGNAL LINE SHORT CIRCUIT INSPECTION

Check for continuity between the engine wire harness side R wire connector [1] and ground.

**Connection: R – Ground**

**Is there continuity?**

**YES** – Short circuit in R wire

**NO** – GO TO STEP 7.

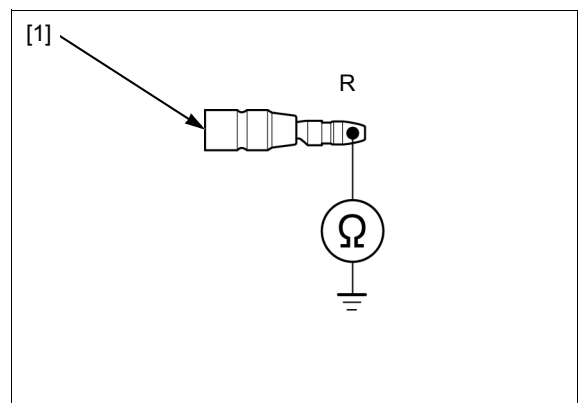

**7. SPEED VOLUME SWITCH INSPECTION**

Replace the speed volume switch with a known good one ([page 10-7](#)).

Check the speed volume function.

***Does the speed volume function properly?***

**YES** – Faulty original speed volume switch

**NO** – Replace the ECU with a known good one ([page 10-2](#)), and recheck.



---

**MEMO**

---

HIGH MOUNT MUFFLER.....11-2

STUD BOLT REPLACEMENT ..... 11-3

# MUFFLER

## HIGH MOUNT MUFFLER

### ⚠ CAUTION

The muffler becomes very hot during operation and remains hot for a while after stopping the engine. Be careful not to touch the muffler while it is hot. Allow it to cool before proceeding.

### REMOVAL/INSTALLATION

MUFFLER PROTECTOR

INSTALLATION:  
Install with the "HOT" mark facing up.

BOLT (6 x 8 mm) (6)

HOT MARK

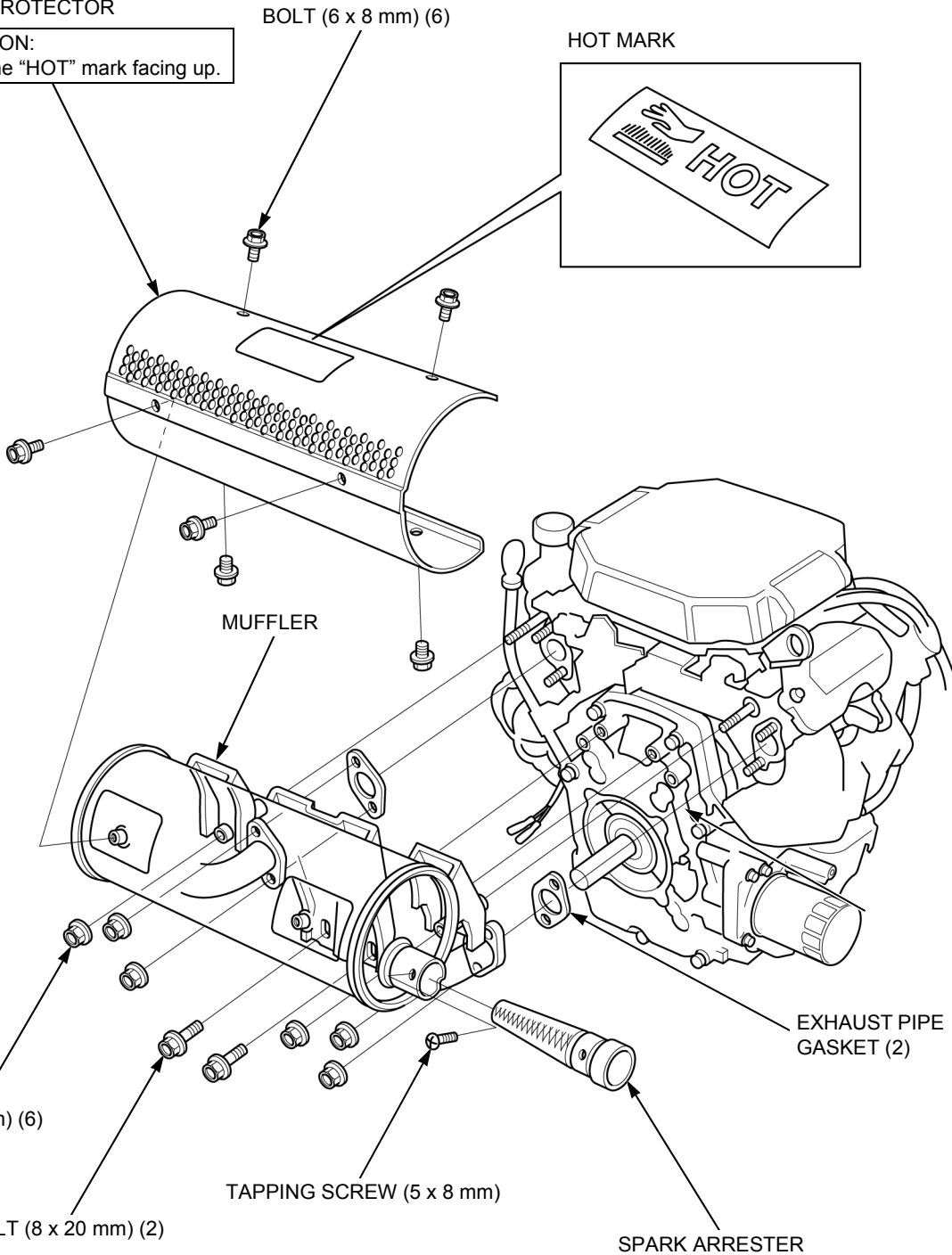
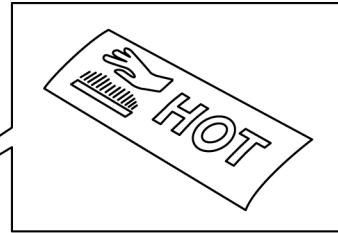

## STUD BOLT REPLACEMENT

Thread two nuts onto the stud bolt and tighten them together, then use a wrench to turn the stud bolt out.

Install new stud bolts.

**SPECIFIED LENGTH:**

**High mount muffler mounting stud bolt:**

**No.1 cylinder: 60 mm (2.4 in)**

**No.2 cylinder: 45 mm (1.8 in)**

**Exhaust pipe mounting stud bolt:**

**21 mm (0.8 in)**

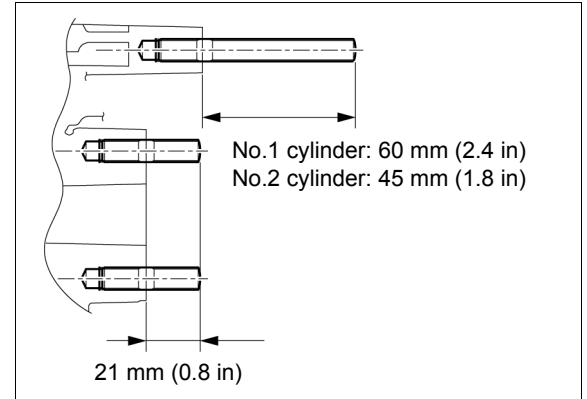

---

**MEMO**

---

# 12. LUBRICATION SYSTEM

---

LUBRICATION SYSTEM DIAGRAM .....	12-2	OIL PUMP INSPECTION .....	12-5
OIL PRESSURE SWITCH .....	12-3	OIL COOLER (GX800IRH ONLY).....	12-6
OIL PRESSURE TEST .....	12-4		

LUBRICATION SYSTEM DIAGRAM

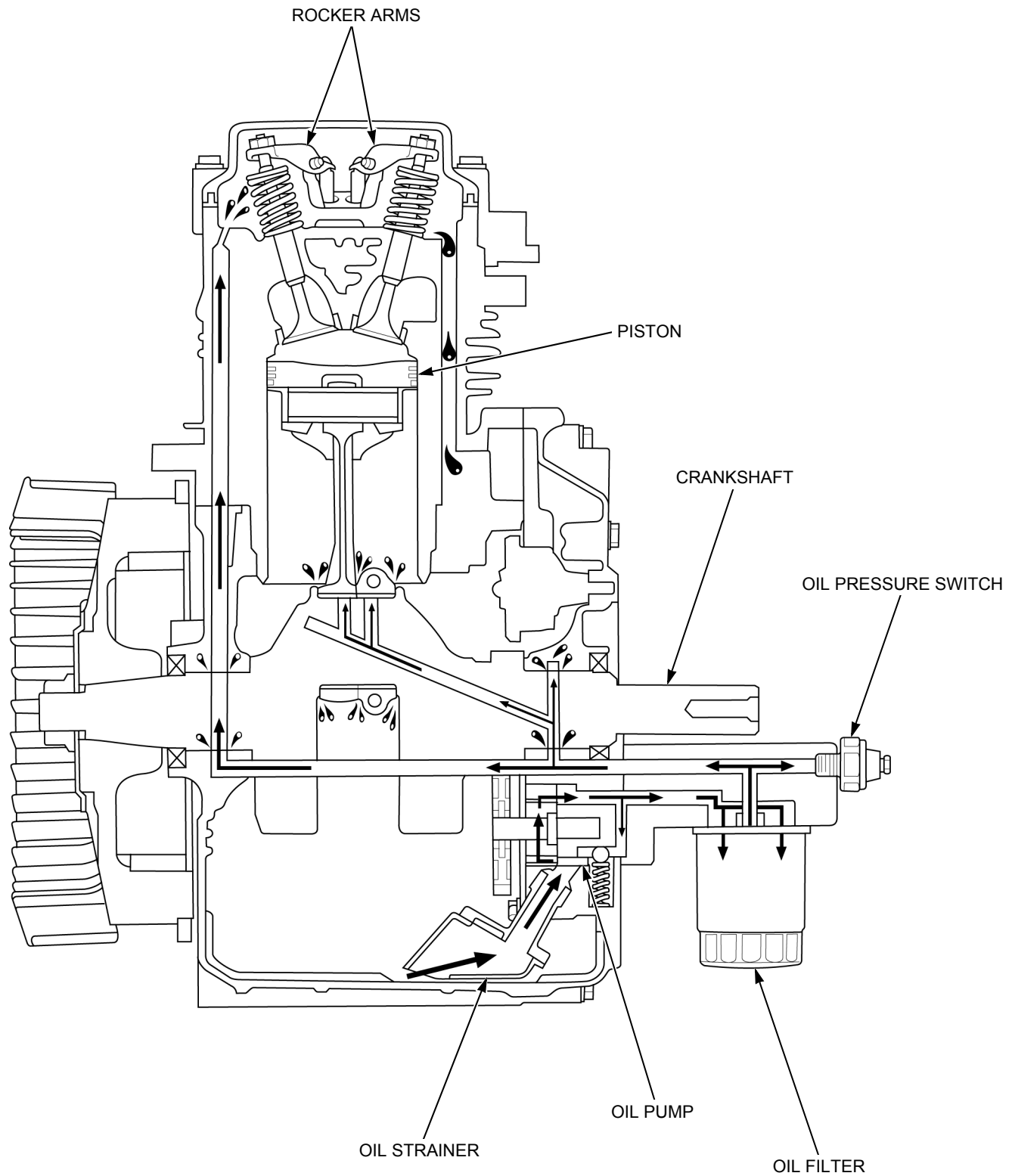

## OIL PRESSURE SWITCH

### REMOVAL

Remove the screw [1], wire terminal [2], and oil pressure switch [3] or sealing plug [4].

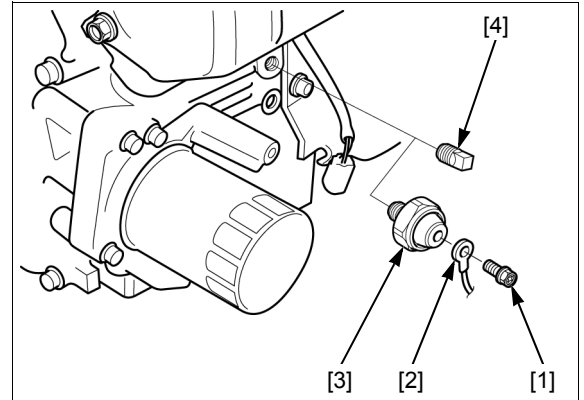

### INSTALLATION

Clean the oil pressure switch or sealing bolt threads, and apply liquid sealant (threebond 1207B, 1141G, 1215) to the threads as shown.

Install and tighten the oil pressure switch to the specified torque.

**TORQUE: 9.0 N·m (0.9 kgf·m, 6.6 lbf·ft)**

#### NOTICE

*Do not apply liquid sealant to the tip of the threads.*

*Tighten the oil pressure switch or sealing bolt to the specified torque. Do not overtighten the attachment to avoid damaging the crankcase threads.*

Install the wire terminal and screw and tighten the screw.

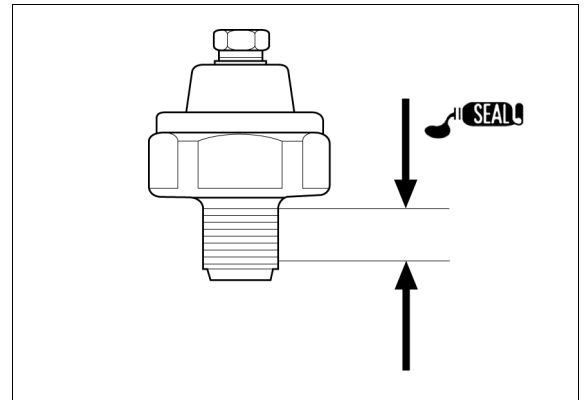

### INSPECTION

With the combination switch OFF, check continuity between the switch terminal and switch body.

There should be continuity.

Start the engine and check continuity between the switch terminal and switch body.

There should be no continuity.

If the correct continuity is not obtained, replace the oil pressure switch ([page 12-3](#)).

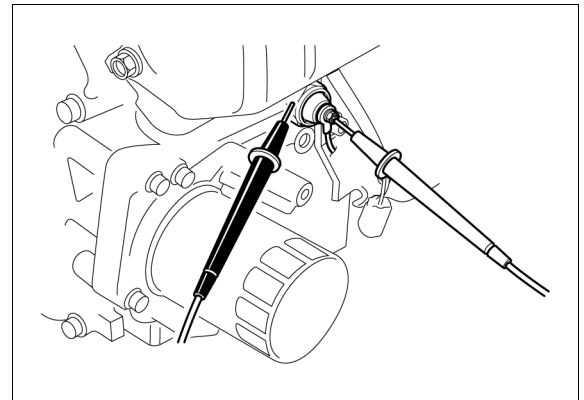



### OIL PRESSURE TEST

Check the engine oil level ([page 3-3](#)).

Temporarily remove the fuel pump (high pressure side) ([page 6-14](#)).

Remove the oil pressure switch or sealing plug ([page 12-3](#)).

Install commercially available oil pressure gauge and adapter.

**TOOLS (commercially available):**

**Oil pressure gauge attachment [1]**

**Oil pressure gauge [2]**

**TORQUE: 9.0 N·m (0.9 kgf·m, 6.6 lbf·ft)**

#### NOTICE

*Tighten the oil pressure gauge attachment to the specified torque. Do not overtighten the attachment to avoid damaging the crankcase threads.*

Install the fuel pump (high pressure side) ([page 6-14](#)).

Start the engine and confirm that the engine has oil pressure.

Allow engine to warm up for 10 minutes.

While the engine is at idle, measure the oil pressure.

**OIL PRESSURE:**

**2.8 kgf/cm<sup>2</sup> (39.8 psi) / 2,000 rpm or more**

If the oil pressure is less than the specification, inspect the oil pump ([page 12-5](#)).

Remove the special tools.

Install the oil pressure switch ([page 12-3](#)).

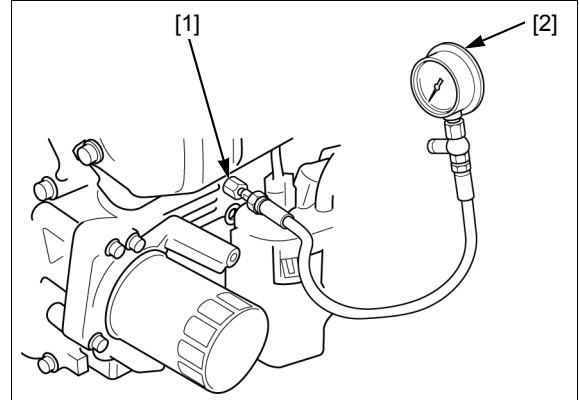

## OIL PUMP INSPECTION

### OIL PUMP TIP CLEARANCE

Remove the crankcase cover (page 14-2).

Remove the oil pump cover (page 14-7).

Measure the oil pump rotor tip clearance.

**STANDARD:** 0.15 mm (0.006 in)

**SERVICE LIMIT:** 0.30 mm (0.012 in)

If the measurement is more than the service limit, replace the inner rotor and outer rotor (page 14-7).

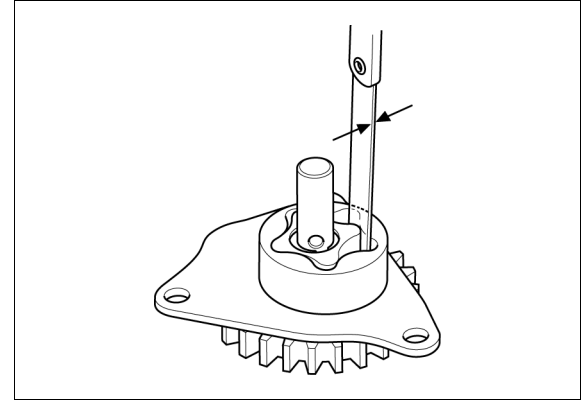

### OUTER ROTOR-TO-HOUSING CLEARANCE

Remove the crankcase cover (page 14-2).

Remove the oil pump cover (page 14-7).

Measure the oil pump outer rotor-to-housing clearance.

**STANDARD:** 0.150 – 0.210 mm  
(0.0059 – 0.0083 in)

**SERVICE LIMIT:** 0.30 mm (0.012 in)

If the measurement is more than the service limit, replace the outer rotor (page 14-7).

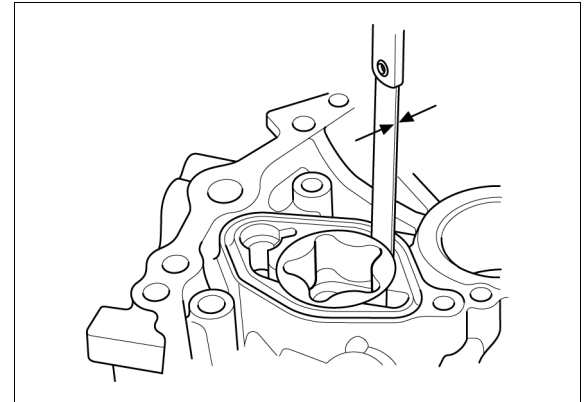

### OUTER ROTOR-TO-PUMP COVER CLEARANCE

Remove the crankcase cover (page 14-2).

Remove the oil pump cover and oil pump O-ring (page 14-7).

Measure the oil pump outer rotor-to-pump cover clearance.

**STANDARD:** 0.04 – 0.09 mm (0.002 – 0.004 in)

**SERVICE LIMIT:** 0.11 mm (0.004 in)

If the measurement is more than the service limit, replace the outer rotor (page 14-7).

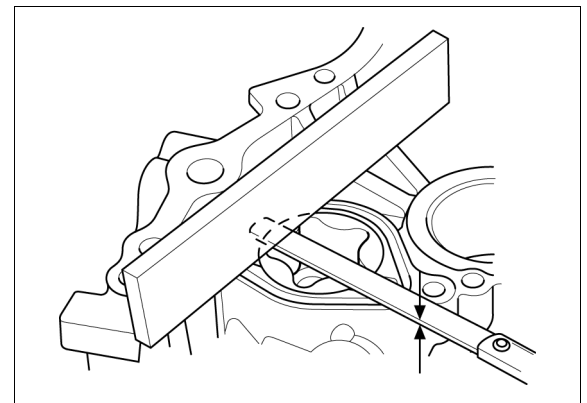

# OIL COOLER (Applicable Types)

## REMOVAL/INSTALLATION

Drain the engine oil ([page 3-4](#)).

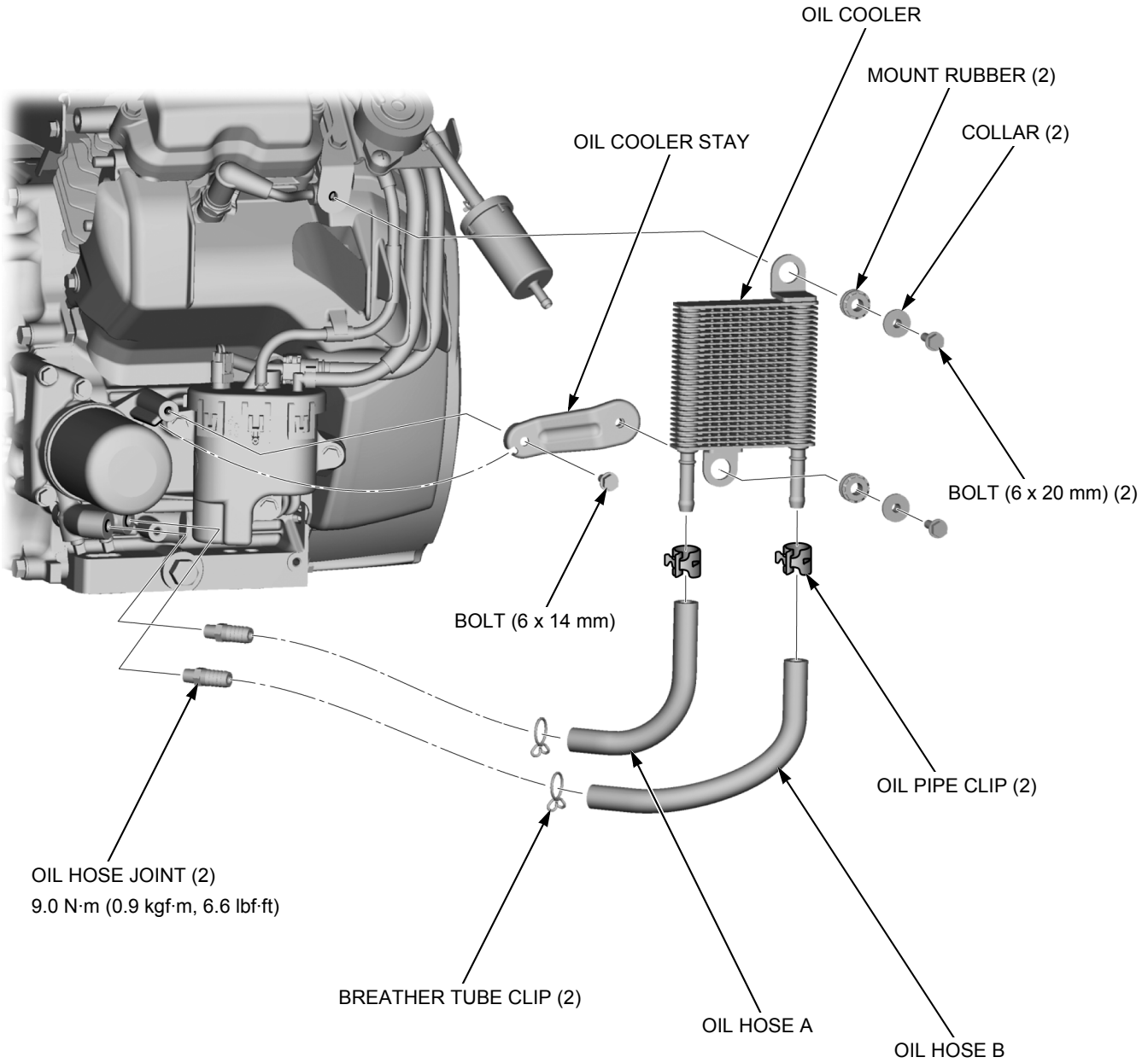

CYLINDER/PISTON REMOVAL .....	13-2	PISTON DISASSEMBLY/ASSEMBLY .....	13-6
PISTON INSTALLATION .....	13-3	CYLINDER/PISTON INSPECTION .....	13-7
CYLINDER INSTALLATION .....	13-3	VALVE SEAT RECONDITIONING.....	13-14
CYLINDER DISASSEMBLY/ASSEMBLY ...	13-5		

# CYLINDER

## CYLINDER/PISTON REMOVAL

Set the piston at the top dead center of the cylinder compression stroke (page 3-8).

Remove the following parts:

- Air cleaner (page 6-12)
- Throttle body (page 6-16)
- Muffler (page 11-2)
- Fan cover (page 5-2)
- L./R. lower shrouds (page 5-3)
- Ignition coil (page 8-3)
- Starter motor (page 9-4)
- Oil level pipe (page 14-2).
- Head cover (page 3-8).

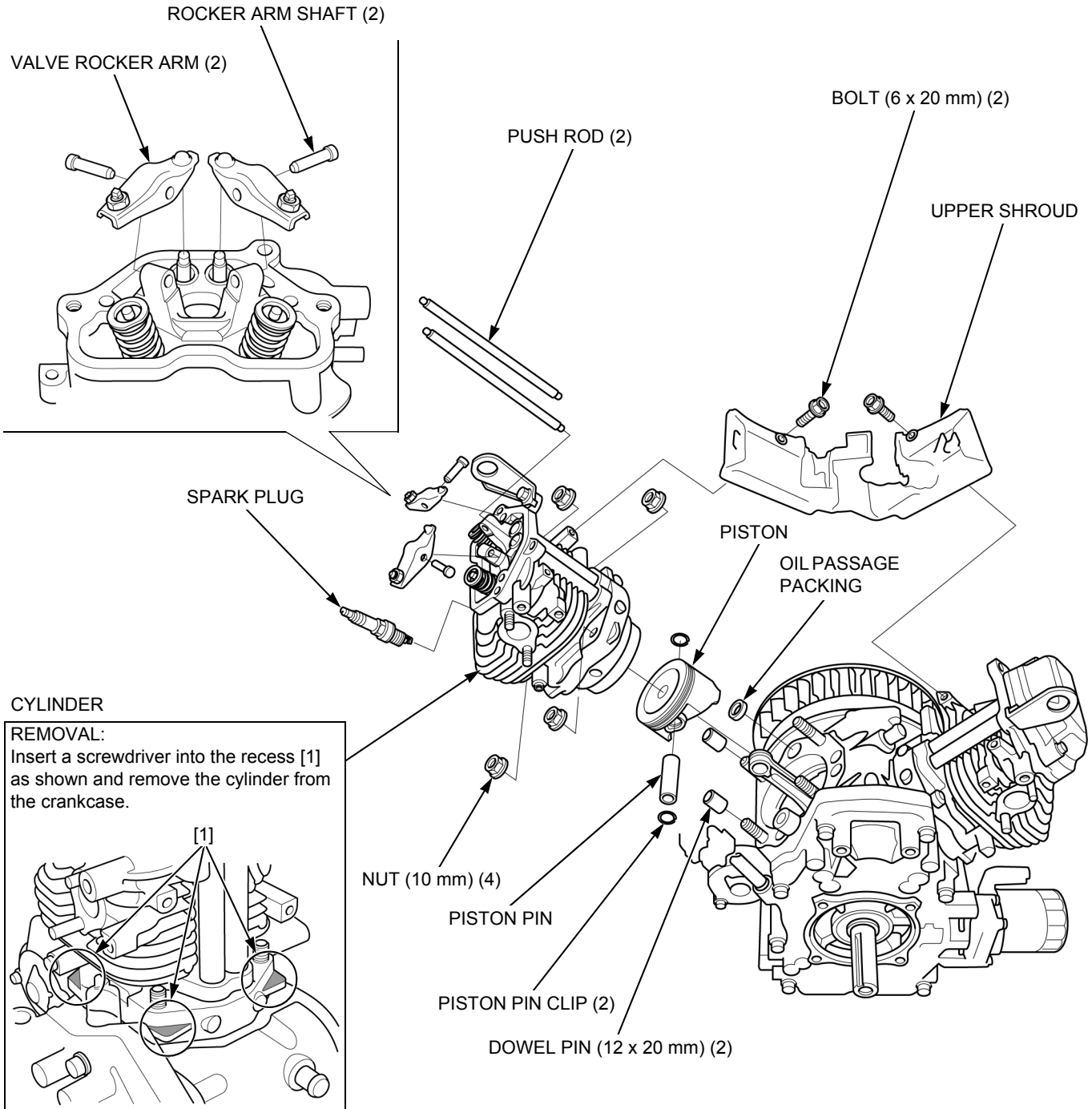

## PISTON INSTALLATION

Position the connecting rod of the cylinder near top dead center by rotating the crankshaft slowly.

Install the piston [1] on the connecting rod [2] with triangle mark [3] of the piston pointing toward the flywheel side as shown.

Apply molybdenum oil solution to the outer surface of the piston pin [4].

Apply engine oil to the connecting rod small end and piston pin bore.

Install the piston pin through the piston and connecting rod.

Install new piston pin clips [5] into the grooves in the piston pin bore.

- Make sure the piston pin clips are seated securely.
- Do not align the piston pin clip end gap [6] with the piston cutout [7].

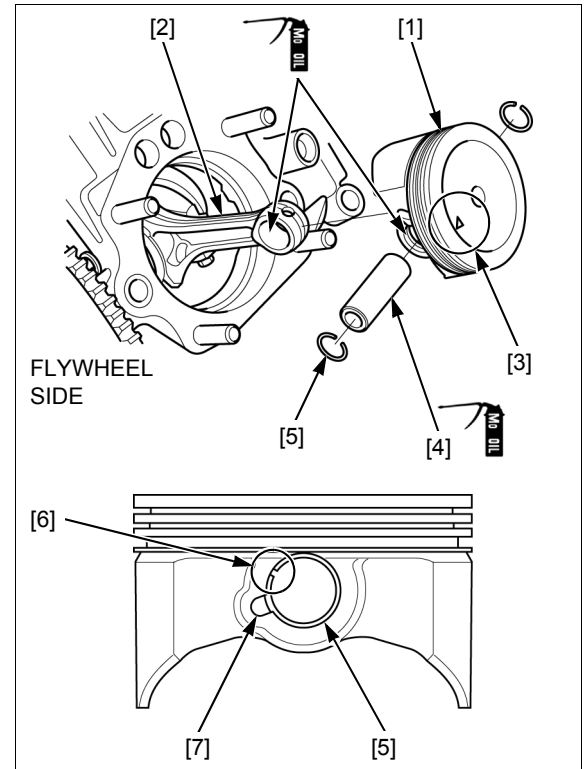

## CYLINDER INSTALLATION

Clean the mating surfaces of the cylinder and crankcase of old liquid gasket, oil and other foreign material.

Loosely install the fan cover and set the piston near top dead center by rotating the crankshaft slowly (page 3-8).

Apply a bead ( $\Phi 1.0 - 1.5$  mm ( $\Phi 0.04 - 0.06$  in)) of liquid gasket (Threebond TB1207B) to the mating surface of the cylinder as shown.

### NOTE:

- Spread enough sealant especially on the bold line area to secure the seal.

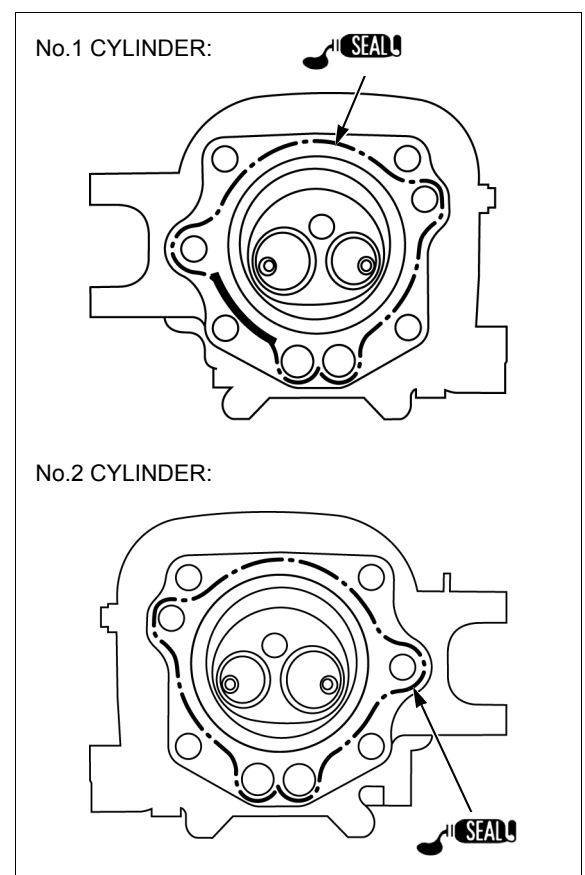

## CYLINDER

Apply grease to the oil passage packing [1].

Install the dowel pins [2] and oil passage packing on the crankcase.

Apply oil to the piston outer surface.

Apply molybdenum oil to the cylinder inner surface and piston rings.

Install the cylinder [3] over the piston [4] while compressing the piston rings with your fingers.

Apply a light coat of oil to the threads and the seating surface of the four flange nuts [5] and tighten them to the specified torque.

**TORQUE: 37 N·m (3.8 kgf·m, 27 lbf·ft)**

- Assemble the cylinder within 3 minutes after applying liquid gasket.
- Wait for 30 minutes after assembly before filling with oil and starting the engine.

Apply oil to the both ends of the two push rods [6] and insert them into the cylinder.

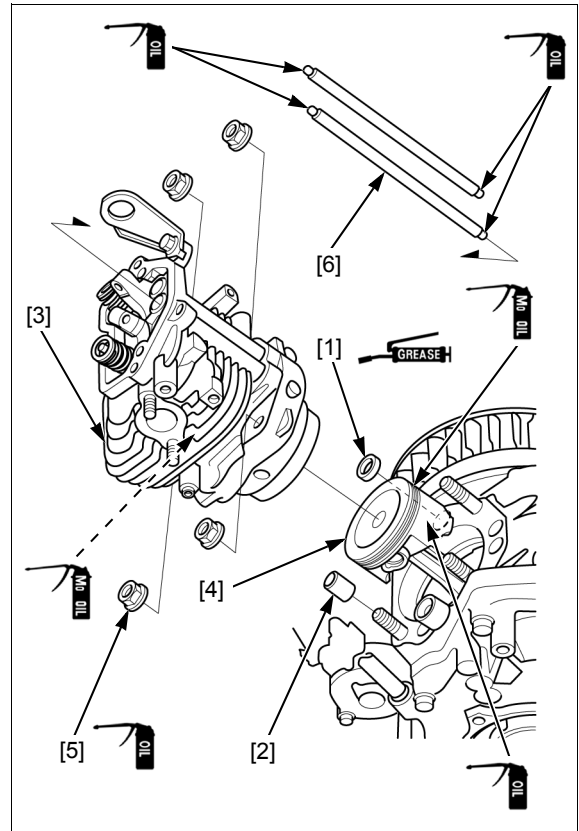

Apply oil to the bearing and slipper of the rocker arms [1] and install them to the cylinder.

Apply oil to the rocker arm shafts [2] and insert them into the cylinder in the direction as shown.

Install the head cover ([page 3-8](#)).

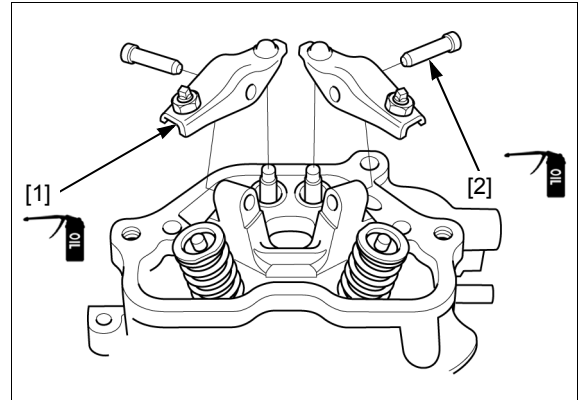

# CYLINDER DISASSEMBLY/ASSEMBLY

Remove the cylinder (page 13-2).

VALVE SPRING RETAINER (2)

**DISASSEMBLY:**  
 Push down and slide the valve spring retainer [1] to the side so that the valve stem [2] slips through the hole at side of the valve spring retainer.  
 Do not remove the valve spring retainer while the cylinder is installed to the crankcase, or the valve will drop into the cylinder.

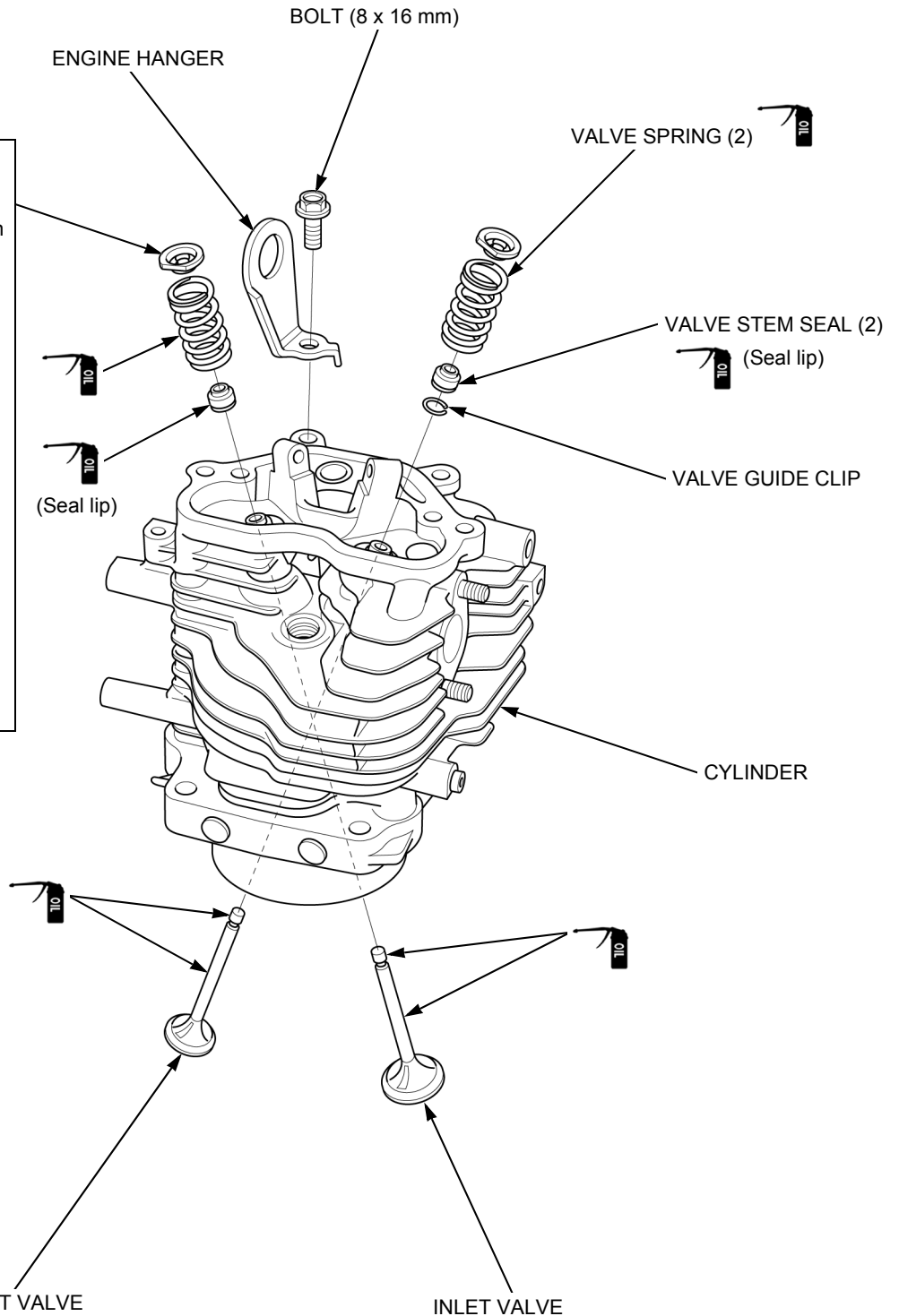
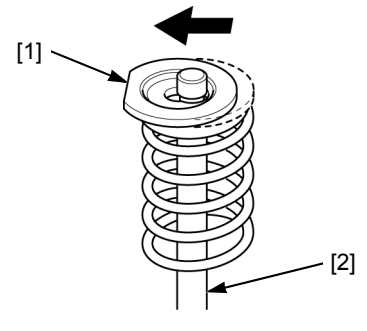

**ASSEMBLY:**  
 Do not interchange with the exhaust valve.  
 The inlet valve is larger than the exhaust valve.

**ASSEMBLY:**  
 Do not interchange with the inlet valve.  
 The exhaust valve is smaller than the inlet valve.



# PISTON DISASSEMBLY/ASSEMBLY

Remove the piston (page 13-2).

## PISTON RING SET

### ASSEMBLY:

The top ring [1] and second ring [2] are not interchangeable.

Install the top ring and second ring on the piston with the mark side facing up.

Check that the piston rings rotate smoothly after installing them.

Space the piston ring end gaps 120 degrees apart, and do not align the ring end gaps with the piston pin bore.

GX700IRH:

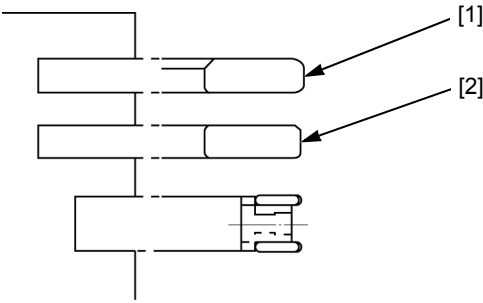

GX800IRH:

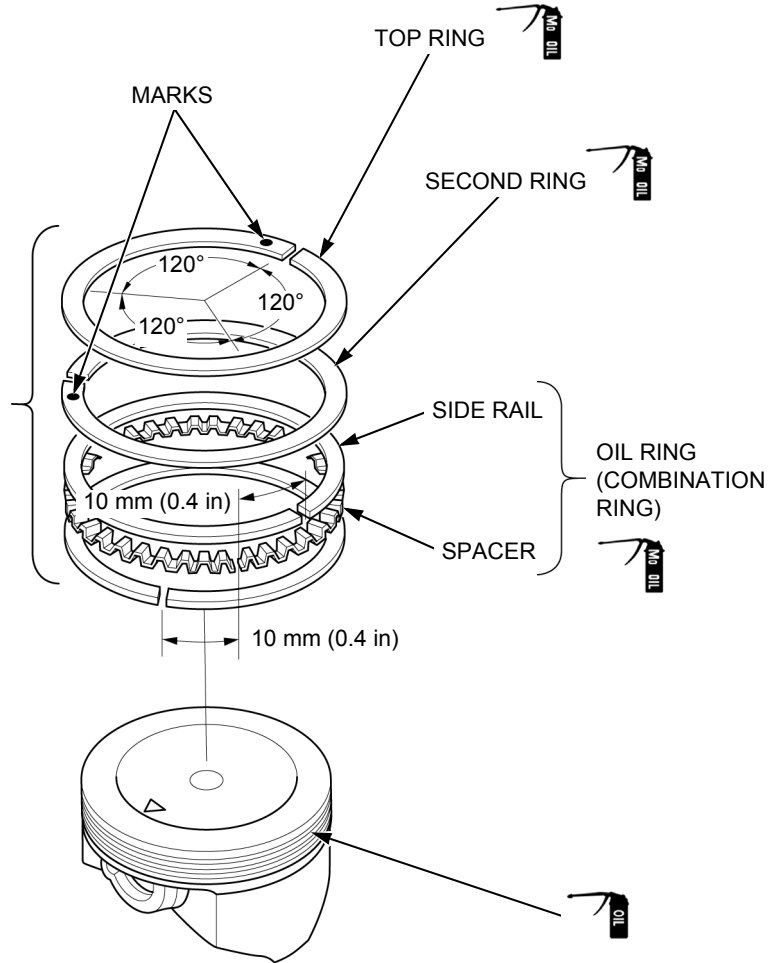
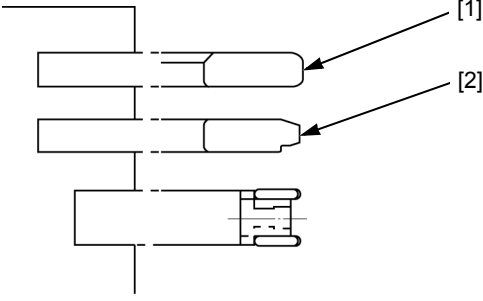

## CYLINDER/PISTON INSPECTION

### CYLINDER COMPRESSION CHECK

Start the engine and warm it up to normal operating temperature.

Remove the spark plugs (page 13-7).

Operate the starter motor to expel unburned gas.

Attach a commercially available compression gauge [1] to the spark plug hole.

Operate the starter motor to measure stable cylinder compression.

#### NOTICE

*Do not operate the starter motor for more than 5 seconds at a time. When operating the starter motor several times in a row, wait 10 – 20 seconds between operation to recover the battery voltage.*

#### GX700IRH:

##### CYLINDER COMPRESSION:

###### #1 CYLINDER

0.6 – 0.8 MPa (6.12 – 8.16 kgf/cm<sup>2</sup>, 87 – 116 psi)

500 rpm

###### #2 CYLINDER

0.4 – 0.6 MPa (4.08 – 6.12 kgf/cm<sup>2</sup>, 58 – 87 psi)

500 rpm

#### GX800IRH:

##### CYLINDER COMPRESSION:

###### #1 CYLINDER

0.63 – 0.83 MPa (6.42 – 8.46 kgf/cm<sup>2</sup>, 91 – 120 psi)

500 rpm

###### #2 CYLINDER

0.32 – 0.52 MPa (3.26 – 5.30 kgf/cm<sup>2</sup>, 46 – 75 psi)

500 rpm

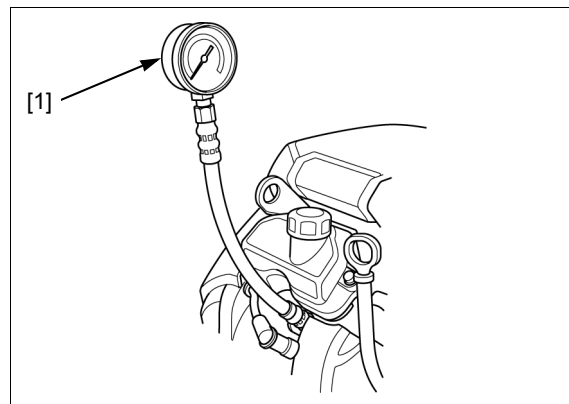

### CYLINDER SLEEVE I.D.

Measure and record the cylinder I.D. at three levels in both the "X" axis (perpendicular to crankshaft) and the "Y" axis (parallel to crankshaft). Take the maximum reading to determine cylinder wear.

#### GX700IRH:

**STANDARD:** 78.000 – 78.015 mm  
(3.0709 – 3.0715 in)

**SERVICE LIMIT:** 78.150 mm (3.0768 in)

#### GX800IRH:

**STANDARD:** 83.000 – 83.015 mm  
(3.2677 – 3.2683 in)

**SERVICE LIMIT:** 83.093 mm (3.2714 in)

If the measurement is more than the service limit, replace the cylinder (page 13-5).

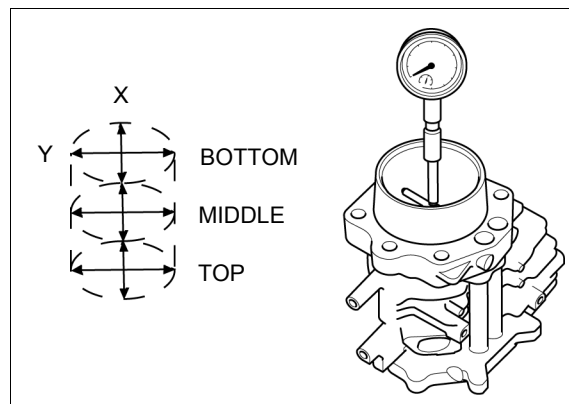

**VALVE SEAT WIDTH**

Remove any carbon deposits from the combustion chamber (page 3-10).

Inspect each valve face for irregularities.

If necessary, replace the valve (page 13-5).

Apply a light coat of Prussian Blue or erasable felt-tipped marker ink to each valve seat.

Using a valve lapper [1], insert the valve, and snap it closed against its seat several times. Be sure the valve does not rotate on the seat. The transferred marking compound will show any area of the valve face that is not concentric.

Measure the valve seat width of the cylinder.

**STANDARD:** 1.0 – 1.2 mm (0.04 – 0.05 in)

**SERVICE LIMIT:** 2.1 mm (0.08 in)

If the measurement is more than the service limit, recondition the valve seat (page 13-14).

Check whether the valve seat contact area of the valve is too high.

If the valve seat is too high, recondition the valve seat (page 13-14).

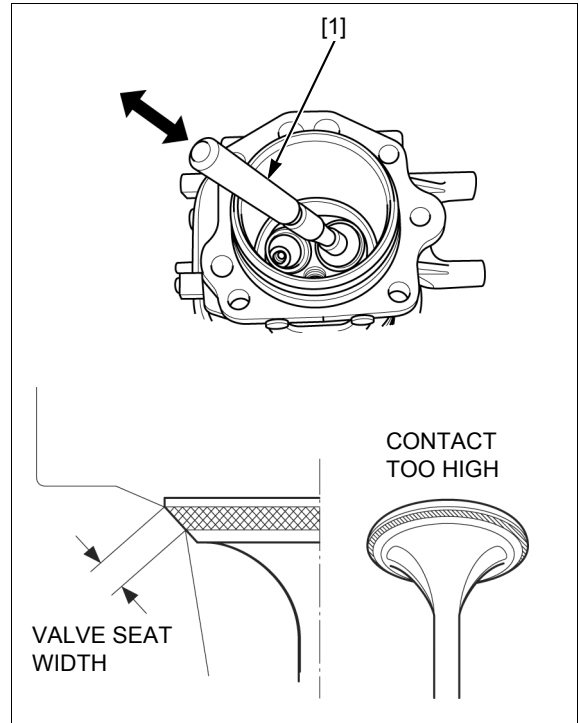

**VALVE GUIDE I.D.**

Ream the valve guide [1] to remove any carbon deposits before measuring.

**TOOL:**

**Valve guide reamer 5.510 mm [2] 07984-200000D**

**NOTICE**

Turn the special tool (Valve guide reamer) clockwise, never counterclockwise.

Continue to rotate the special tool while removing it from the valve guide.

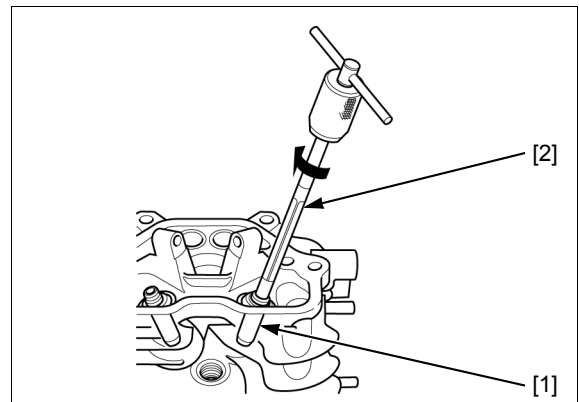

Measure and record each valve guide I.D.

**STANDARD:** 5.500 – 5.512 mm  
(0.2165 – 0.2170 in)

**SERVICE LIMIT:** 5.560 mm (0.2189 in)

If the measured valve guide I.D. is more than the service limit, replace the cylinder (page 13-5).

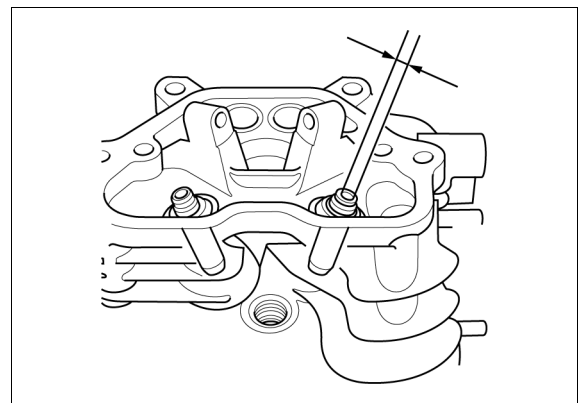

**VALVE STEM O.D.**

Inspect each valve for bending or abnormal stem wear.

If necessary, replace the valve ([page 13-5](#)).

Measure and record each valve stem O.D.

**STANDARD:**

**IN:** 5.475 – 5.490 mm (0.2156 – 0.2161 in)

**EX:** 5.435 – 5.450 mm (0.2140 – 0.2146 in)

**SERVICE LIMIT:**

**IN:** 5.400 mm (0.2126 in)

**EX:** 5.300 mm (0.2087 in)

If the measurement is less than the service limit, replace the valve ([page 13-5](#)).

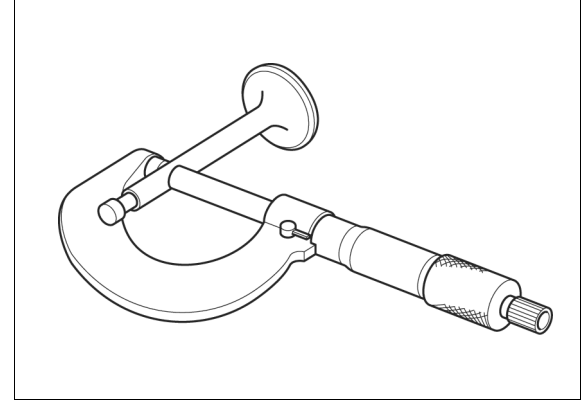
**GUIDE-TO-STEM CLEARANCE**

Subtract each valve stem O.D. from the corresponding valve guide I.D. to obtain the stem-to-guide clearance.

**STANDARD:**

**IN:** 0.010 – 0.037 mm (0.0004 – 0.0015 in)

**EX:** 0.050 – 0.077 mm (0.0020 – 0.0030 in)

**SERVICE LIMIT:**

**IN:** 0.110 mm (0.0043 in)

**EX:** 0.130 mm (0.0051 in)

If the calculated clearance is more than the service limit, replace the following:

- Valve ([page 13-5](#))
- Cylinder ([page 13-5](#))

**VALVE SPRING FREE LENGTH**

Measure the valve spring free length.

**STANDARD:** 38.3 mm (1.51 in)

**SERVICE LIMIT:** 36.8 mm (1.45 in)

If the measured length is less than the service limit, replace the valve spring ([page 13-5](#)).

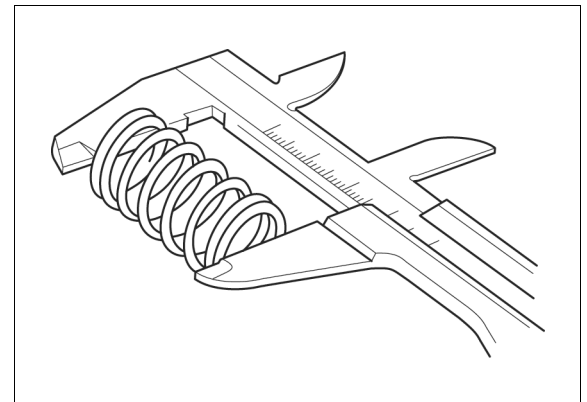
**VALVE SPRING PERPENDICULARITY**

Measure the valve spring perpendicularity.

**STANDARD:** 2° max.

If the measured perpendicularity is more than the specification, replace the valve spring ([page 13-5](#)).

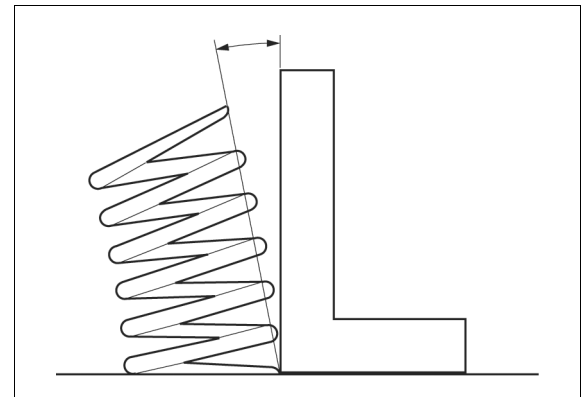

## PUSH ROD RUNOUT

Check both ends of the push rod for wear.

Check the push rod for straightness.

If necessary, replace the push rod ([page 13-2](#)).

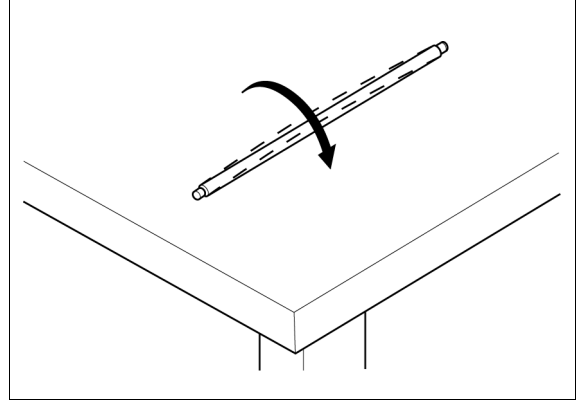

## ROCKER ARM I.D.

Measure the rocker arm I.D.

**STANDARD:** 6.000 – 6.018 mm  
(0.2362 – 0.2369 in)

**SERVICE LIMIT:** 6.043 mm (0.2379 in)

If the measurement is more than the service limit, replace the rocker arm ([page 13-2](#)).

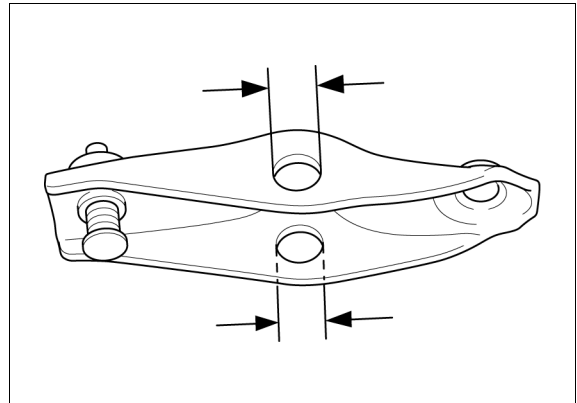

## ROCKER ARM SHAFT O.D.

Measure the rocker arm shaft O.D.

**STANDARD:** 5.960 – 5.990 mm  
(0.2346 – 0.2358 in)

**SERVICE LIMIT:** 5.953 mm (0.2344 in)

If the measurement is less than the service limit, replace the rocker arm shaft ([page 13-2](#)).

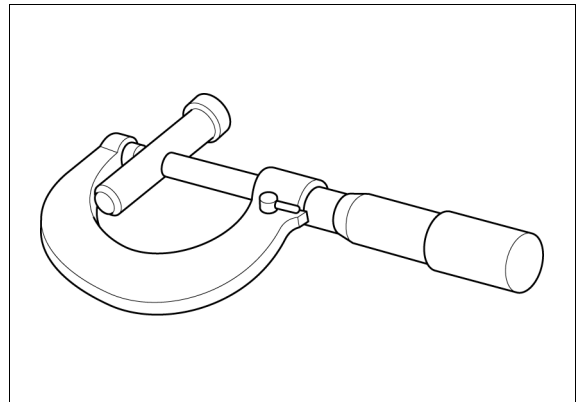

## ROCKER ARM SHAFT BEARING I.D.

Measure the rocker arm shaft bearing I.D.

**STANDARD:** 6.000 – 6.018 mm  
(0.2362 – 0.2369 in)

**SERVICE LIMIT:** 6.043 mm (0.2379 in)

If the measurement is more than the service limit, replace the cylinder ([page 13-5](#)).

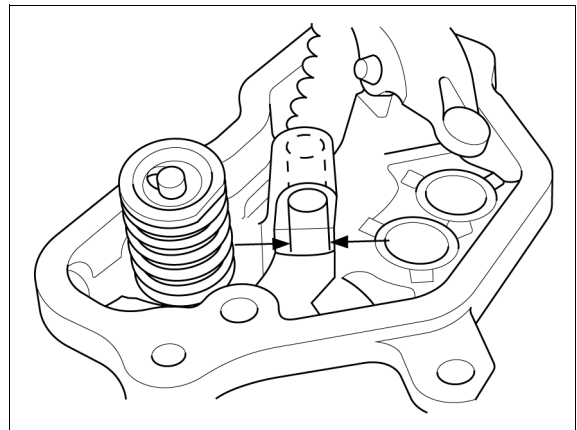

**PISTON SKIRT O.D.**

Measure and record the piston O.D. at a point 10 mm (0.4 in) from the bottom of the skirt and 90 degrees to the piston pin bore.

**GX700IRH:**  
**STANDARD:** 77.975 – 77.985 mm  
 (3.0699 – 3.0703 in)  
**SERVICE LIMIT:** 77.875 mm (3.0659 in)

**GX800IRH:**  
**STANDARD:** 82.975 – 82.985 mm  
 (3.2667 – 3.2671 in)  
**SERVICE LIMIT:** 82.880 mm (3.2630 in)

If the measurement is less than the service limit, replace the piston ([page 13-6](#)).

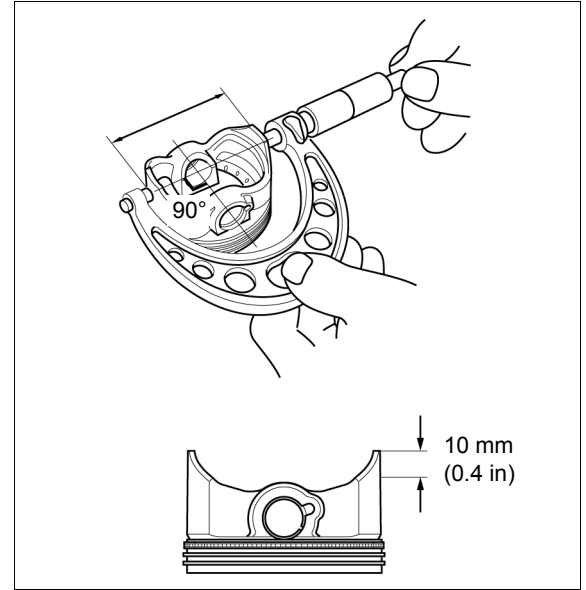

**PISTON-TO-CYLINDER CLEARANCE**

Subtract the piston skirt O.D. from the cylinder sleeve I.D. to obtain the piston-to-cylinder clearance.

**STANDARD:** 0.015 – 0.040 mm  
 (0.0006 – 0.0016 in)  
**SERVICE LIMIT:** 0.12 mm (0.005 in)

If the calculated clearance is more than the service limit, replace the piston ([page 13-6](#)) and recheck the clearance.

If the clearance is still more than the service limit with the new piston, replace the cylinder ([page 13-5](#)).

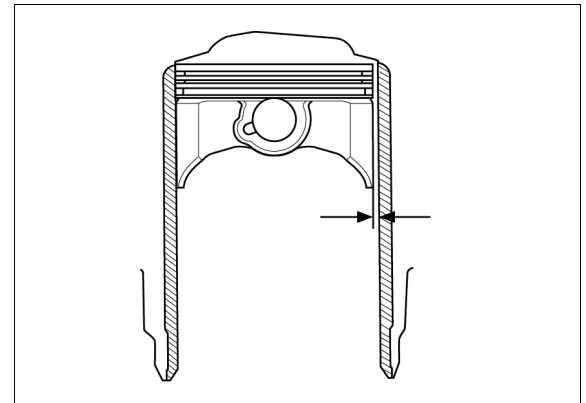

**PISTON PIN BORE I.D.**

Measure and record the piston pin bore I.D. of the piston.

**STANDARD:** 18.002 – 18.008 mm  
 (0.7087 – 0.7090 in)  
**SERVICE LIMIT:** 18.042 mm (0.7103 in)

If the measurement is more than the service limit, replace the piston ([page 13-6](#)).

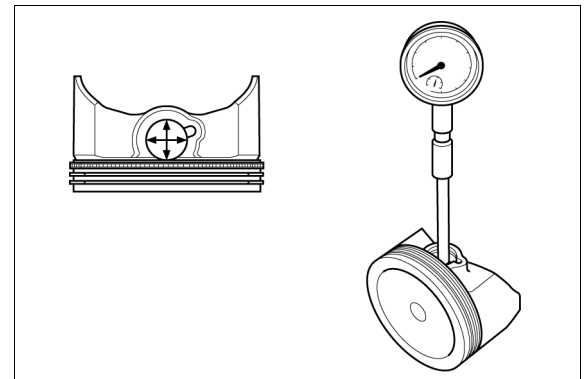

## PISTON PIN O.D.

Measure and record the piston pin O.D. at three points (both ends and middle). Take the minimum reading to determine piston pin O.D.

**STANDARD:** 17.994 – 18.000 mm  
(0.7084 – 0.7087 in)

**SERVICE LIMIT:** 17.95 mm (0.707 in)

If the measurement is less than the service limit, replace the piston pin ([page 13-2](#)).

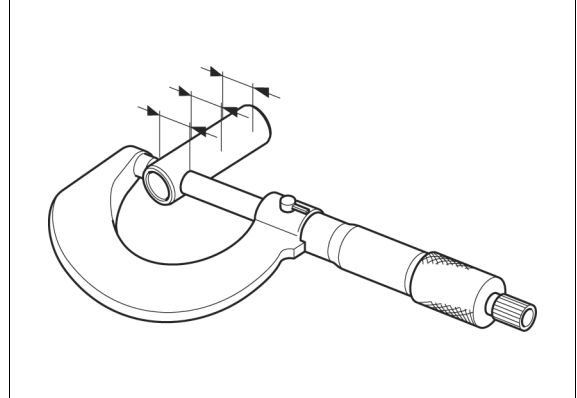

## PISTON PIN-TO-PISTON PIN BORE CLEARANCE

Subtract the piston pin O.D. from the piston pin bore I.D. to obtain the piston pin-to-piston pin bore clearance.

**STANDARD:** 0.002 – 0.014 mm  
(0.0001 – 0.0006 in)

**SERVICE LIMIT:** 0.08 mm (0.003 in)

If the calculated clearance is more than the service limit, replace the piston pin ([page 13-2](#)) and recheck the clearance.

If the clearance is still more than the service limit with the new piston pin, replace the piston ([page 13-6](#)).

## PISTON RING SIDE CLEARANCE

Measure the clearance between each piston ring and ring groove of the piston using feeler gauge.

**STANDARD:**

**Top:** 0.050 – 0.080 mm (0.0020 – 0.0031 in)

**Second:** 0.050 – 0.080 mm (0.0020 – 0.0031 in)

**SERVICE LIMIT:**

**Top:** 0.15 mm (0.06 in)

**Second:** 0.15 mm (0.06 in)

If any of the measurements is more than the service limit, inspect the piston ring width. If necessary replace the piston rings (top, second, oil) as a set ([page 13-6](#)) and reinspect the clearance.

If any of the measurements is still more than the service limit with the new piston rings, replace the piston ([page 13-6](#)).

If the piston ring width is normal, replace the piston ([page 13-6](#)) and reinspect the clearance.

If necessary replace the piston rings (top, second, oil) as a set ([page 13-6](#)) and reinspect the clearance.

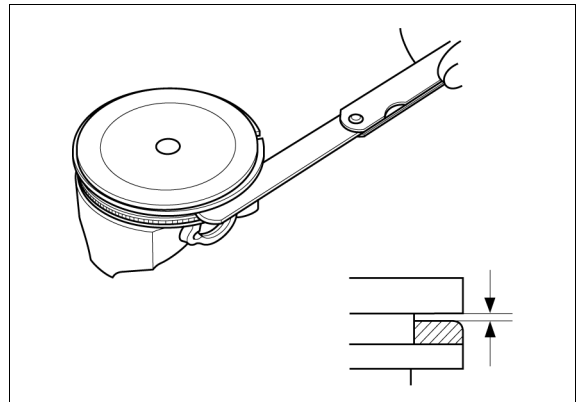

### PISTON RING WIDTH

Measure each piston ring width.

**STANDARD:**

**Top:** 1.140 – 1.155 mm (0.0449 – 0.0455 in)

**Second:** 1.140 – 1.155 mm (0.0449 – 0.0455 in)

**SERVICE LIMIT:**

**Top:** 1.120 mm (0.0441 in)

**Second:** 1.120 mm (0.0441 in)

If any of the measurements is less than the service limit, replace the piston rings (top, second, oil) as a set ([page 13-6](#)).

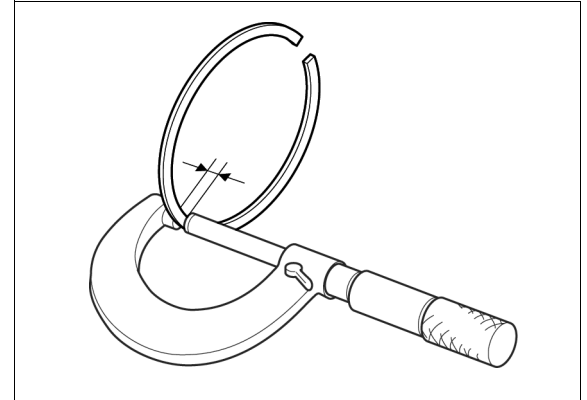

### PISTON RING END GAP

Before inspection, check whether the cylinder sleeve I.D. is within the specification.

Set the piston ring into the cylinder sleeve using the piston head.

Measure each piston ring end gap using a feeler gauge.

**GX700IRH:**

**STANDARD:**

**Top:** 0.200 – 0.350 mm (0.0079 – 0.0138 in)

**Second:** 0.350 – 0.500 mm (0.0138 – 0.0197 in)

**Oil (side rail):** 0.20 – 0.70 mm (0.008 – 0.028 in)

**SERVICE LIMIT:**

**Top:** 0.450 mm (0.0177 in)

**Second:** 0.600 mm (0.0236 in)

**Oil (side rail):** 0.90 mm (0.035 in)

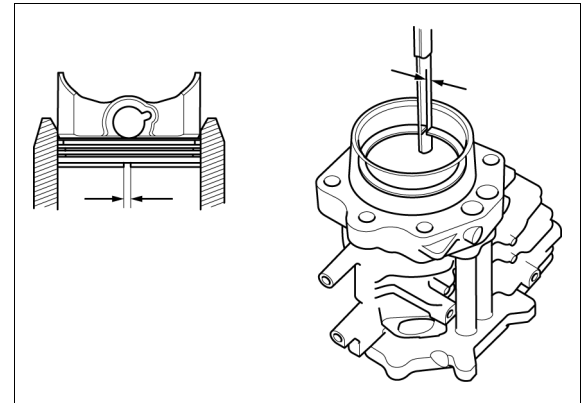

**GX800IRH:**

**STANDARD:**

**Top:** 0.200 – 0.300 mm (0.0079 – 0.0118 in)

**Second:** 0.300 – 0.400 mm (0.0118 – 0.0157 in)

**Oil (side rail):** 0.20 – 0.50 mm (0.0080 – 0.0197 in)

**SERVICE LIMIT:**

**Top:** 0.400 mm (0.0157 in)

**Second:** 0.500 mm (0.0197 in)

**Oil (side rail):** 0.70 mm (0.0276 in)

If any of the measurements is more than the service limit, replace the piston rings (top, second, oil) as a set ([page 13-6](#)).

### CONNECTING ROD SMALL END I.D.

Measure the connecting rod small end I.D.

**STANDARD:** 18.006 – 18.018 mm  
(0.7089 – 0.7094 in)

**SERVICE LIMIT:** 18.07 mm (0.711 in)

If the measurement is more than the service limit, replace the connecting rod ([page 14-4](#)).

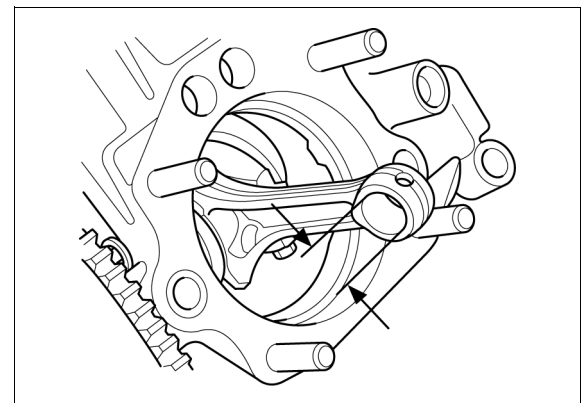



## VALVE SEAT RECONDITIONING

Commercially available valve seat cutters/grinders or equivalent valve seat refacing equipment are recommended to correct worn valve seats.

Using a 45° cutter remove enough material to produce a smooth and concentric seat.

**TOOLS (commercially available):**

**Cutter holder 5.5 mm [1]**

**Seat cutter 33 mm (45° IN) [2]**

**Seat cutter 27.5 mm (45° EX) [2]**

Turn the cutter clockwise, never counterclockwise. Continue to turn the cutter as you lift it from the valve seat.

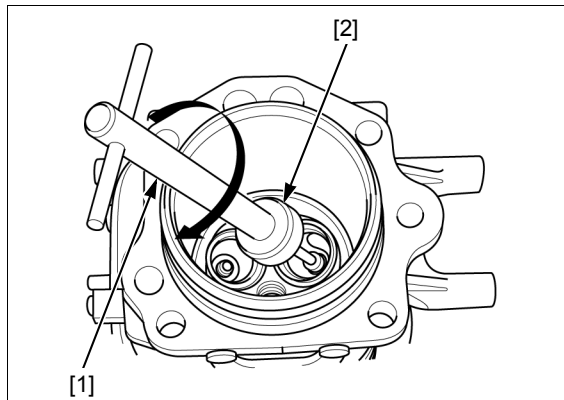

Use the 32° and 60° cutters to adjust the valve seat so that it contacts the middle of the valve face.

The 32° cutter removes material from the top edge.

**GX700IRH:**

**TOOLS (commercially available):**

**Cutter holder 5.5 mm**

**Flat cutter 33 mm (32° IN)**

**Flat cutter 30 mm (32° EX)**

**GX800IRH:**

**TOOLS (commercially available):**

**Cutter holder 5.5 mm**

**Flat cutter 35 mm (32° IN)**

**Flat cutter 30 mm (32° EX)**

The 60° cutter removes material from the bottom edge.

**GX700IRH:**

**TOOLS (commercially available):**

**Cutter holder 5.5 mm**

**Interior cutter 30 mm (60° IN)**

**Interior cutter 26 mm (60° EX)**

**GX800IRH:**

**TOOLS (commercially available):**

**Cutter holder 5.5 mm**

**Interior cutter 34 mm (60° IN)**

**Interior cutter 26 mm (60° EX)**

Be sure that the width of the finished valve seat is within specification.

Make a light pass with 45° cutter to remove any possible burrs at the edge of the seat.

**TOOLS (commercially available):**

**Cutter holder 5.5 mm**

**Seat cutter 33 mm (45° IN)**

**Seat cutter 27.5 mm (45° EX)**

After resurfacing the seats, inspect for even valve seating.

Apply Prussian Blue compound or erasable felt-tipped marker ink to the valve seat. Insert the valve, and snap it closed against its seat several times. Be sure the valve does not rotate on the seat.

The seating surface, as shown by the transferred marking compound, should have good contact all the way around.

Thoroughly clean the cylinder to remove any cutting residual.

Lap the valves into their seats, using a commercially available valve lapper [1] and lapping compound.

After lapping, wash all residual compound off the cylinder and valve.

**NOTICE**

*To avoid severe engine damage, be sure to remove all lapping compound from the engine before reassembly.*

Adjust the valve clearance after reassembly ([page 3-8](#)).

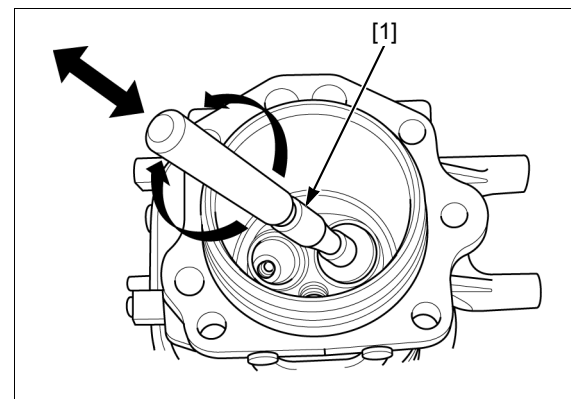
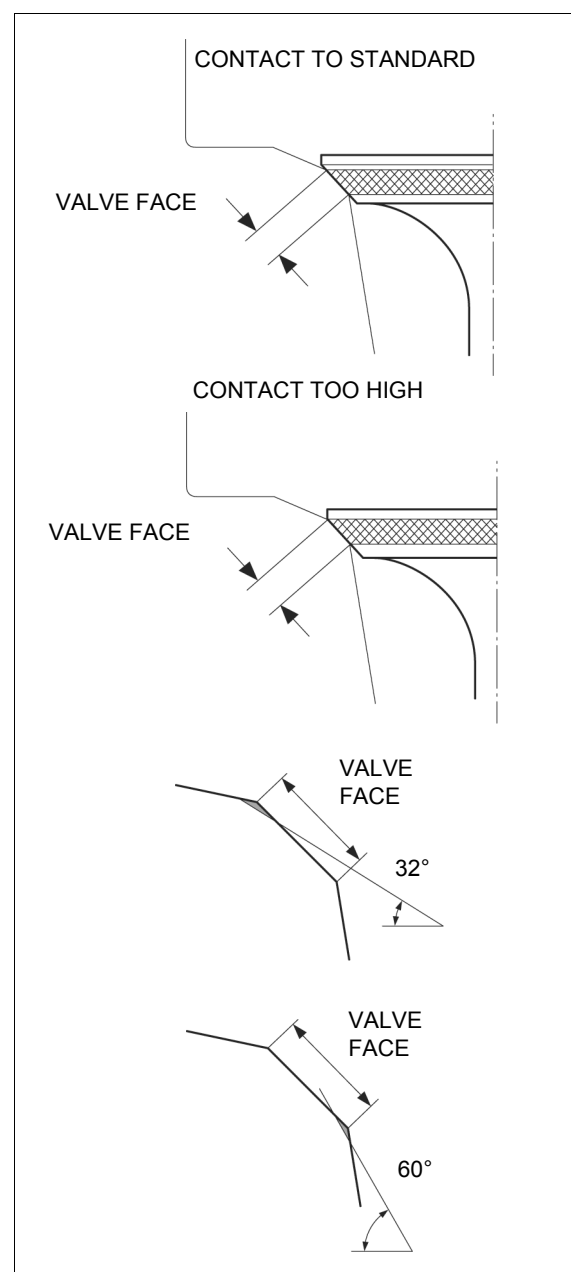

---

**MEMO**

---

CRANKCASE COVER .....	14-2	CRANKCASE COVER/CRANKCASE/ CRANKSHAFT/CONNECTING ROD/ CAMSHAFT/VALVE LIFTER INSPECTION .....	14-8
CRANKSHAFT/CONNECTING ROD/ CAMSHAFT/VALVE LIFTER .....	14-4	CRANKSHAFT OIL SEAL REPLACEMENT (CRANKCASE COVER SIDE) .....	14-14
BREATHER .....	14-5	CRANKSHAFT OIL SEAL REPLACEMENT (CRANKCASE SIDE) .....	14-15
OIL PUMP/OIL FILTER .....	14-7	CRANKCASE STUD BOLT REPLACEMENT .....	14-16
VALVE LIFTER.....	14-8		

# CRANKCASE

## CRANKCASE COVER

### REMOVAL

Drain the engine oil (page 3-4).

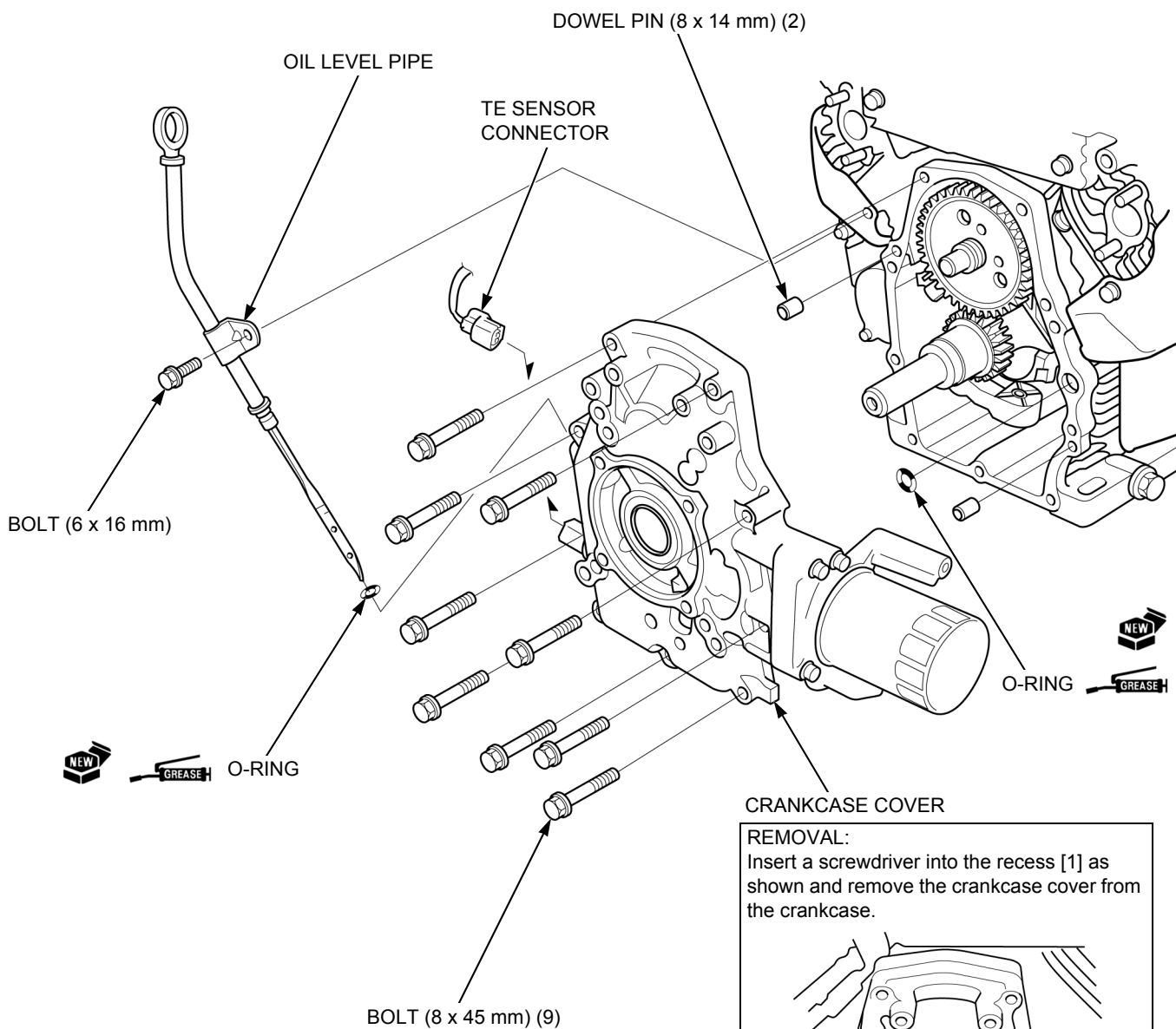

**REMOVAL:**  
Insert a screwdriver into the recess [1] as shown and remove the crankcase cover from the crankcase.

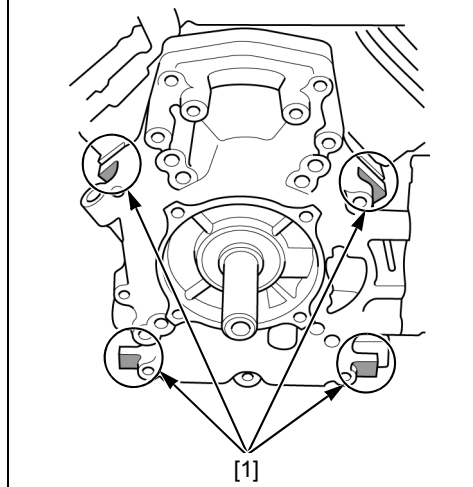

## INSTALLATION

Clean the mating surfaces of the crankcase cover and crankcase of old liquid gasket, oil and other foreign material.

Apply a bead ( $\Phi 1.0 - 1.5$  mm ( $\Phi 0.04 - 0.06$  in)) of liquid gasket (Threebond TB1207B) to the mating surface of the crankcase cover as shown.

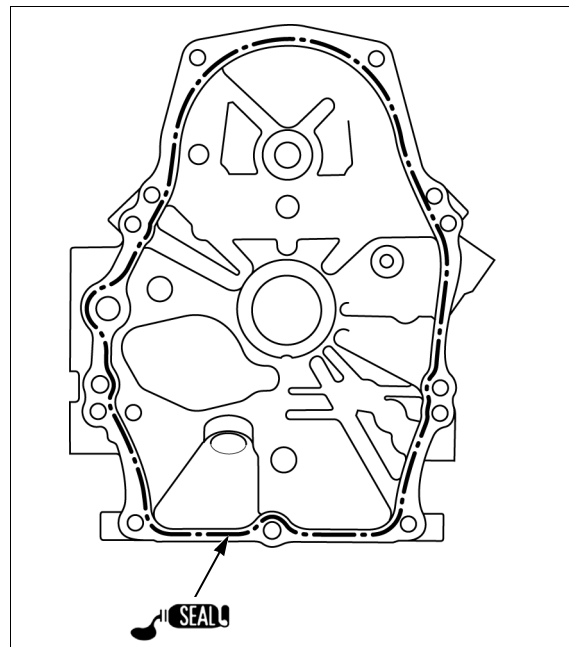

Apply grease to the O-ring [1].

Install the two dowel pins [2] and O-ring to the crankcase.

Apply a light coat of molybdenum oil solution to the main journal part of the crankshaft and crankcase cover [3].

Install the crankcase cover and tighten the nine flange bolts [4] securely.

- Assemble the cylinder within 3 minutes after applying liquid gasket.
- Wait for 30 minutes after assembly before filling with oil and starting the engine.

Connect the TE sensor connector [5].

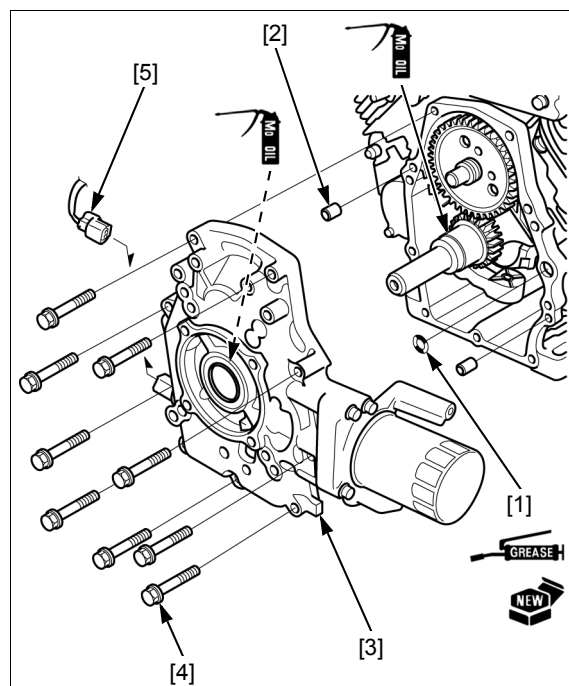

# CRANKCASE

## CRANKSHAFT/CONNECTING ROD/ CAMSHAFT/VALVE LIFTER

### REMOVAL/INSTALLATION

Remove the following:

- Flywheel (page 7-4)
- Cylinders (page 13-2)
- Crankcase cover (page 14-2)

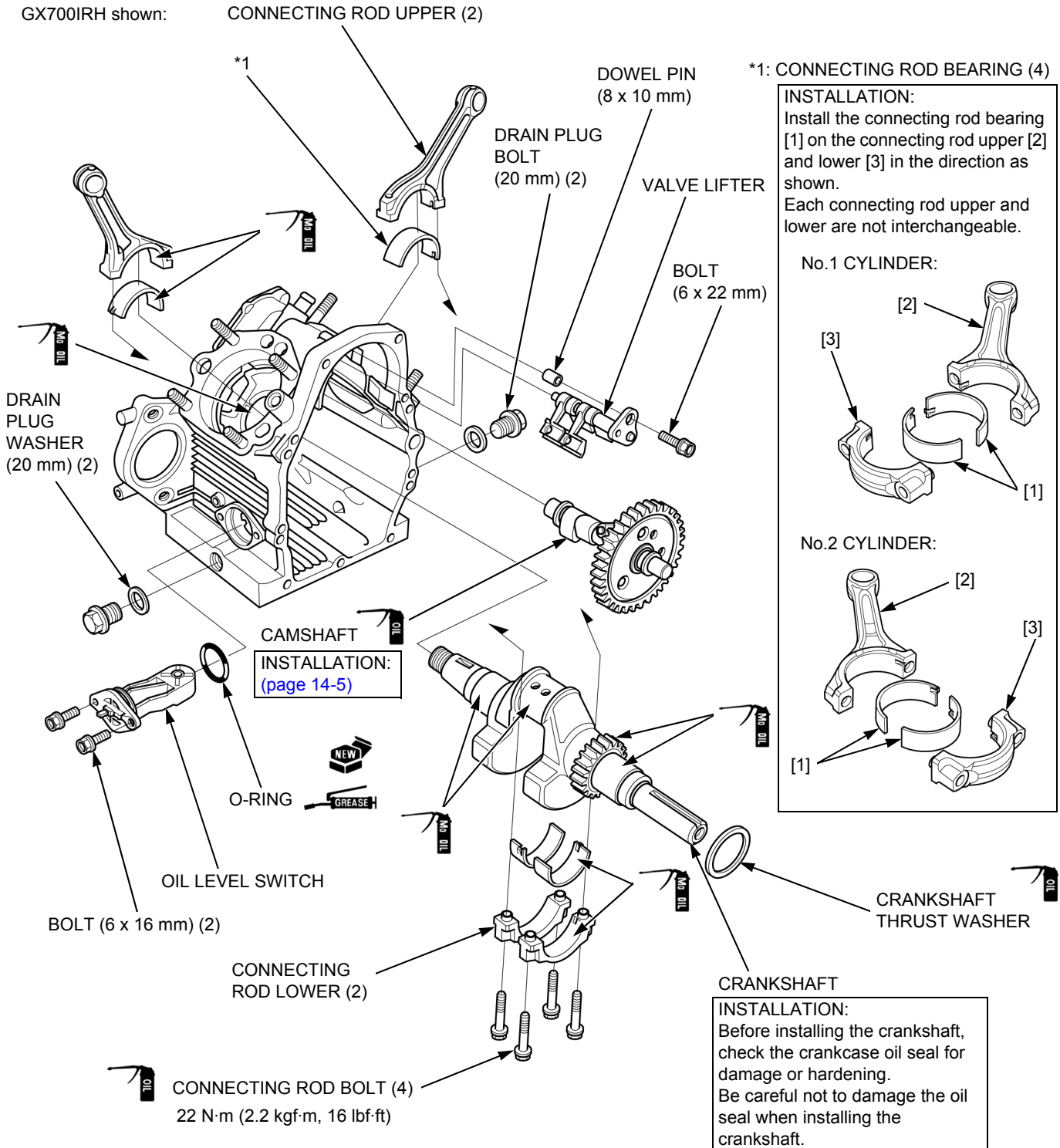

**CAMSHAFT INSTALLATION**

Open the valve lifters in the crankcase.

Install the camshaft [1] to the crankcase [2] by aligning the punch marks [3] on the camshaft and the crankshaft [4] (marked on the timing gear).

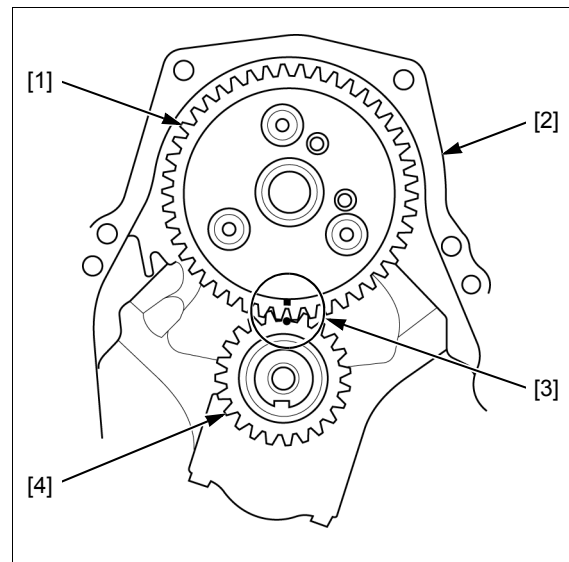

**BREATHER**

**REMOVAL/INSTALLATION**

Remove the charge coil (page 7-7).

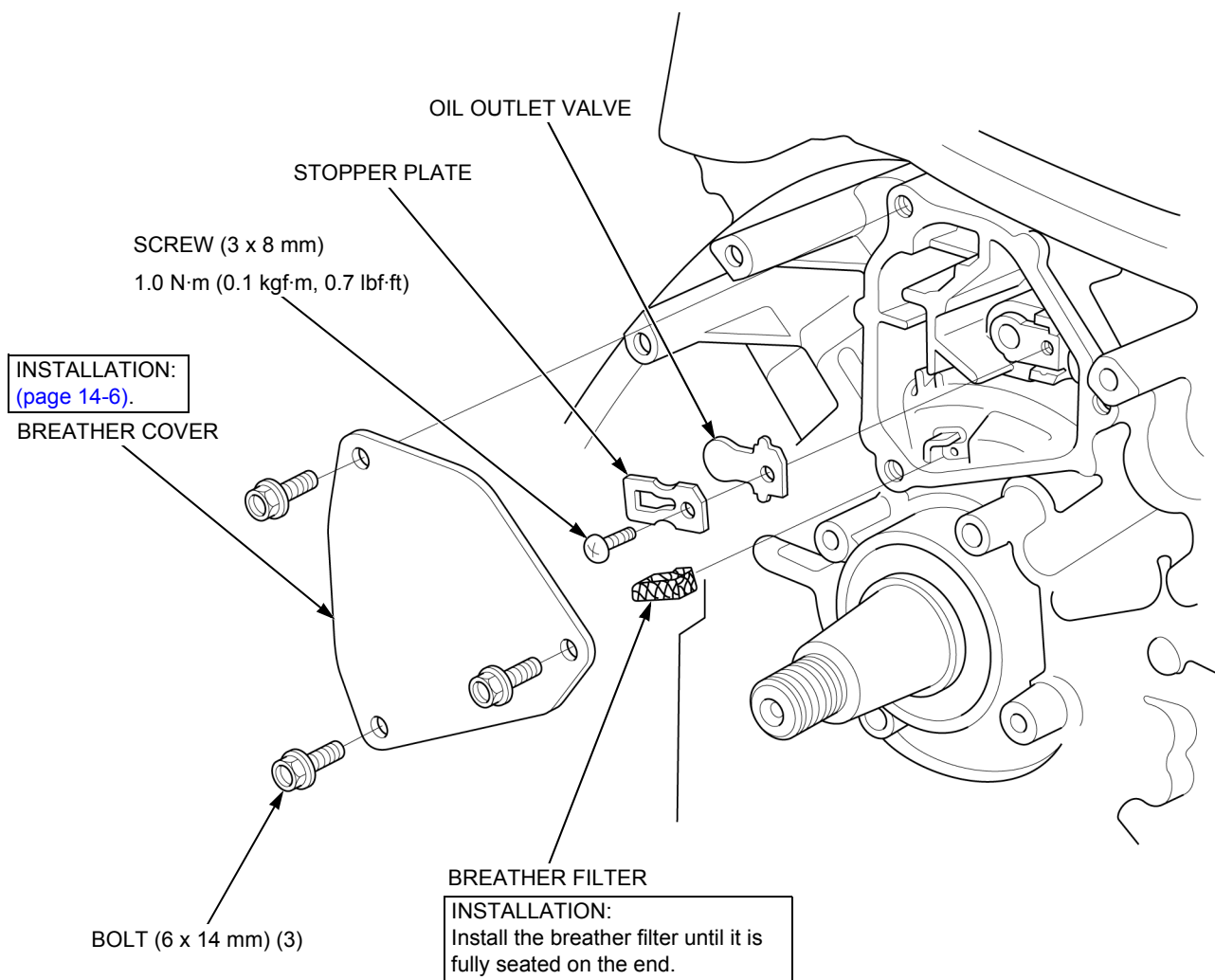



## CRANKCASE

### BREATHER COVER INSTALLATION

Clean the mating surfaces of the breather cover and crankcase of old liquid gasket, oil and other foreign material.

Apply a bead ( $\Phi 1.0 - 1.5$  mm ( $\Phi 0.04 - 0.06$  in)) of liquid gasket (Threebond TB1207B) to the mating surface of the crankcase as shown.

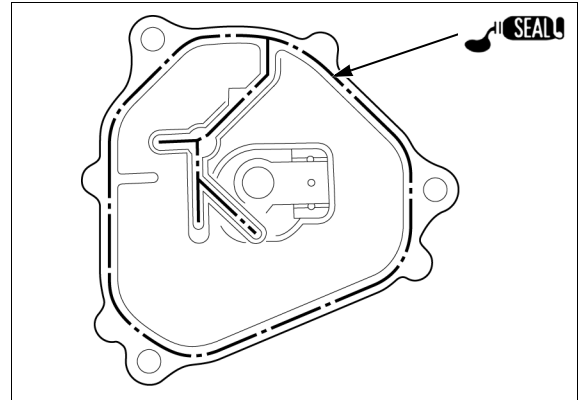

Install the breather cover [1] and tighten the three flange bolts [2] securely.

- Be sure not to catch the breather filter between the breather cover and crankcase.
- Assemble the breather cover within 3 minutes after applying liquid gasket.
- Wait for 30 minutes after assembly before filling with oil and starting the engine.

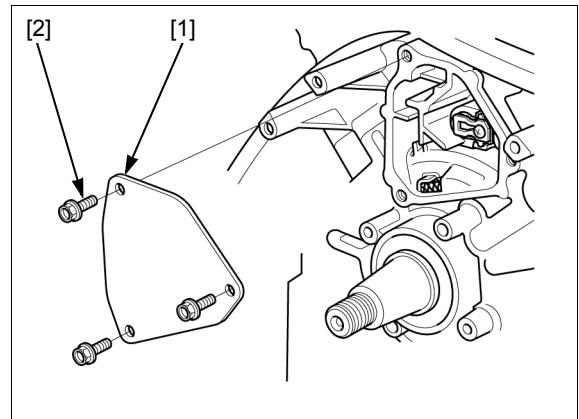

# OIL PUMP/OIL FILTER

## DISASSEMBLY/ASSEMBLY

Remove the crankcase cover (page 14-2).

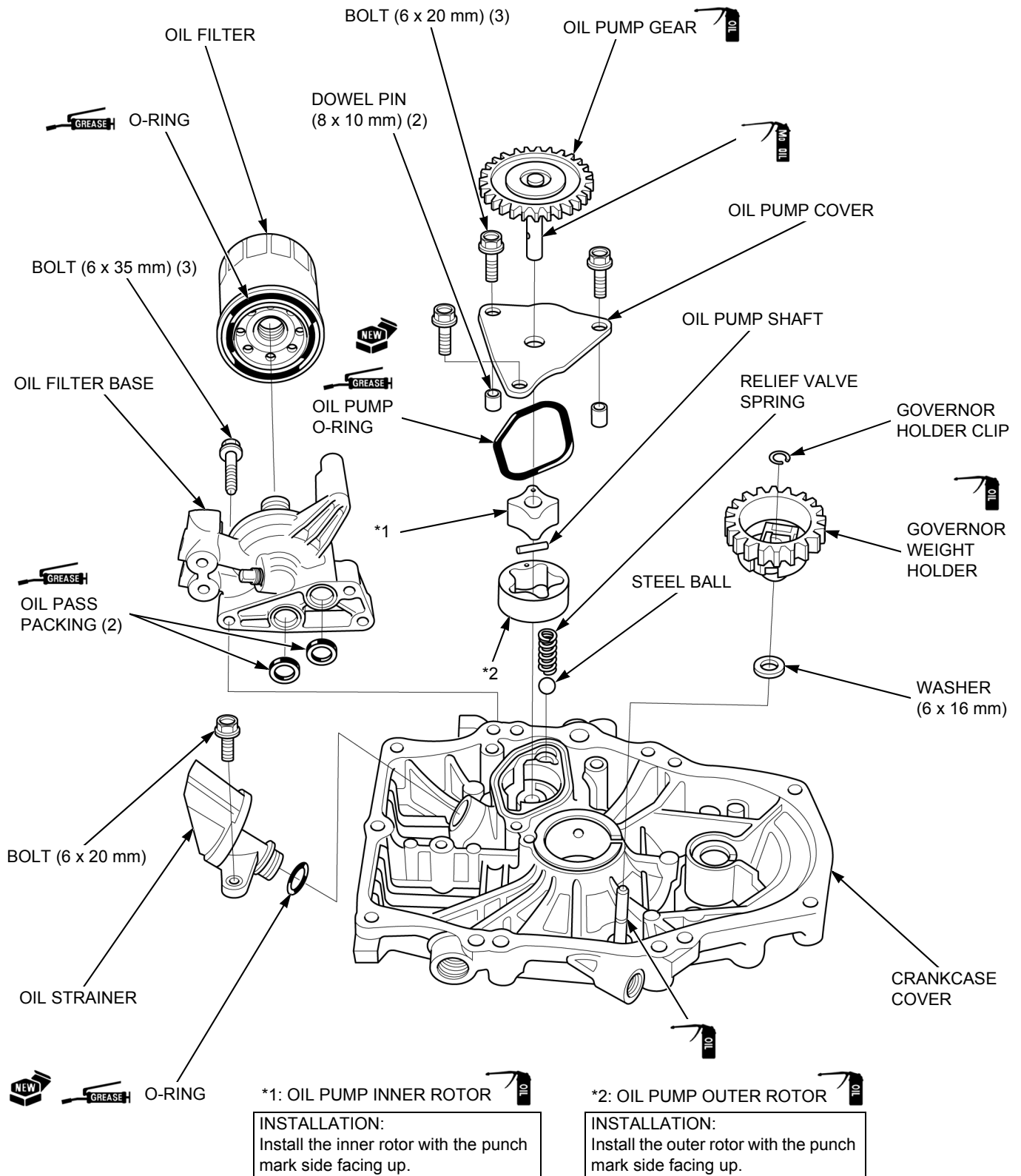

## CRANKCASE

### VALVE LIFTER

#### DISASSEMBLY/ASSEMBLY

Remove the valve lifter (page 14-4).

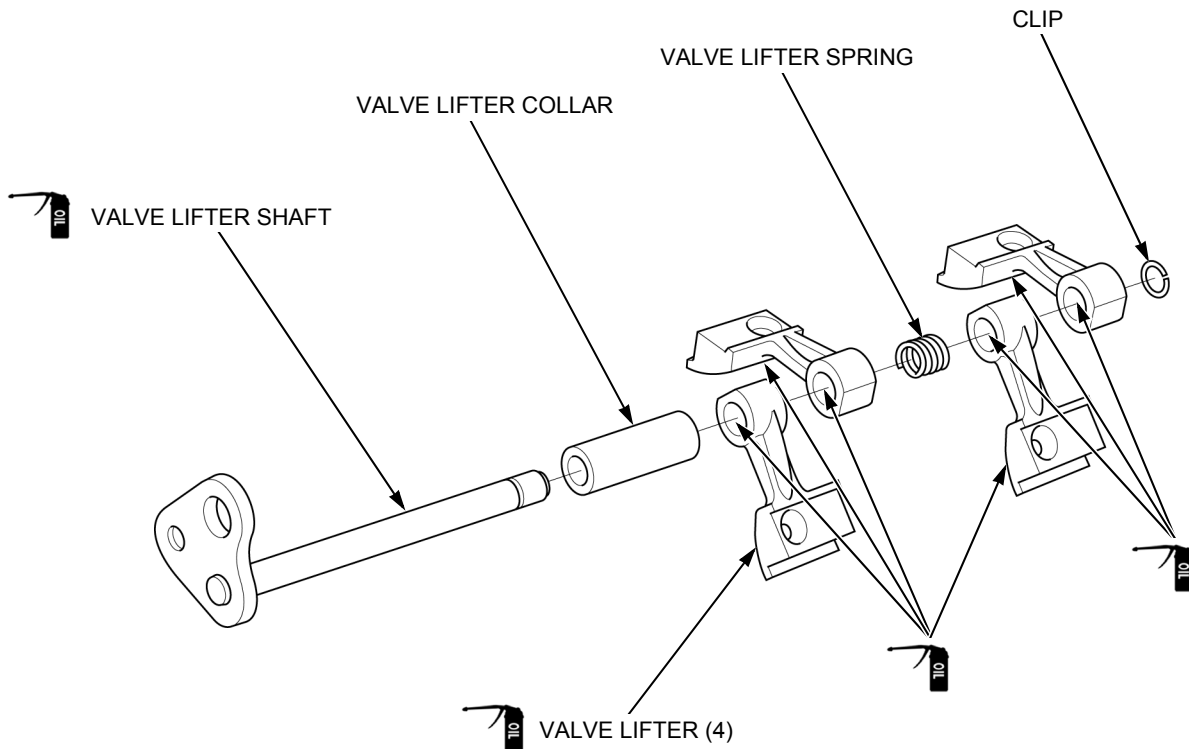

## CRANKCASE COVER/CRANKCASE/ CRANKSHAFT/CONNECTING ROD/ CAMSHAFT/VALVE LIFTER INSPECTION

### CRANKSHAFT AXIAL CLEARANCE

Remove the connecting rods (page 14-4).

Reinstall the crankcase cover.

Measure the crankshaft axial clearance.

**STANDARD:** 0.05 – 0.45 mm (0.002 – 0.018 in)

**SERVICE LIMIT:** 1.0 mm (0.04 in)

If the measurement is more than the service limit, inspect the crankshaft thrust washer (page 14-11).

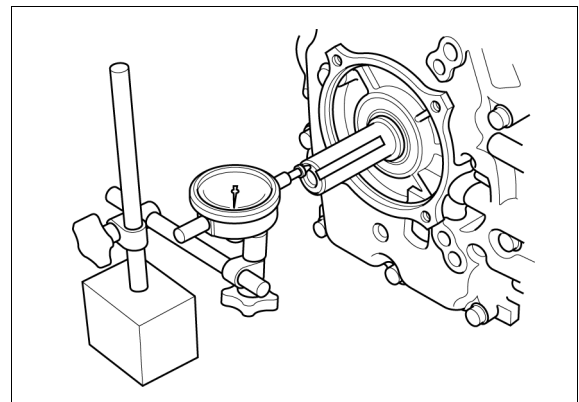

**MAIN JOURNAL I.D.: CRANKCASE COVER SIDE**

Measure the main journal I.D. of the crankcase cover.

**STANDARD:** 40.025 – 40.041 mm  
(1.5758 – 1.5764 in)

**SERVICE LIMIT:** 40.06 mm (1.577 in)

If the measurement is more than the service limit, replace the crankcase cover ([page 14-2](#)).

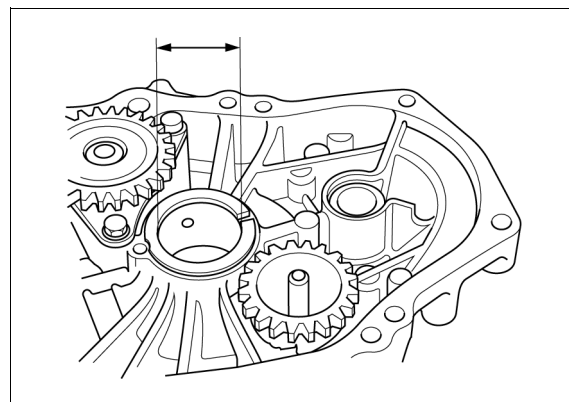

**MAIN JOURNAL I.D.: CRANKCASE SIDE**

Measure the main journal I.D. of the crankcase.

**STANDARD:** 40.025 – 40.041 mm  
(1.5758 – 1.5764 in)

**SERVICE LIMIT:** 40.06 mm (1.577 in)

If the measurement is more than the service limit, replace the crankcase ([page 14-4](#)).

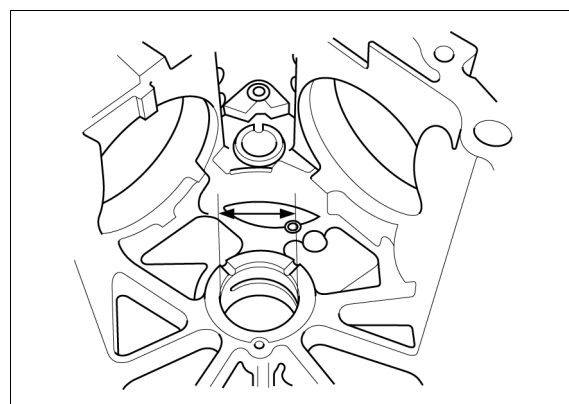

**CAMSHAFT BEARING I.D.: CRANKCASE COVER SIDE**

Measure the camshaft bearing I.D. of the crankcase cover.

**STANDARD:** 17.016 – 17.027 mm  
(0.6699 – 0.6704 in)

**SERVICE LIMIT:** 17.06 mm (0.672 in)

If the measurement is more than the service limit, replace the crankcase cover ([page 14-2](#)).

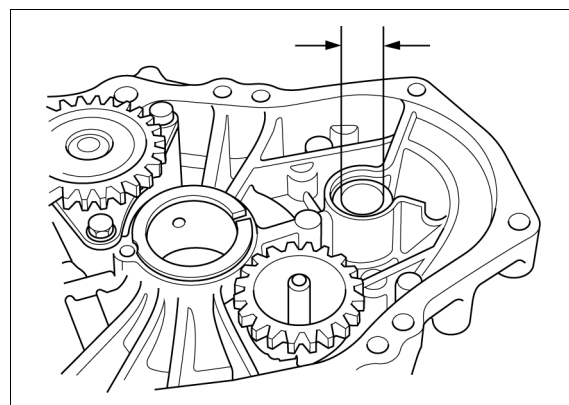

## CRANKCASE

### CAMSHAFT BEARING I.D.: CRANKCASE SIDE

Measure the camshaft bearing I.D. of the crankcase.

**STANDARD:** 17.016 – 17.027 mm  
(0.6699 – 0.6704 in)

**SERVICE LIMIT:** 17.06 mm (0.672 in)

If the measurement is more than the service limit, replace the crankcase ([page 14-4](#)).

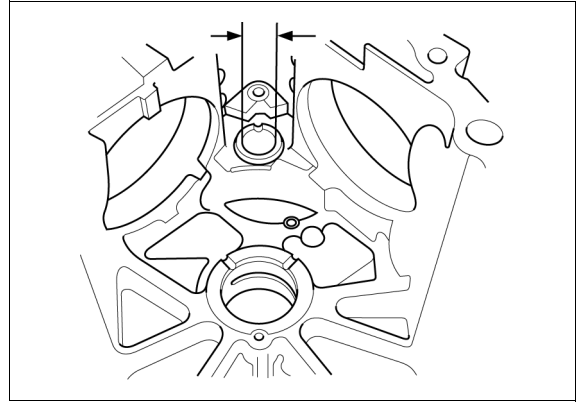

### CRANKPIN O.D.

Measure the crankpin O.D. of the crankshaft.

**STANDARD:** 44.973 – 44.983 mm  
(1.7706 – 1.7710 in)

**SERVICE LIMIT:** 44.920 mm (1.7685 in)

If the measurement is less than the service limit, replace the crankshaft ([page 14-4](#)).

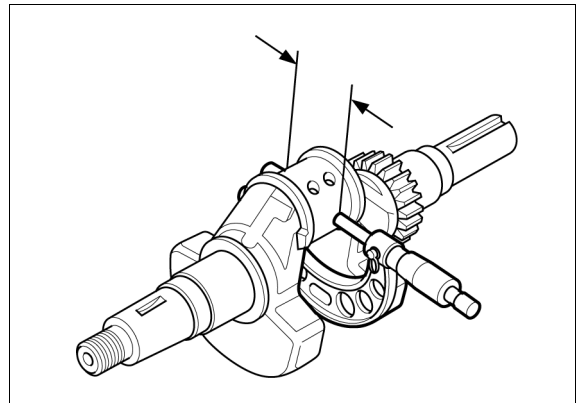

### CRANKSHAFT MAIN JOURNAL O.D.

Measure the main journal O.D. of the crankshaft.

**STANDARD:** 39.984 – 40.000 mm  
(1.5742 – 1.5748 in)

**SERVICE LIMIT:** 39.930 mm (1.5720 in)

If the measurement is less than the service limit, replace the crankshaft ([page 14-4](#)).

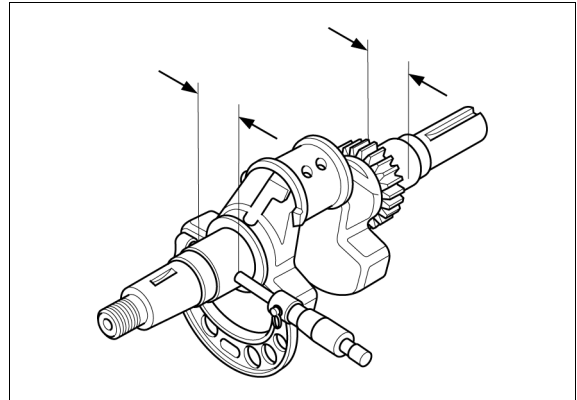

## CRANKSHAFT THRUST WASHER THICKNESS

Measure the crankshaft thrust washer thickness.

**STANDARD:** 0.95 – 1.05 mm  
(0.037 – 0.041 in)  
**SERVICE LIMIT:** 0.80 mm (0.031 in)

If the measurement is less than the service limit, replace the crankshaft thrust washer ([page 14-4](#)).

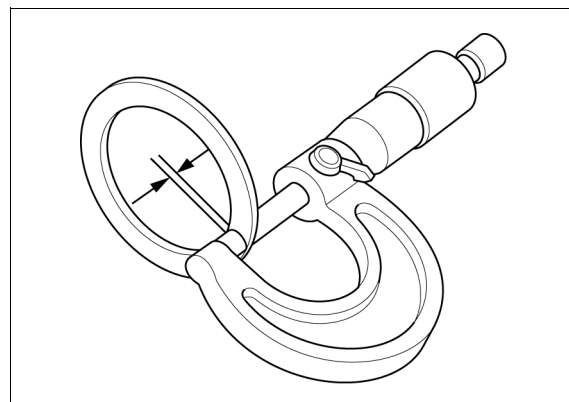

## CONNECTING ROD BIG END SIDE CLEARANCE

Measure the clearance between the connecting rod big end and crankshaft using a feeler gauge.

**STANDARD:** 0.2 – 0.4 mm (0.008 – 0.016 in)  
**SERVICE LIMIT:** 1.000 mm (0.0394 in)

If the measurement is more than the service limit, replace the connecting rod ([page 14-4](#)) and recheck the clearance.

If the clearance is still more than the service limit with the new connecting rod, replace the crankshaft ([page 14-4](#)).

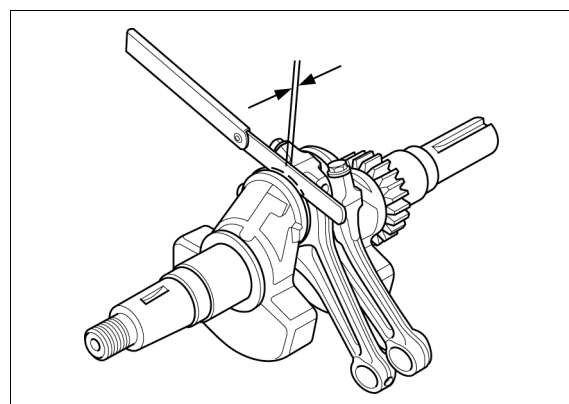

## CONNECTING ROD BIG END I.D.

Set the connecting rod lower and connecting rod bearings to the connecting rod upper and tighten the connecting rod bolts to the specified torque.

**TORQUE:** 22 N·m (2.2 kgf·m, 16 lbf·ft)

Measure the connecting rod big end I.D.

**STANDARD:** 44.988 – 45.012 mm  
(1.7712 – 1.7721 in)  
**SERVICE LIMIT:** 45.050 mm (1.7736 in)

If the measurement is more than the service limit, replace the connecting rod bearings ([page 14-4](#)).

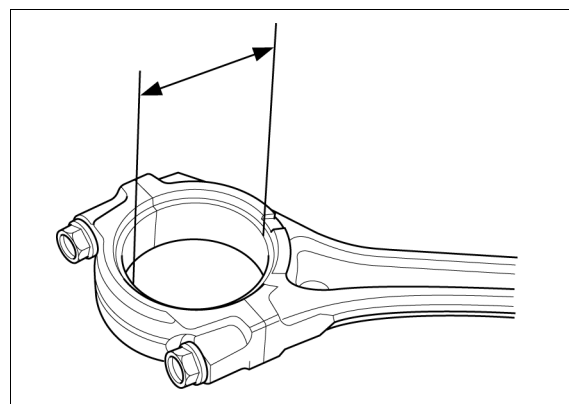

### CONNECTING ROD BIG END OIL CLEARANCE

Clean all oil from the crankpin, connecting rod big end surface and connecting rod bearings.

Place a piece of plastigauge on the crankpin, install the connecting rod upper, the connecting rod lower and the connecting rod bearings, and tighten the connecting rod bolts to the specified torque.

**TORQUE: 22 N·m (2.2 kgf·m, 16 lbf·ft)**

Do not rotate the crankshaft while the plastigauge is in place.

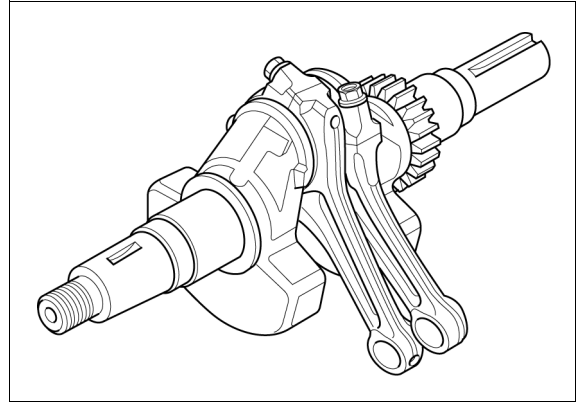

Remove the connecting rod and measure the plastigauge.

**STANDARD:** 0.005 – 0.039 mm  
(0.0002 – 0.0015 in)

**SERVICE LIMIT:** 0.070 mm (0.0028 in)

If the clearance is more than the service limit, replace the connecting rod bearings ([page 14-4](#)) and recheck the clearance.

If the clearance is still more than the service limit with the new connecting rod bearings, replace the crankshaft ([page 14-4](#)).

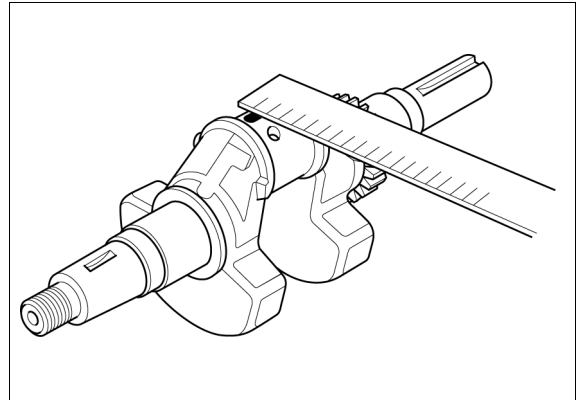

### CAMSHAFT CAM HEIGHT

Measure the cam height of the camshaft.

**GX700IRH:**

**STANDARD:**

**IN:** 29.506 – 29.706 mm (1.1617 – 1.1695 in)

**EX:** 29.410 – 29.610 mm (1.1579 – 1.1657 in)

**SERVICE LIMIT:**

**IN:** 29.36 mm (1.156 in)

**EX:** 29.26 mm (1.152 in)

**GX800IRH:**

**STANDARD:**

**IN:** 29.878 – 30.078 mm (1.1763 – 1.1842 in)

**EX:** 29.598 – 29.798 mm (1.1653 – 1.1731 in)

**SERVICE LIMIT:**

**IN:** 29.848 mm (1.1751 in)

**EX:** 29.568 mm (1.1641 in)

If the measurement is less than the service limit, replace the camshaft ([page 14-4](#)).

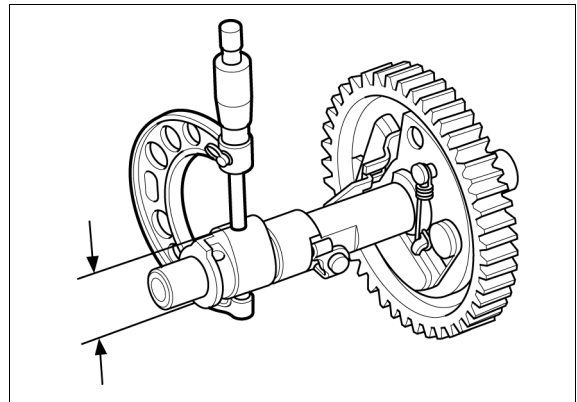

**CAMSHAFT O.D.**

Measure the camshaft O.D. of the camshaft.

**STANDARD:** 16.982 – 17.000 mm  
(0.6686 – 0.6693 in)

**SERVICE LIMIT:** 17.100 mm (0.6732 in)

If the measurement is less than the service limit, replace the camshaft (page 14-4).

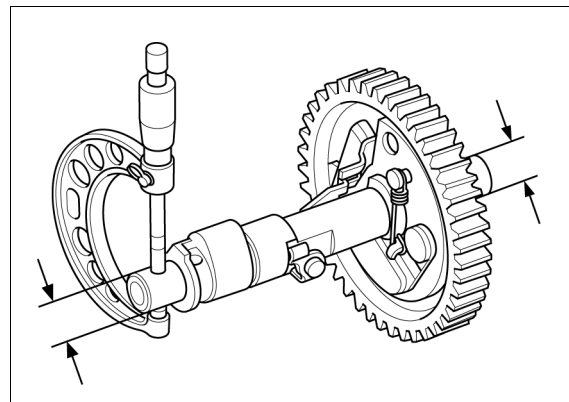

**DECOMPRESSOR WEIGHT**

Check for worn and weakened weight return spring [1].

If the spring is worn or weakened, replace it.

Check that the decompressor weight [2] moves smoothly.

If the decompressor weight does not move correctly, replace the camshaft (page 14-4).

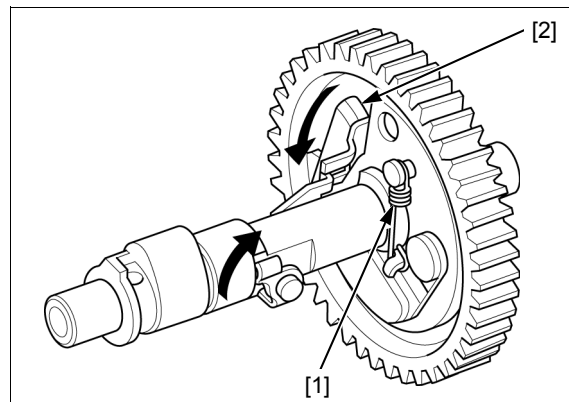

**VALVE LIFTER I.D.**

Measure the valve lifter I.D.

**STANDARD:** 6.010 – 6.040 mm  
(0.2366 – 0.2378 in)

**SERVICE LIMIT:** 6.070 mm (0.2390 in)

If the measurement is more than the service limit, replace the valve lifter (page 14-8).

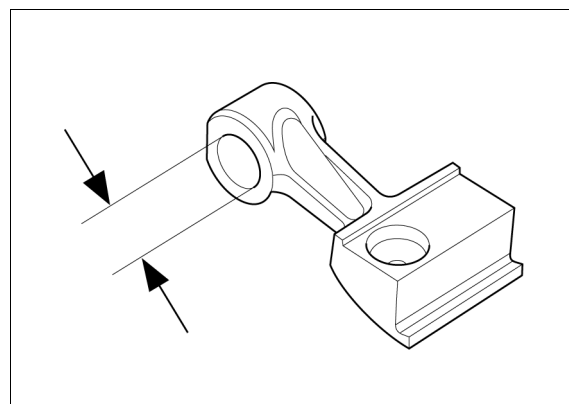

**VALVE LIFTER SHAFT O.D.**

Measure the valve lifter shaft O.D.

**STANDARD:** 5.970 – 6.000 mm  
(0.2350 – 0.2362 in)

**SERVICE LIMIT:** 5.940 mm (0.2339 in)

If the measurement is less than the service limit, replace the valve lifter shaft (page 14-8).

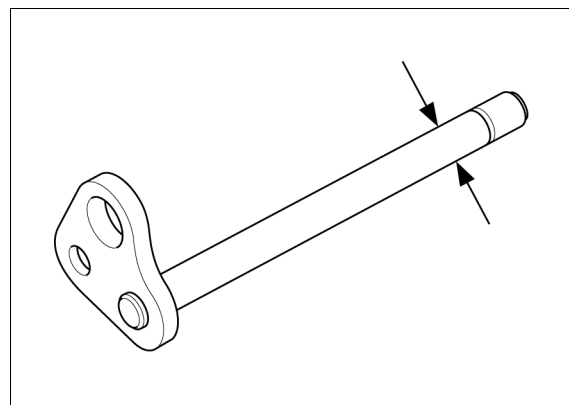



## CRANKCASE

# CRANKSHAFT OIL SEAL REPLACEMENT (CRANKCASE COVER SIDE)

### LOCATION

CRANKSHAFT OIL SEAL  
(38 x 58 x 9 mm)

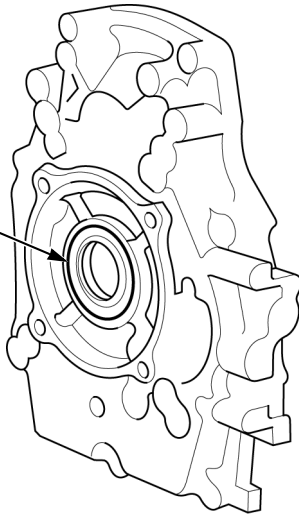

### CRANKSHAFT OIL SEAL (38 x 58 x 9 mm)

Remove the crankcase cover (page 14-2).

Remove the oil seal [1] from the crankcase cover [2].

Apply engine oil to the outer surface of a new oil seal.

Drive the new oil seal in the position as shown using the special tools.

#### TOOLS:

Driver [3]

07749-0010000

Oil seal driver attachment

60 mm [4]

07GAD-PG40100

Apply grease to the lip of the oil seal.

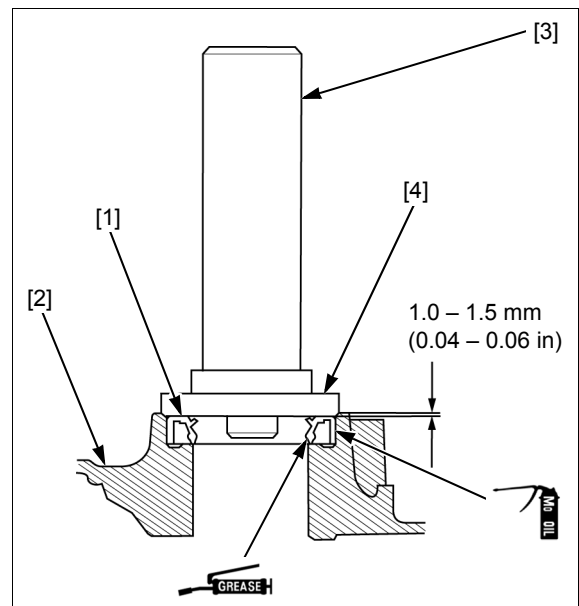

# CRANKSHAFT OIL SEAL REPLACEMENT (CRANKCASE SIDE)

## LOCATION

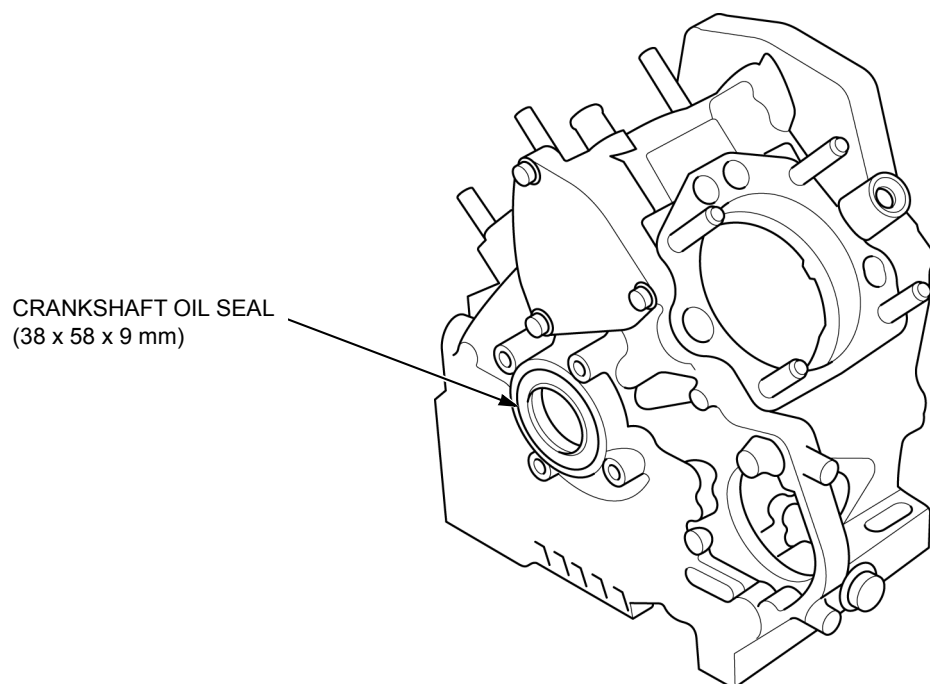

## CRANKSHAFT OIL SEAL (38 x 58 x 9 mm)

Remove the crankshaft ([page 14-4](#)).

Remove the oil seal [1] from the crankcase [2].

Apply oil to the outer surface of a new oil seal.

Drive the new oil seal in the position as shown using the special tools.

### TOOLS:

Driver [3] 07749-0010000

Oil seal driver attachment

60 mm [4] 07GAD-PG40100

Apply grease to the lip of the oil seal.

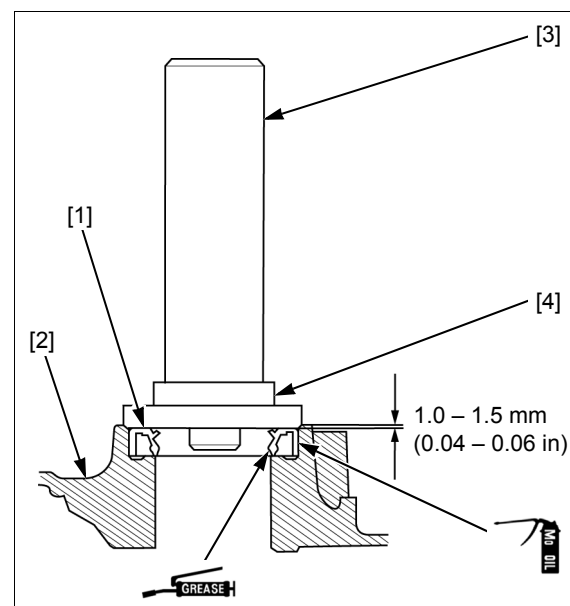

## CRANKCASE

# CRANKCASE STUD BOLT REPLACEMENT

Thread two nuts onto the stud bolt and tighten them together, then use a wrench to turn the stud bolt out.

Screw the stud bolt to its incomplete thread [1].

**SPECIFIED LENGTH:**

Upper side [2]: 40 mm (1.6 in)

Lower side [3]: 30 mm (1.2 in)

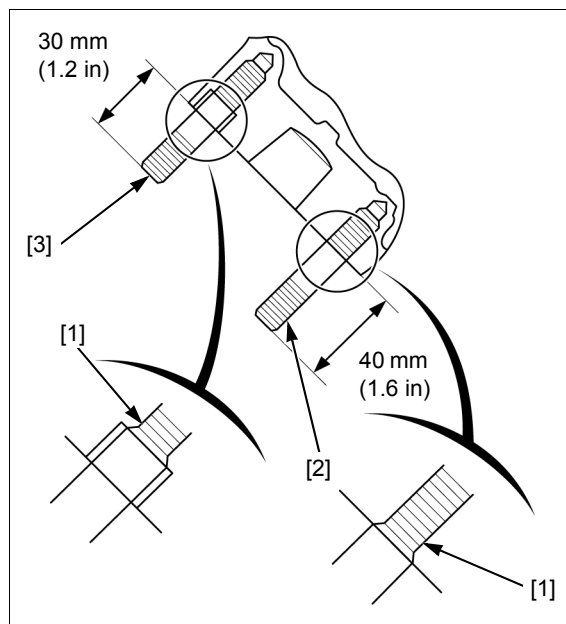

# 15. TECHNICAL FEATURES

---

FUEL INJECTION SYSTEM.....15-2

CAULKING CLAMP ..... 15-3

## TECHNICAL FEATURES

# FUEL INJECTION SYSTEM

### COMPONENT LOCATION

This model is equipped with the fuel injection system instead of a conventional carburetor.

The system consists of the following components:

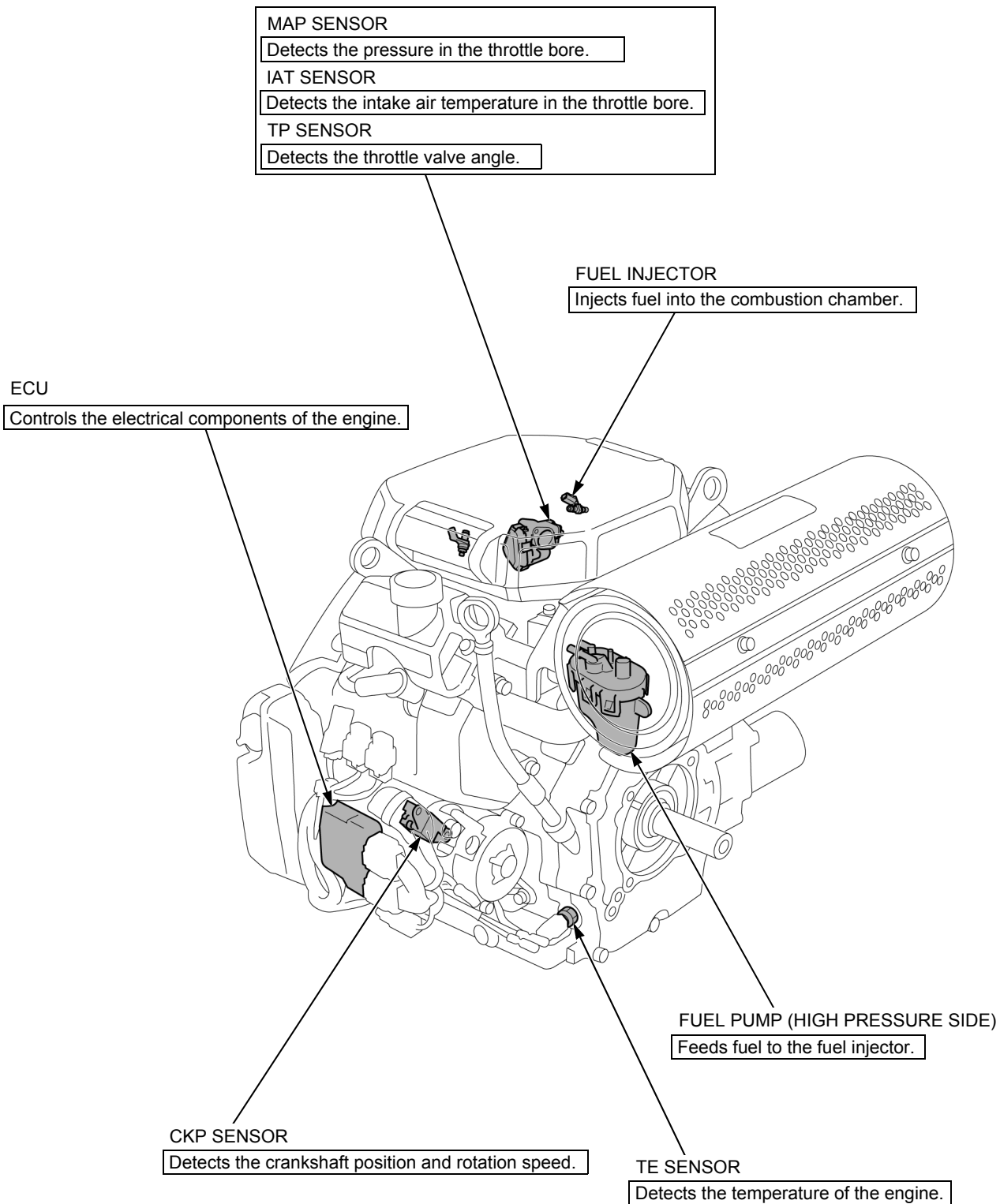

## CAULKING CLAMP

Caulking clamp is not reusable because you need to cut off the caulking portion to remove them.

To apply this type of clamp, use a special crimper tool (OETIKER 1098 or equivalent) and keep the clearance at the base of the caulking portion within the specified limit.

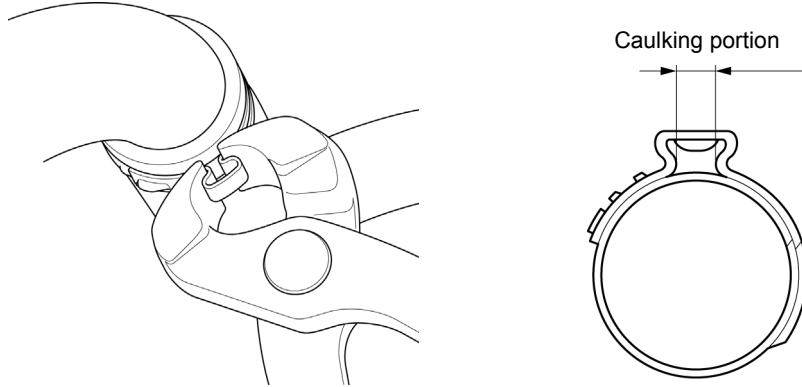

---

**MEMO**

---

# 16. WIRING DIAGRAMS

---

WIRING DIAGRAMS .....16-2



# WIRING DIAGRAMS

## WIRING DIAGRAMS

### CONTROL BOX TYPE

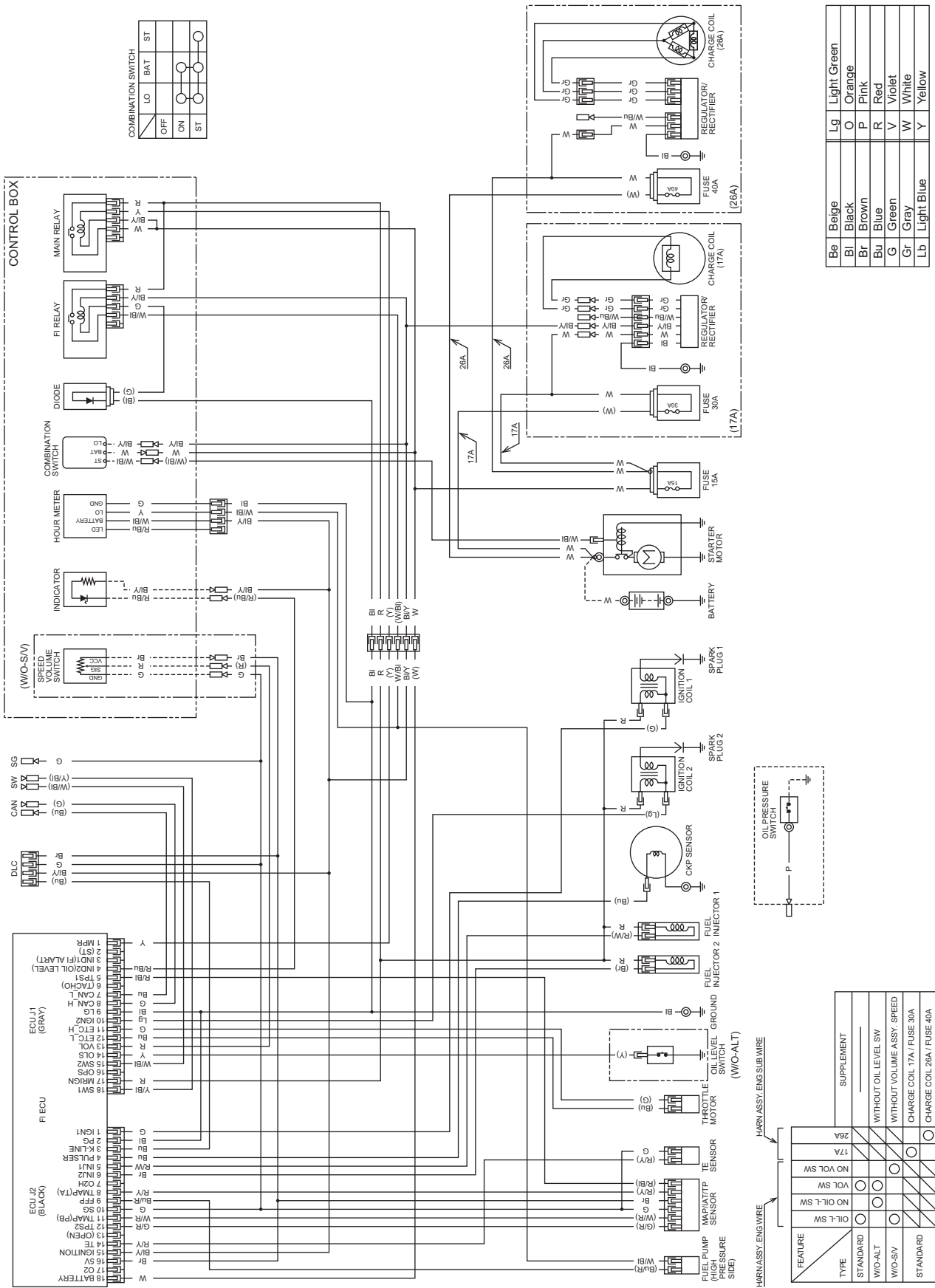

COMBINATION SWITCH	
LO	ST
OFF	ON
ON	ST

Be	Beige	Lg	Light Green
Bl	Black	O	Orange
Br	Brown	P	Pink
Bu	Blue	R	Red
G	Green	V	Violet
Gr	Gray	W	White
Lb	Light Blue	Y	Yellow

FEATURE	TYPE	SUPPLEMENT
FUEL PUMP PRESSURE SENSOR <td>STANDARD</td> <td>NO</td>	STANDARD	NO
MAP/TPP SENSOR <td>W/O-ALT</td> <td>NO</td>	W/O-ALT	NO
THROTTLE MOTOR <td>W/O-ALT</td> <td>NO</td>	W/O-ALT	NO
OIL LEVEL SWITCH <td>W/O-ALT</td> <td>NO</td>	W/O-ALT	NO
FUEL INJECTOR 1 <td>W/O-S/V</td> <td>NO</td>	W/O-S/V	NO
FUEL INJECTOR 2 <td>W/O-S/V</td> <td>NO</td>	W/O-S/V	NO
CRP SENSOR <td>W/O-S/V</td> <td>NO</td>	W/O-S/V	NO
IGNITION COIL 1 <td>W/O-S/V</td> <td>NO</td>	W/O-S/V	NO
IGNITION COIL 2 <td>W/O-S/V</td> <td>NO</td>	W/O-S/V	NO
SPARK PLUG 1 <td>W/O-S/V</td> <td>NO</td>	W/O-S/V	NO
SPARK PLUG 2 <td>W/O-S/V</td> <td>NO</td>	W/O-S/V	NO
BATTERY <td>W/O-S/V</td> <td>NO</td>	W/O-S/V	NO
STARTER MOTOR <td>W/O-S/V</td> <td>NO</td>	W/O-S/V	NO
FUSE 19A <td>W/O-S/V</td> <td>NO</td>	W/O-S/V	NO
FUSE 30A <td>W/O-S/V</td> <td>NO</td>	W/O-S/V	NO
FUSE 40A <td>W/O-S/V</td> <td>NO</td>	W/O-S/V	NO
REGULATOR/RECTIFIER <td>W/O-S/V</td> <td>NO</td>	W/O-S/V	NO
CHARGE COIL (17A) <td>W/O-S/V</td> <td>NO</td>	W/O-S/V	NO
REGULATOR/RECTIFIER <td>W/O-S/V</td> <td>NO</td>	W/O-S/V	NO
CHARGE COIL (26A) <td>W/O-S/V</td> <td>NO</td>	W/O-S/V	NO

REMOTE TYPE

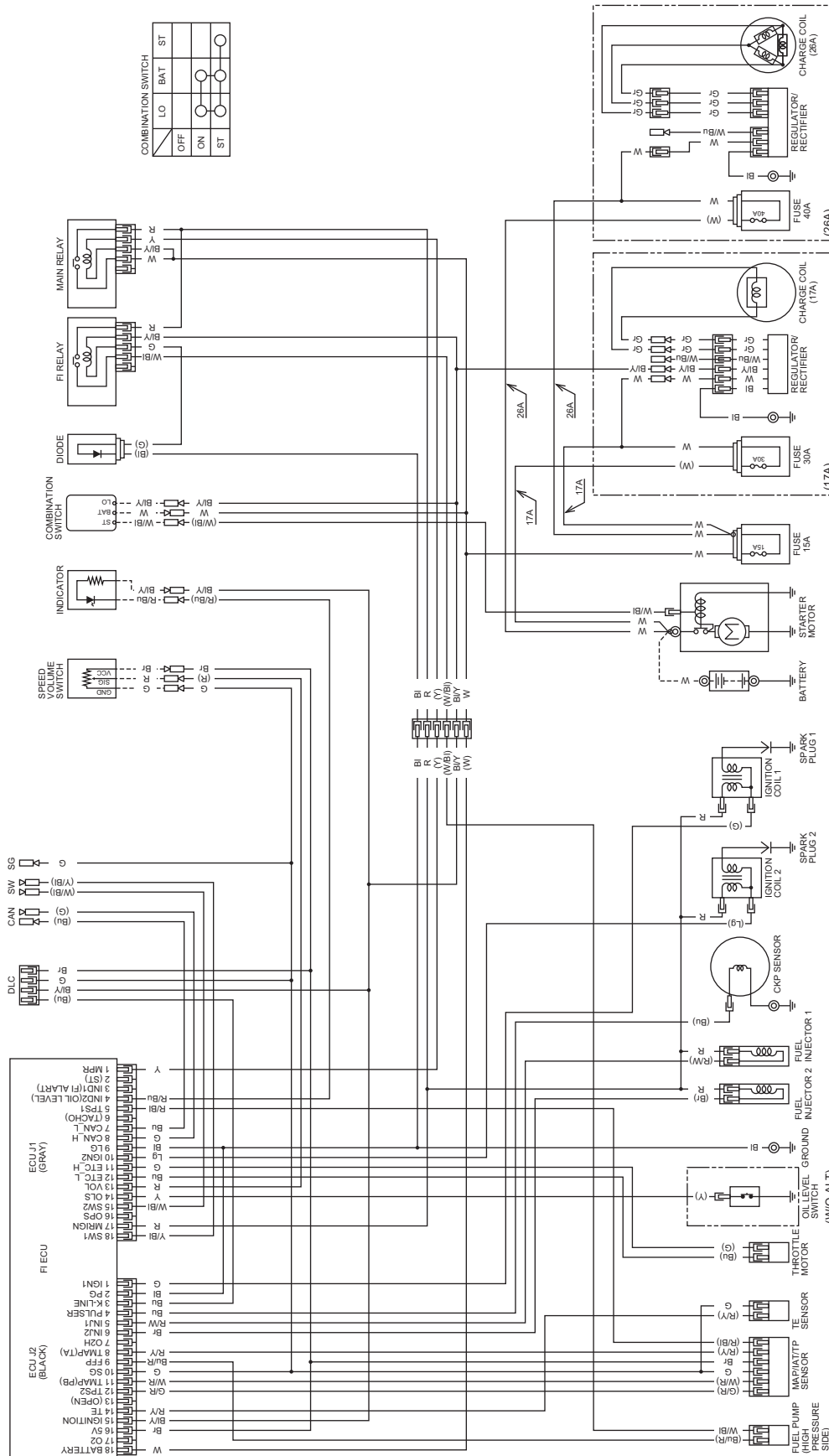

COMBINATION SWITCH

	LO	BAT	ST
OFF			
OK			
ST			

Be	Beige	Lg	Light Green
Bl	Black	O	Orange
Br	Brown	P	Pink
Bu	Blue	R	Red
G	Green	V	Violet
Gr	Gray	W	White
Lb	Light Blue	Y	Yellow

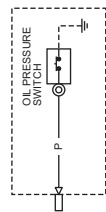

FEATURE	TYPE	SUPPLEMENT
STANDARD	NO OIL-L SW	WITHOUT OIL LEVEL SW
W/O-ALT	OIL-L SW	CHARGE COIL 17A / FUSE 30A
STANDARD		CHARGE COIL 26A / FUSE 40A

HARN ASSY. ENG. WIRE

HARN ASSY. SUB WIRE

---

**MEMO**

---

<b>A</b>		
AIR CLEANER .....	6-12	
AIR CLEANER CHECK/CLEANING .....	3-5	
AIR CLEANER REPLACEMENT .....	3-6	
<b>B</b>		
BEFORE TROUBLESHOOTING .....	4-2	
BREATHER .....	14-5	
<b>C</b>		
CAULKING CLAMP .....	6-15, 15-3	
CHARGE COIL .....	7-7	
CKP SENSOR .....	10-3	
COMBINATION SWITCH INSPECTION .....	10-8	
COMBUSTION CHAMBER CLEANING .....	3-10	
CONTROL BOX .....	10-6	
COOLING FAN/FLYWHEEL .....	7-4	
CRANKCASE COVER .....	14-2	
CRANKCASE COVER/CRANKCASE/CRANKSHAFT/ CONNECTING ROD/CAMSHAFT/VALVE LIFTER INSPECTION .....	14-8	
CRANKCASE STUD BOLT REPLACEMENT .....	14-16	
CRANKSHAFT OIL SEAL REPLACEMENT (CRANKCASE COVER SIDE) .....	14-14	
CRANKSHAFT OIL SEAL REPLACEMENT (CRANKCASE SIDE) .....	14-15	
CRANKSHAFT/CONNECTING ROD/CAMSHAFT/ VALVE LIFTER .....	14-4	
CYLINDER DISASSEMBLY/ASSEMBLY .....	13-5	
CYLINDER INSTALLATION .....	13-3	
CYLINDER/PISTON INSPECTION .....	13-7	
CYLINDER/PISTON REMOVAL .....	13-2	
<b>D</b>		
DIMENSIONAL DRAWINGS .....	1-6	
DIMENSIONS AND WEIGHTS SPECIFICATIONS .....	1-2	
DTC INDEX .....	4-7	
DTC TROUBLESHOOTING .....	4-7	
<b>E</b>		
ECU .....	10-2	
ENGINE MOUNT DIMENSIONAL DRAWING .....	1-10	
ENGINE OIL CHANGE .....	3-4	
ENGINE OIL LEVEL CHECK .....	3-3	
ENGINE SPECIFICATIONS .....	1-3	
<b>F</b>		
FAN COVER .....	5-2	
FUEL FILTER REPLACEMENT .....	3-11	
FUEL INJECTION SYSTEM .....	15-2	
FUEL LINE INSPECTION .....	6-6	
FUEL PUMP (HIGH PRESSURE SIDE) .....	6-14	
FUEL PUMP (LOW PRESSURE SIDE) .....	6-13	
FUEL TUBE CHECK .....	3-11	
FUSE .....	10-3	
<b>H</b>		
HARNESS ROUTING .....	2-12	
HIGH MOUNT MUFFLER .....	11-2	
HOUR METER INSPECTION .....	10-8	
<b>I</b>		
IGNITION COIL .....	8-3	
INDICATOR INSPECTION .....	10-8	
<b>L</b>		
LOWER SHROUD .....	5-3	
LUBRICATION & SEAL POINT .....	2-7	
LUBRICATION SYSTEM DIAGRAM .....	12-2	
<b>M</b>		
MAINTENANCE SCHEDULE .....	3-2	
MAINTENANCE STANDARDS .....	2-2	
<b>O</b>		
OIL COOLER (GX800 ONLY) .....	12-6	
OIL FILTER REPLACEMENT .....	3-4	
OIL LEVEL SWITCH .....	10-5	
OIL PRESSURE SWITCH .....	12-3	
OIL PRESSURE TEST .....	12-4	
OIL PUMP INSPECTION .....	12-5	
OIL PUMP/OIL FILTER .....	14-7	
<b>P</b>		
P.T.O. DIMENSIONAL DRAWINGS .....	1-8	
PERFORMANCE CURVES .....	1-4	
PISTON DISASSEMBLY/ASSEMBLY .....	13-6	
PISTON INSTALLATION .....	13-3	
<b>R</b>		
REGULATOR/RECTIFIER .....	7-8	
RELAY .....	10-2	
RESISTOR INSPECTION .....	10-9	
<b>S</b>		
SERIAL NUMBER LOCATION .....	1-2	
SPARK ARRESTER CLEANING .....	3-8	
SPARK PLUG CHECK/ADJUSTMENT .....	3-6	
SPARK PLUG REPLACEMENT .....	3-7	
SPARK TEST .....	8-4	
SPEED VOLUME SWITCH INSPECTION .....	10-9	
STARTER MOTOR .....	9-4	
STUD BOLT REPLACEMENT .....	11-3	
SYSTEM DIAGRAM		
CHARGING SYSTEM .....	7-2	
FUEL SYSTEM .....	6-2	
IGNITION SYSTEM .....	8-2	
STARTING SYSTEM .....	9-2	
<b>T</b>		
TE SENSOR .....	10-4	
THROTTLE BODY/INLET MANIFOLD/ FUEL INJECTOR .....	6-16	
TOOLS .....	2-8	
TORQUE VALUES .....	2-5	
TROUBLESHOOTING		
CHARGING SYSTEM .....	7-3	
FUEL SYSTEM .....	6-3	
IGNITION SYSTEM .....	8-2	
STARTING SYSTEM .....	9-3	
TROUBLESHOOTING .....	4-3	
TUBE ROUTING .....	2-19	
<b>V</b>		
VALVE CLEARANCE CHECK/ADJUSTMENT .....	3-8	
VALVE LIFTER .....	14-8	
VALVE SEAT RECONDITIONING .....	13-14	
<b>W</b>		
WIRING DIAGRAMS .....	16-2	

